

Transmittal, reproduction, dissemination and/or editing of this document as well as utilization of its contents and communication thereof to others without express authorization are prohibited.
 未经允许禁止传输、复制、编辑该文档，以及利用其内容进行交流

REVISION RECORD				
REV	ECN	DESCRIPTION	DRFT	DATE

订货号		线径/Wire gauge		A	B	C
表面镀银 Silver-plated	表面镀金 Gold-plated	(mm ²)	(AWG)			
SCSM-010-0.37	SCGM-010-0.37	0.14-0.37	26-22	2.6	0.90	8mm
SCSM-010-0.5	SCGM-010-0.5	0.50	20	2.6	1.10	8mm
SCSM-010-0.75	SCGM-010-0.75	0.75	18	2.6	1.30	8mm
SCSM-010-1.0	SCGM-010-1	1.00	18	2.6	1.45	8mm
SCSM-010-1.5	SCGM-010-1.5	1.50	16	3.0	1.75	8mm
SCSM-010-2.5	SCGM-010-2.5	2.50	14	3.2	2.25	6mm

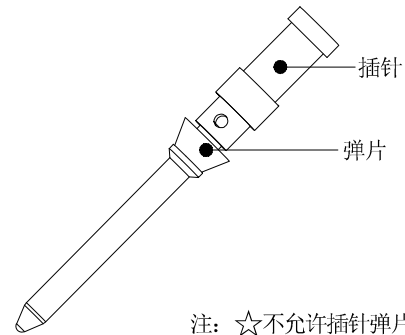
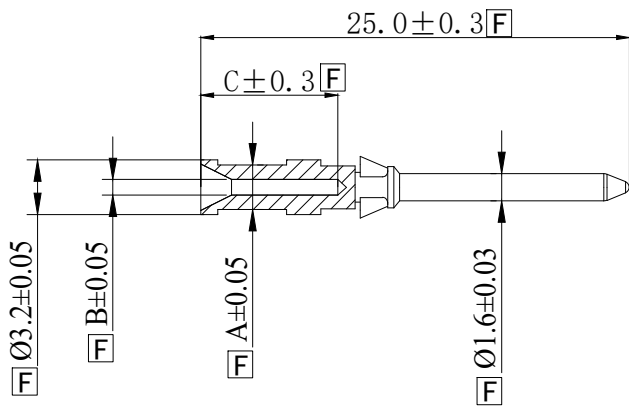

注：☆不允许插针弹片弹片脱落或漏装弹片

借通用件登记
Common Part

原图号
Old Draw. No.

底图总号
Assembly No.

技术要求:

1. 表面不能有碰伤、划伤等不良现象,允许最大毛刺量0.05mm;
2. 零件外观镀层不能有脏污、起泡、露铜和脱落等不良现象;
3. 需符合RoHS 2.0环保要求;
4. “**F**”为重点管控尺寸;
5. 未标注公差按如下公差表;

尺寸公差(mm)							- 0.1/10	∩ /	∇ /
0 ~ ≤20	20 ~ ≤50	50 ~ ≤80	80 ~ ≤120	120 ~ ≤150	150 ~ ≤200	>200			
±0.15	±0.25	±0.35	±0.50	±0.70	±1.00	±1.50	±1.5°		

订货号 Order No.	SC(S/G)M-010-X		名称 Name	10A-公插针	未注公差 Tolerance	表面 Surface	
项目 Item	签字 Signature	日期 Date			见未注公差表	/	
设计 Design	史文莉	03/03/22"	图号 Drawing No.	SP7412Z9001	版本号 Revision Number	重量 Weight	比例 Scale
审核 Check	毛海林	03/03/22"	材料 Material	/	01	/	1:1
工艺 Process	/	/	物料号 Item No.	/	第1页/共1页 1 of 1	⊕ ⊖ mm	
标准化 Unify	/	/		/	SUPU 宁波盛普电子有限公司		
批准 Approve	梁文龙	03/03/22"		/	NINGBO SUPU ELECTRONICS CO.,LTD.		