

Transmittal, reproduction, dissemination and/or editing of this document as well as utilization of its contents and communication thereof to others without express authorization are prohibited.  
未经允许禁止传输、复制、编辑该文档，以及利用其内容进行交流

REVISION RECORD

REV	CN	DESCRIPTION	DRFT	DATE

General information:

1. Material: Aluminium die-cast
2. Colour: Grey
3. Surface: Powder-coated
4. Operating temperature: -40°C~+125°C
5. Degree of protection acc.to DIN EN60529 for coupled connector: IP65
6. Outgoing direction: Side entry
7. Locking element:  
Locking type: Double locking latch  
Material: metal galvanized/nickel plating
8. Thread size: M/PG
9. Hoods&Housings seal: NBR
10. Undimensioned Tolerances:

Pitch	Range in mm	Nominal Dimension	Range in mm	-	+/-
Over 6 TO 6	Over 10 TO 24	Over 30 TO 60	Over 60 TO 100	Over 100 TO 150	0.1/0
±0.15	±0.20	±0.30	±0.50	±0.70	±1.00
					±2'

HOW TO ORDER:

S32A-BM-2L.M

- Locking lever — 1L: 1 levers(plastic) 2B: 2 bolts  
2L: 2 levers(plastic) 4B: 4 bolts  
1L.M: 1 levers(Metal) 2L.M: 2 levers(Metal)
- Housing type — SE: Side entry  
SEH: Side entry-high construction  
TE: Top entry  
TEH: Top entry-high construction  
BM: Bulkhead mounted  
SM: Sufeace mounted  
SMH: Sufeace mounted-high construction  
CC: Cable to cable  
CCH: Cable to cable high construction
- Series — S3A: 3A Compact type S6B: 6B Standard type  
S10A: 10A Compact type S10B: 10B Standard type  
S16A: 16A Compact type S16B: 16B Standard type  
S24B: S24B Standard type S32B: S32B Standard type  
S48B: S48B Standard type

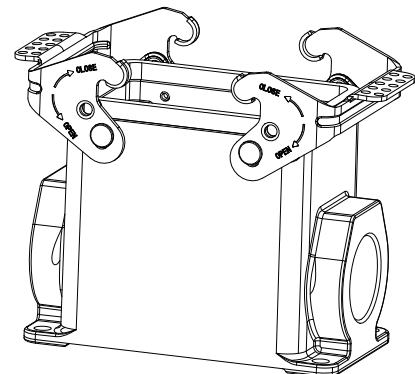
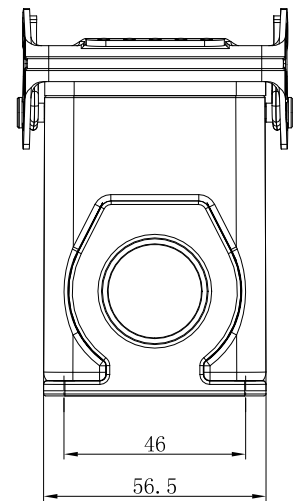
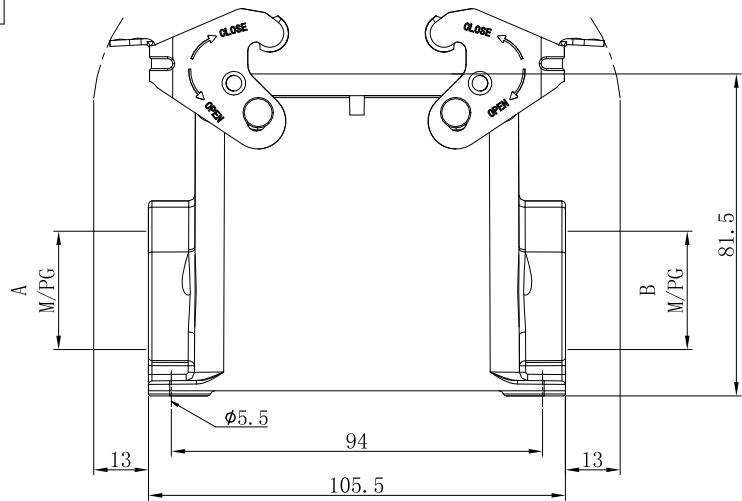

Order number	A	B
S32A-SM-2L.M-M25	M25×1.5	
S32A-SM-2L.M-M32	M32×1.5	/
S32A-SM-2L.M-2M32	M32×1.5	M32×1.5
S32A-SM-2L.M-PG21	PG21	/
S32A-SM-2L.M-2PG21	PG21	PG21
S32A-SM-2L.M-PG29	PG29	/
S32A-SM-2L.M-2PG29	PG29	PG29

借通用件登记  
Common Part

原图号  
Old Draw. No.

底图总号  
Assembly No.

订货号 Order No.	S32A-SM-2L.M-XXX		名称 Name	S32A表面安装 金属双扣底座-XXX	未注公差 Tolerance	表面 Surface	
项目 Item	签字 Signature	日期 Date	图号 Drawing No.	/	Tolerances Table		VDI21
设计 Design	CHH	2024.07.11	材料 Material	/	版本号 Revision Number	重量 Weight	比例 Scale
审核 Check	CHH	2024.07.11	物料号 Item No.	/	MO	/	1:1
工艺 Process	-	-		/	第1页/共1页 1 of 1	mm	
标准化 Unify	-	-		/	宁波盛普电子有限公司 NINGBO SUPU ELECTRONICS CO.,LTD.		
批准 Approve	XJ	2024.07.11		/			