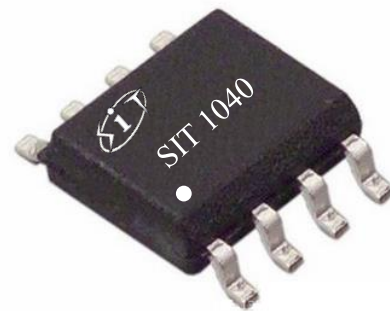

**FEATURES**

- Fully compatible with the ISO 11898 standard
- Thermally protected
- Input levels compatible with 3.3 V and 5 V devices
- Transmit Data (TXD) dominant time-out function
- Very low-current standby mode with remote wake-up Capability via the bus: 5μA Typical
- Transceiver in unpowered state disengages from the bus (zero load)
- At least 110 nodes can be connected
- High speed (up to 1 MBaud)
- Very low Electro Magnetic Emission (EME)

**OUTLINE**

Provide Green and Environmentally Friendly Lead-free package

\*Provide HVSON8 / DFN3\*3-8,

Small Outline, Leadless Package

**DESCRIPTION**

The SIT1040 is the interface between the Controller Area Network (CAN) protocol controller and the physical bus. It is primarily intended for high speed applications, up to 1 MBaud, in passenger cars. The device provides differential transmit capability to the bus and differential receive capability to the CAN controller.

PARAMETER	SYMBOL	CONDITION	MIN.	MAX.	UNIT
Supply voltage	$V_{cc}$		4.5	5.5	V
Maximum transmission rate	$1/t_{bit}$	Non-return to zero code	1		Mbaud
CANH/CANL input or output voltage	$V_{can}$		-40	+40	V
Bus differential voltage	$V_{diff}$		1.5	3.0	V
Virtual junction temperature	$T_{amb}$		-40	125	°C

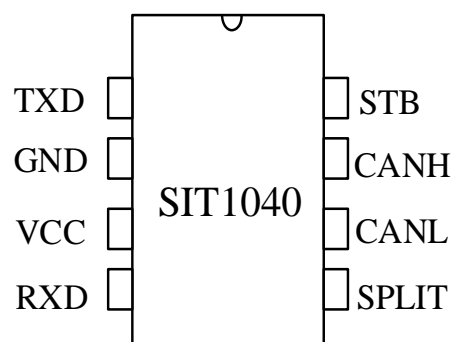
**PIN CONFIGURATION**

**LIMITING VALUES**

PARAMETER	SYMBOL	VALUE	UNIT
Supply voltage	$V_{CC}$	-0.3~+6	V
DC voltage on TXD/RXD/STB pins	TXD, RXD, STB	-0.3~ $V_{CC}+0.3$	V
Voltage range at any bus terminal (CANH, CANL, SPLIT)	CANL, CANH, SPLIT	-40~40	V
Transient voltage on pins CANH, CANL and SPLIT see Fig.7	$V_{tr}$	-200~+200	V
Storage temperature		-55~150	°C
Virtual junction temperature		-40~125	°C
Welding temperature range		300	°C

The maximum limit parameters means that exceeding these values may cause irreversible damage to the device. Under these conditions, it is not conducive to the normal operation of the device. The continuous operation of the device at the maximum allowable rating may affect the reliability of the device. The reference point for all voltages is ground.

**PINNING**

PIN	SYMBOL	DESCRIPTION
1	TXD	transmit data input
2	GND	ground supply
3	VCC	supply voltage
4	RXD	receive data output; reads out data from the bus lines
5	SPLIT	common-mode stabilization output
6	CANL	LOW-level CAN bus line
7	CANH	HIGH-level CAN bus line
8	STB	standby mode control input

**DRIVER ELECTRICAL CHARACTERISTICS**

PARAMETER	SYMBOL	CONDITION	MIN.	TYP.	MAX.	UNIT
CANH dominant output voltage	$V_{OH(D)}$	VI=0V, STB=0V, RL=60Ω, Fig.1, Fig.2	2.9	3.4	4.5	
CANL dominant output voltage	$V_{OL(D)}$		0.8		1.5	
Bus recessive output voltage	$V_{O(R)}$	VI=3V, STB=0V, RL=60Ω, Fig.1, Fig.2	2	2.5	3	V
Bus dominant differential output voltage	$V_{OD(D)}$	VI=0V, STB=0V, RL=60Ω, Fig.1, Fig.2	1.5		3	V
Bus recessive differential output voltage	$V_{OD(R)}$	VI=3V, S=0V, Fig.1, Fig.2	-0.012		0.012	V
		VI=3V, STB=0V, NO LOAD	-0.5		0.05	V
Transmitter dominant voltage symmetry	$V_{dom(TX)sym}$	$V_{dom(TX)sym}=V_{CC}-V_{CANH}-V_{CANL}$	-400		400	mV
Transmitter voltage symmetry	$V_{TXsym}$	$V_{TXsym}=V_{CANH}+V_{CANL}$	$0.9V_{CC}$		$1.1V_{CC}$	V
Common-mode output voltage	$V_{OC}$	STB=0V, Fig.8	2	2.5	3	V
Peak-to-peak Common-mode output voltage	$\Delta V_{OC}$			30		mV
Short-circuit output current	$I_{OS}$	CANH=-12V, CANL=open, Fig.11	-105	-72		mA
		CANH=12V, CANL=open, Fig.11		0.36	1	
		CANL=-12V, CANH=open, Fig.11	-1	0.5		
		CANL=12V, CANH=open, Fig.11		71	105	
Recessive output current	$I_{O(R)}$	-27V<CANH<32V 0<VCC<5.25V	-2.0		2.5	mA

( $V_{CC}=5V \pm 10\%$  and  $Temp=T_{MIN} \sim T_{MAX}$  unless specified otherwise; typical in  $V_{CC}=+5V$  and  $Temp=25^{\circ}C$ )

**DRIVER SWITCHING CHARACTERISTICS**

PARAMETER	SYMBOL	CONDITION	MIN.	TYP.	MAX.	UNIT
Propagation delay time, low-to-high-level output	tPLH	STB=0V, Fig.4	25	65	120	ns
Propagation delay time, low-to-high-level output	tPHL		25	45	90	ns
Differential output signal rise time	tr			25		ns
Differential output signal fall time	tf			50		ns
Enable time from standby mode to dominant	t <sub>EN</sub>	Fig.7			10	μs
Bus dominant time-out time	t <sub>dom</sub>	Fig.10	300	450	700	μs
Bus wake-up filter time	t <sub>BUS</sub>		0.7		5	μs

(V<sub>CC</sub>=5V ±10% and Temp=T<sub>MIN</sub>~T<sub>MAX</sub> unless specified otherwise; typical in V<sub>CC</sub>=+5V and Temp=25°C)

**RECEIVER ELECTRICAL CHARACTERISTICS**

PARAMETER	SYMBOL	CONDITION	MIN.	TYP.	MAX.	UNIT
Positive-going input threshold voltage	V <sub>IT+</sub>	STB=0V, Fig.5		800	900	mV
Negative-going input threshold voltage	V <sub>IT-</sub>		500	650		
Hysteresis voltage (V <sub>IT+</sub> – V <sub>IT-</sub> )	V <sub>HYS</sub>		100	125		
High-level output voltage	V <sub>OH</sub>	IO=-2mA, Fig.6	4	4.6		V
Low-level output voltage	V <sub>OL</sub>	IO=2mA, Fig.6		0.2	0.4	V
Power-off bus input current	I <sub>(OFF)</sub>	CANH or CANL=5V, Other pin=0V			5	μA
Input capacitance to	C <sub>I</sub>			13		pF

ground, (CANH or CANL)						
Differential input capacitance	$C_{ID}$			5		pF
Input resistance, (CANH or CANL)	$R_{IN}$	TXD=3V, STB=0V	15	30	40	K $\Omega$
Differential input resistance	$R_{ID}$		30		80	K $\Omega$
Input resistance matching	$R_{I_{match}}$	CANH=CANL	-3%		3%	
The range of common-mode voltage	$V_{COM}$		-12		12	V

( $V_{CC}=5V \pm 10\%$  and  $Temp=T_{MIN} \sim T_{MAX}$  unless specified otherwise; typical in  $V_{CC}=+5V$  and  $Temp=25^{\circ}C$ )

### RECEIVER SWITCHING CHARACTERISTICS

PARAMETER	SYMBOL	CONDITION	MIN.	TYP.	MAX.	UNIT
Propagation delay time, low-to-high-level output	tPLH	STB=0V or VCC, Fig.6	60	100	130	ns
Propagation delay time, low-to-high-level output	tPHL		45	70	90	ns
RXD signal rise time	tr			8		ns
RXD signal fall time	tf			8		ns

( $V_{CC}=5V \pm 10\%$  and  $Temp=T_{MIN} \sim T_{MAX}$  unless specified otherwise; typical in  $V_{CC}=+5V$  and  $Temp=25^{\circ}C$ )

### DEVICE SWITCHING CHARACTERISTICS

PARAMETER	SYMBOL	CONDITION	MIN.	TYP.	MAX.	UNIT
Loop delay 1, driver input to receiver output, Recessive to Dominant	Td(LOOP1)	STB=0V, Fig.9	90		190	ns
Loop delay 2, driver input to receiver output, Dominant to Recessive	Td(LOOP2)		90		190	ns

( $V_{CC}=5V \pm 10\%$  and  $Temp=T_{MIN} \sim T_{MAX}$  unless specified otherwise; typical in  $V_{CC}=+5V$  and  $Temp=25^{\circ}C$ )

**OVER TEMPERATURE PROTECTION**

PARAMETER	SYMBOL	CONDITION	MIN.	TYP.	MAX.	UNIT
Shutdown junction temperature	Tj(sd)			160		°C

**TXD-PIN CHARACTERISTICS**

PARAMETER	SYMBOL	CONDITION	MIN.	TYP.	MAX.	UNIT
HIGH-level input current	I <sub>IH</sub> (TXD)	V <sub>I</sub> =V <sub>CC</sub>	-2		2	μA
LOW-level input current	I <sub>IL</sub> (TXD)	V <sub>I</sub> =0	-50		-10	μA
When V <sub>CC</sub> =0V, current on TXD pin	I <sub>O</sub> (off)	V <sub>CC</sub> =0V, TXD=5V			1	μA
HIGH-level input voltage	V <sub>IH</sub>		2		V <sub>CC</sub> +0.3	V
LOW-level input voltage	V <sub>IL</sub>		-0.3		0.8	V
Open voltage on TXD pin	TXD <sub>O</sub>		H			logic

(V<sub>CC</sub>=5V±10% and Temp=T<sub>MIN</sub>~T<sub>MAX</sub> unless specified otherwise; typical in V<sub>CC</sub>=+5V and Temp=25°C)

**COMMON-MODE STABILIZATION OUTPUT**

PARAMETER	SYMBOL	CONDITION	MIN.	TYP.	MAX.	UNIT
Common-mode stabilization output voltage	V <sub>O</sub>	-500uA<I <sub>o</sub> <500uA	0.3V <sub>CC</sub>		0.7V <sub>CC</sub>	V
Leakage current	I <sub>O</sub> (stb)	STB=2, -12V<V <sub>O</sub> <12V	-5		5	μA

(V<sub>CC</sub>=5V±10% and Temp=T<sub>MIN</sub>~T<sub>MAX</sub> unless specified otherwise; typical in V<sub>CC</sub>=+5V and Temp=25°C)



## SUPPLY CURRENT

PARAMETER	SYMBOL	CONDITION	MIN.	TYP.	MAX.	UNIT
Standby	$I_{CC}$	STB=VCC, $V_I=V_{CC}$		5	12	$\mu A$
Dominant		$V_I=0V$ , STB=0V, LOAD=60 $\Omega$		50	70	mA
Recessive		$V_I=V_{CC}$ , STB=0V, NO LOAD		6	10	mA

( $V_{CC}=5V \pm 10\%$  and  $Temp=T_{MIN} \sim T_{MAX}$  unless specified otherwise; typical in  $V_{CC}=+5V$  and  $Temp=25^\circ C$ )

## FUNCTION TABLE

Table1.CAN TRANSCEIVER TRUTH TABLE

$V_{CC}$	TXD <sup>(1)</sup>	STB <sup>(1)</sup>	CANH <sup>(1)</sup>	CANL <sup>(1)</sup>	BUS STATE	RXD <sup>(1)</sup>
4.5V~5.5V	L	L	H	L	Dominate	L
4.5V~5.5V	H or Open	X <sup>(1)</sup>	0.5 $V_{CC}$	0.5 $V_{CC}$	Recessive	H
4.5V~5.5V	X	H or Open	0.5 $V_{CC}$	0.5 $V_{CC}$	Recessive	H
0< $V_{CC}$ <4.5V	X	X	0V< $V_{CANH}$ < $V_{CC}$	0V< $V_{CANL}$ < $V_{CC}$	Recessive	X

(1) H=high level; L=low level; X=irrelevant

Table 2. DRIVER FUNCTION TABLE

INPUTS		OUTPUTS		Bus State
TXD <sup>(1)</sup>	STB <sup>(1)</sup>	CANH <sup>(1)</sup>	CAL <sup>(1)</sup>	
L	L	H	L	Dominate
H or Open	X	Z	Z	Recessive
X	H or Open	Z	Z	Recessive

(1) H=high level; L=low level; X=irrelevant; Z=high impedance

Table 3. RECEIVER FUNCTION TABLE

$V_{ID}=CANH-CANL$	RXD <sup>(1)</sup>	Bus State <sup>(1)</sup>
$V_{ID} \geq 0.9V$	L	Dominate
$0.5 < V_{ID} < 0.9V$	?	?
$V_{ID} \leq 0.5V$	H	Recessive
Open	H	Recessive

(1) H=high-level; L=low-level; ?=uncertain

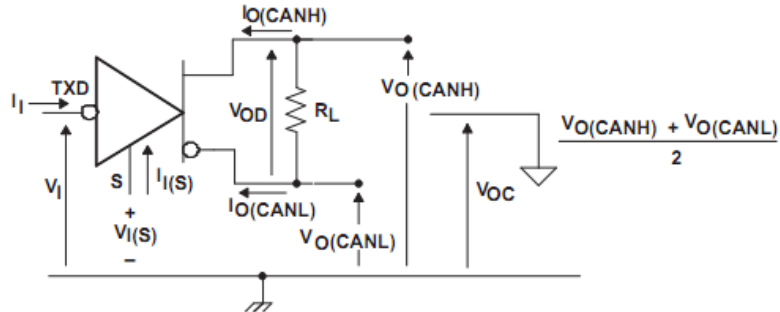
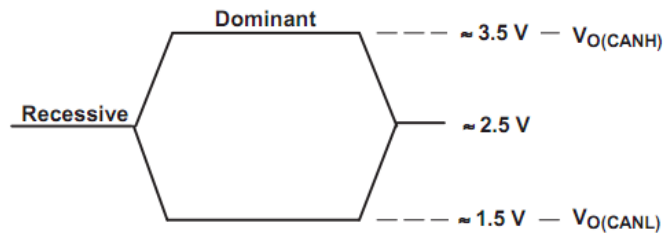
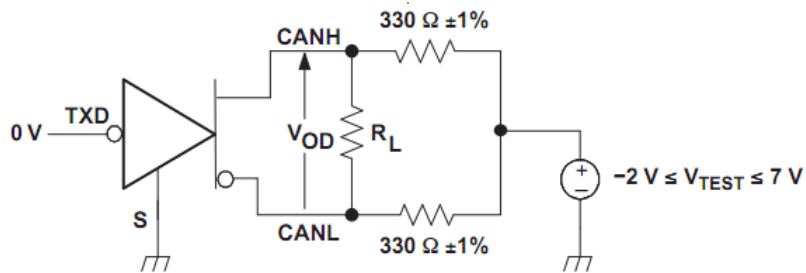
**TEST CIRCUIT**

**Fig.1 Driver Voltage, Current, and Test Definition**

**Fig.2 Bus Logic State Voltage Definition**

**Fig.3 Driver V<sub>OD</sub> Test Circuit**



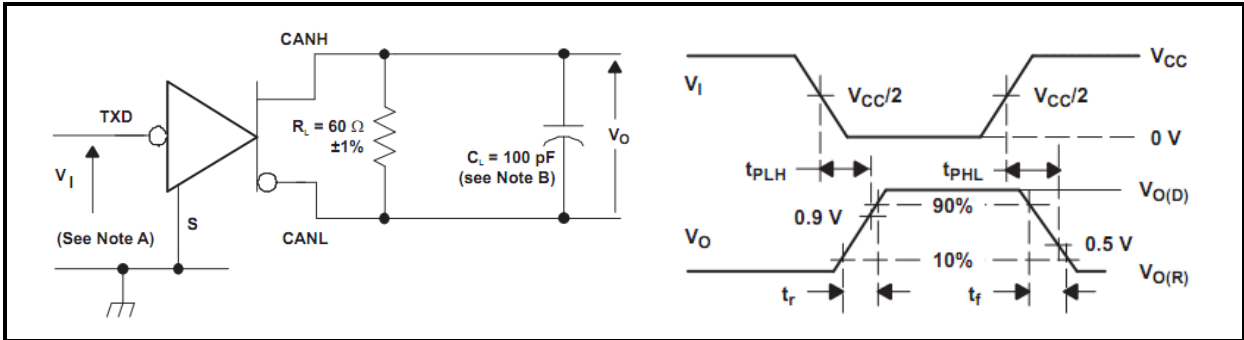

Fig.4 Driver Test Circuit and Waveform

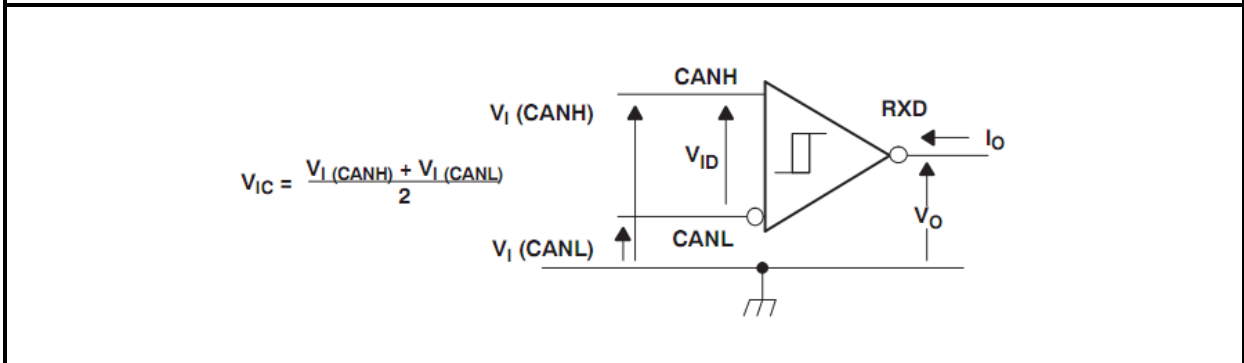
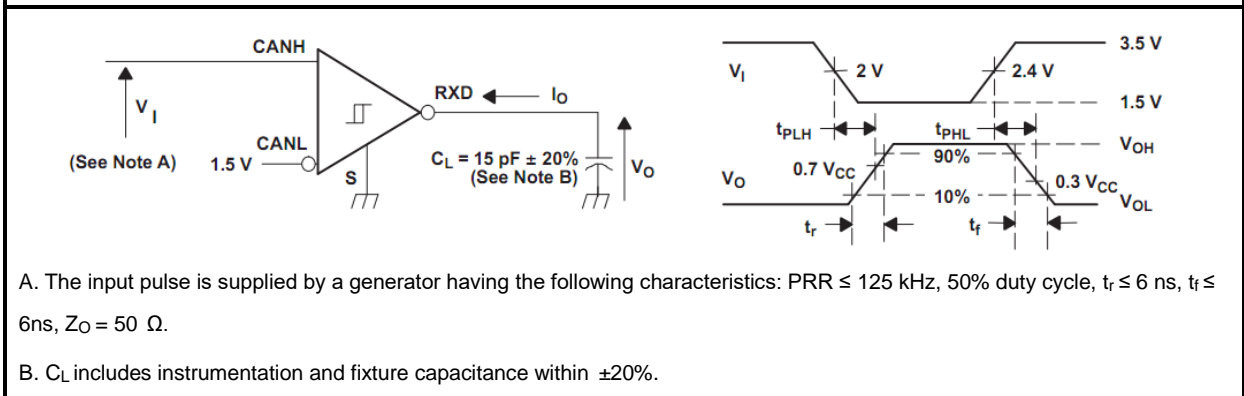

Fig.5 Receiver Voltage and Current Definition



- A. The input pulse is supplied by a generator having the following characteristics: PRR ≤ 125 kHz, 50% duty cycle, t<sub>r</sub> ≤ 6 ns, t<sub>f</sub> ≤ 6 ns, Z<sub>O</sub> = 50 Ω.
- B. C<sub>L</sub> includes instrumentation and fixture capacitance within ±20%.

Fig.6 Receiver Test Circuit and Waveform

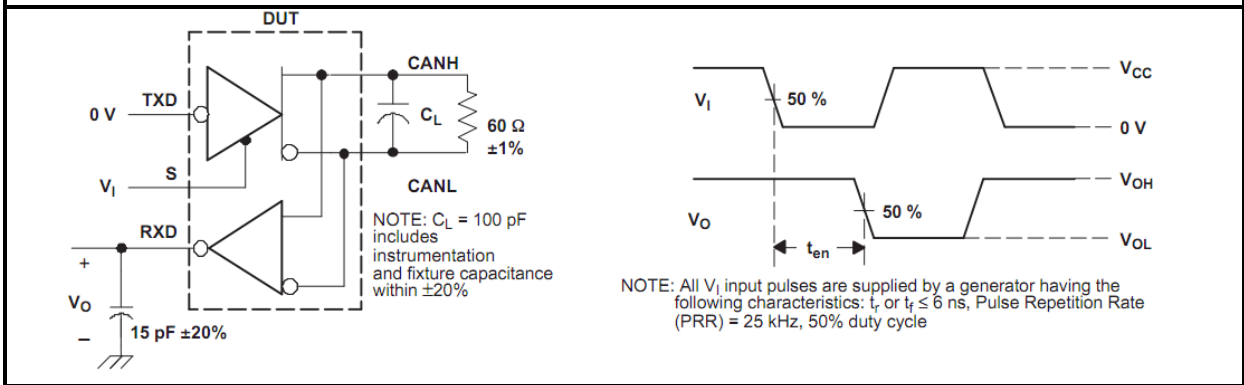
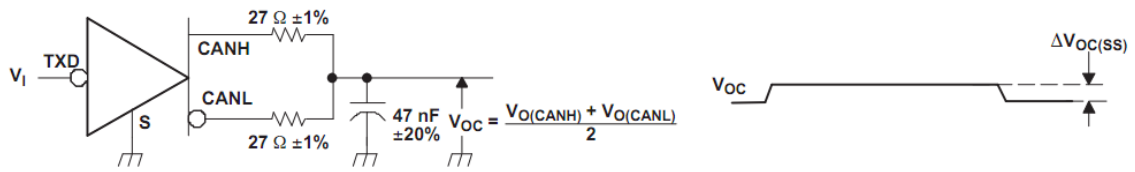

Fig.7 t<sub>EN</sub> Test Circuit and Waveform



A. All V<sub>I</sub> input pulses are from 0 V to V<sub>CC</sub> and supplied by a generator having the following characteristics: t<sub>r</sub> or t<sub>f</sub> ≤ 6 ns. Pulse Repetition Rate (PRR) = 125 kHz, 50% duty cycle.

Fig.8 Peak-to-Peak Common Mode Output Voltage Test and Waveform

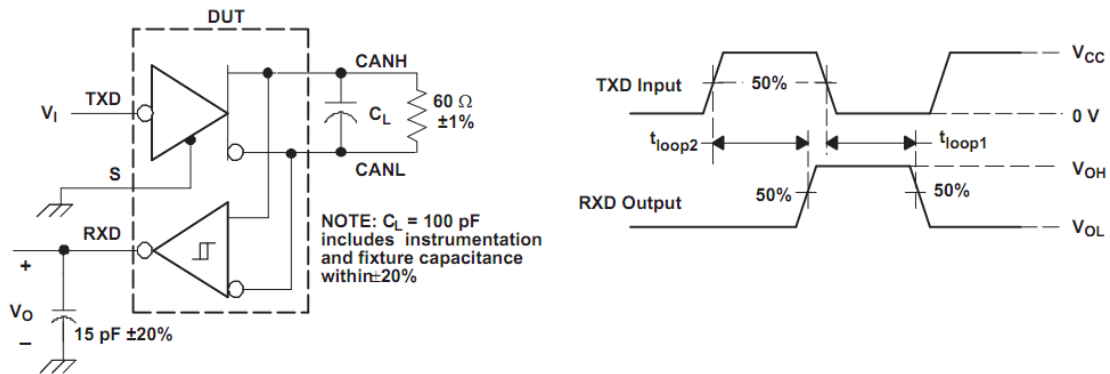

Fig.9 t<sub>(LOOP)</sub> Test Circuit and Waveform

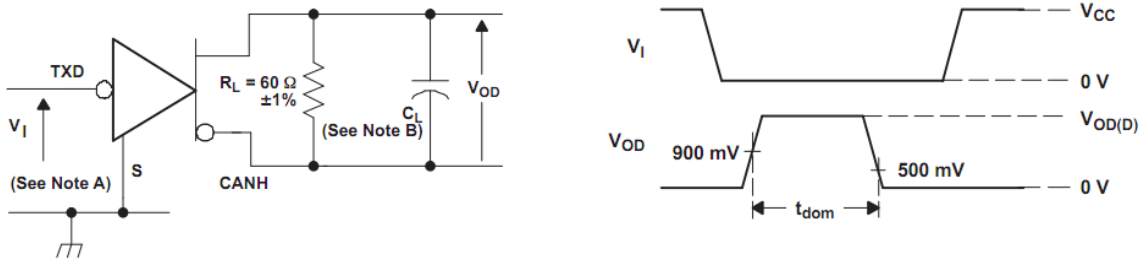

Fig.10 Dominant Time-Out Test Circuit and Waveform

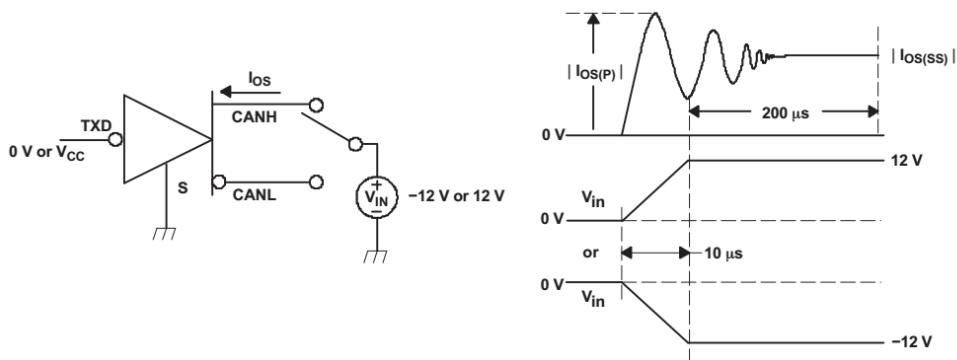

Fig.11 Driver Short-Circuit Current Test Circuit and Waveform

## ADDITIONAL DESCRIPTION

### 1 Sketch

The SIT1040 is the interface between the Controller Area Network (CAN) protocol controller and the physical bus, and can be applied to the fields of trucks, buses, cars, industrial control etc. It is primarily intended for high speed applications, up to 1 MBaud, in passenger cars. The device provides differential transmit capability to the bus and differential receive capability to the CAN controller, and fully compatible with the ISO 11898 standard.

### 2 Current protection

A current-limiting circuit protects the transmitter output stage from damage caused by accidental short-circuit to either positive or negative supply voltage, although power dissipation increases during this fault condition.

### 3 Fail-safe features

Pin TXD provides a pull-up towards VCC in order to force a recessive level in case pin TXD is unpowered. Pin STB provides a pull-up towards VCC in order to force the transceiver into standby mode in case pin STB is unpowered.

In the event that the VCC is lost, pins TXD, STB and RXD will become floating to prevent reverse supplying conditions via these pins.

### 4 Over temperature protection

The output drivers are protected against over-temperature conditions. If the virtual junction temperature exceeds the shutdown junction temperature  $T_{j(sd)}$ , the output drivers will be disabled until the virtual junction temperature becomes lower than  $T_{j(sd)}$  and TXD becomes recessive again.

By including the TXD condition, the occurrence of output driver oscillation due to temperature drifts is avoided.

### 5 TXD dominant time-out function

A 'TXD dominant time-out' timer circuit prevents the bus lines from being driven to a permanent dominant state (blocking all network communication) if pin TXD is forced permanently LOW by a hardware and/or software application failure. The timer is triggered by a negative edge on pin TXD.

If the duration of the LOW level on pin TXD exceeds the internal timer value ( $t_{dom}$ ), the transmitter is disabled, driving the bus lines into a recessive state. The timer is reset by a positive edge on pin TXD.

### 6 Operating modes

The SIT1040 provides two modes of operation which are selectable via pin STB:

High-speed mode and standby mode.

High-speed mode is normal working mode, by connecting STB to ground to set the SIT1040 to high-speed mode. In this mode the transceiver is able to transmit and receive data via the bus lines CANH and CANL.

The differential receiver converts the analog data on the bus lines into digital data which is output to pin RXD via the multiplexer (MUX).



If a logic-high or open is applied to STB, the SIT1040 enters a low-current standby mode. In this mode the transmitter and receiver are switched off, and the low-power differential receiver will monitor the bus lines. A HIGH level on pin STB activates this low-power receiver and the wake-up filter, and after tBUS the state of the CAN bus is reflected on pin RXD.

SOP8 DIMENSIONS

PACKAGE SIZE

SYMBOL	MIN./mm	TYP./mm	MAX./mm
A	1.50	1.60	1.70
A1	0.1	0.15	0.2
A2	1.35	1.45	1.55
b	0.355	0.400	0.455
D	4.800	4.900	5.00
E	3.780	3.880	3.980
E1	5.800	6.000	6.200
e		1.270BSC	
L	0.40	0.60	0.80
c	0.153	0.203	0.253
θ	-2°	-4°	-6°

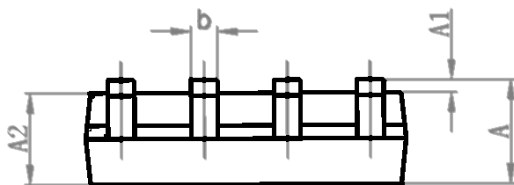
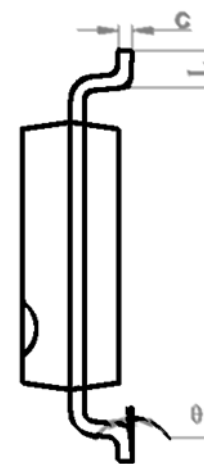
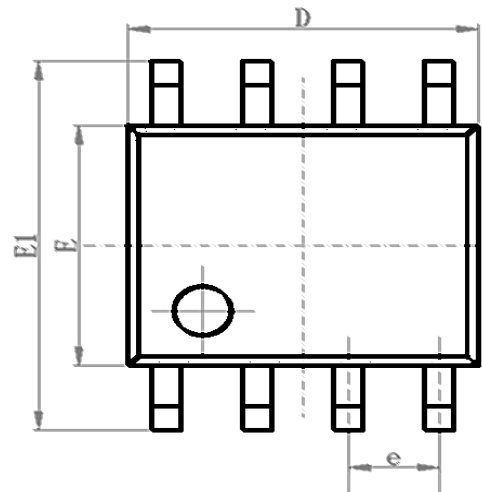



## DFN3\*3-8 /HVSON8 DIMENSIONS

## PACKAGE SIZE

SYMBOL	MIN/mm	TYP /mm	MAX/mm
A	0.700		0.900
A1	0.000	0.02	0.050
A3	0.203 REF		
D	2.900	3.000	3.100
E	2.900	3.000	3.100
D1	1.400	1.5	1.600
E1	2.200	2.3	2.400
k	0.275 REF		
b	0.2	0.25	0.33
e	0.650 TYP		
L	0.250		0.575

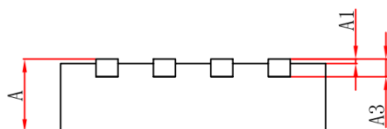
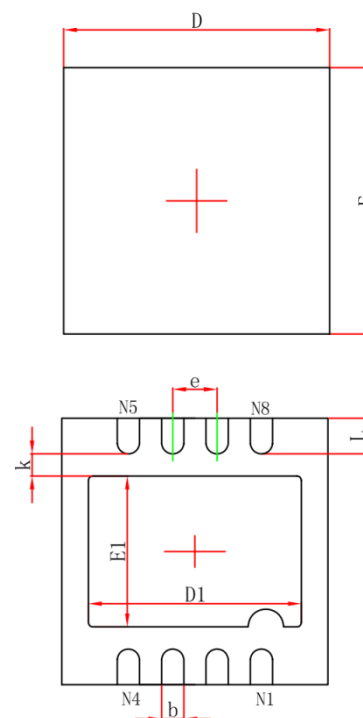

## ORDERING INFORMATION

TYPE NUMBER	TEMPERATURE	PACKAGE
SIT1040T	-40°C~125°C	8 SO
SIT1040TK	-40°C~125°C	HVSON8 / DFN3*3-8, Small Outline, Leadless

Tapered package is 2500 pieces/disc.