

0.5 AMP POSITIVE ADJUSTABLE VOLTAGE REGULATOR IN CERAMIC SURFACE MOUNT PACKAGE

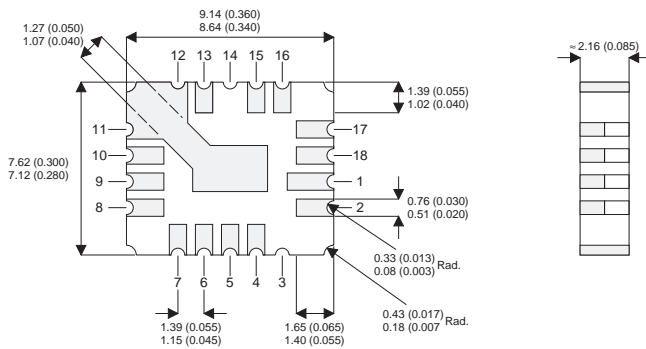

FEATURES

- **OUTPUT VOLTAGE RANGE ADJUSTABLE:**
1.25 TO 40V FOR STANDARD VERSION
1.25 TO 60V FOR –HV VERSION
- **1% OUTPUT VOLTAGE TOLERANCE (–A VERSIONS)**
- **0.3% LOAD REGULATION**
- **0.01% / V LINE REGULATION**
- **COMPLETE SERIES OF PROTECTIONS:**
 - CURRENT LIMITING
 - THERMAL SHUTDOWN
 - SOA CONTROL

Pins 4,5 – Adjust
Pins 6,7,8,9,10,11,12,13 – V_{IN}
Pins 15,16,17,18,1,2 – V_{OUT}

DESCRIPTION

The IP117M Series are three terminal positive adjustable voltage regulators capable of supplying in excess of 0.5A over a 1.25V to 60V output range. These regulators are exceptionally easy to use and require only two external resistors to set the output voltage. In addition to improved line and load regulation, a major feature of the “A” series is the initial output voltage tolerance, which is guaranteed to be less than 1%.

Over full operating conditions, including load, line, and power dissipation, the reference voltage is guaranteed not to vary more than 2%. These devices exhibit current limit, thermal overload protection, and improved power device safe operating area protection, making them essentially indestructible.

ABSOLUTE MAXIMUM RATINGS ($T_{case} = 25^{\circ}C$ unless otherwise stated)

V_{I-O}	Input - Output Differential Voltage	– Standard	40V
		– HV Series	60V
P_D	Power Dissipation		Internally limited
T_J	Operating Junction Temperature Range		–55 to 150°C
T_{STG}	Storage Temperature		–65 to 150°C

Parameter	Test Conditions	IP117MAHV IP117MA			IP117MHV , IP117M			Units	
		Min.	Typ.	Max.	Min.	Typ.	Max.		
V _{REF} Reference Voltage	I _{OUT} = 10mA	1.238	1.25	1.262				V	
	I _{OUT} = 10mA to I _{MAX} V _{IN} - V _{OUT} = 3V to V _{MAX} P ≤ P _{MAX} T _J = -55 to +150°C	1.220	1.250	1.270	1.200	1.250	1.300	V	
$\frac{\Delta V_{OUT}}{\Delta V_{IN}}$ Line Regulation 1	V _{IN} - V _{OUT} = 3V to V _{MAX} T _J = -55 to +150°C		0.005	0.010		0.010	0.020	% / V	
			0.010	0.020		0.020	0.050		
$\frac{\Delta V_{OUT}}{\Delta I_{OUT}}$ Load Regulation 1	I _{OUT} = 10mA to I _{MAX}	V _{OUT} ≤ 5V		5	15		5	15	mV
		V _{OUT} ≥ 5V		0.1	0.3		0.1	0.3	%
	I _{OUT} = 10mA to I _{MAX} T _J = -55 to +150°C	V _{OUT} ≤ 5V		15	50		20	50	mV
		V _{OUT} ≥ 5V		0.3	1		0.3	1	%
Thermal Regulation	t _p = 20ms		0.002	0.020		0.030	0.070	%/W	
Ripple Rejection	V _{OUT} = 10V f = 120Hz	C _{ADJ} = 0		65			65	dB	
		C _{ADJ} = 10μF T _J = -55 to +150°C	66	80		66	80	dB	
I _{ADJ} Adjust Pin Current	T _J = -55 to +150°C		50	100		50	100	μA	
ΔI _{ADJ} Adjust Pin Current Change	I _{OUT} = 10mA to I _{MAX} T _J = -55 to +150°C V _{IN} - V _{OUT} = 2.5V to V _{MAX}		0.2	5		0.2	5	μA	
I _{MIN} Minimum Load Current	V _{IN} - V _{OUT} = 40V T _J = -55 to +150°C		3.5	5		3.5	5	mA	
	V _{IN} - V _{OUT} = 60V (HV SERIES) T _J = -55 to +150°C		3.5	7		3.5	7		
I _{CL} Current Limit	V _{IN} - V _{OUT} ≤ 15V T _J = -55 to +150°C		0.50	0.80		0.50	0.80	A	
	V _{IN} - V _{OUT} = 40V		0.15	0.20		0.15	0.20	A	
	V _{IN} - V _{OUT} = 60V (HV SERIES)			0.30			0.30		
$\frac{\Delta V_{OUT}}{\Delta TEMP}$ Temperature Stability	T _J = -55 to +150°C		1	2		1		%	
$\frac{\Delta V_{OUT}}{\Delta TIME}$ Long Term Stability	T _A = +125°C t = 1000 Hrs		0.3	1		0.3	1	%	
e _n RMS Output Noise (% of V _{OUT})	f = 10 Hz to 10 kHz		0.001			0.001		%	
R _{θJC} Thermal Resistance Junction to Case	LCC4 Package			13			13	°C/W	

1) Regulation is measured at constant junction temperature, using pulse testing at a low duty cycle. Changes in output voltage due to heating effects are covered under thermal regulation specifications.

2) Test Conditions unless otherwise stated: V_{IN} - V_{OUT} = 5V, T_J = 25°C, I_{OUT} = 0.1A, P_{MAX} = 10W, I_{MAX} = 0.5A
V_{MAX} = 40V for standard series, 60V for HV series.