

DATA SHEET

TDA1306T Noise shaping filter DAC

Product specification
Supersedes data of September 1994
File under Integrated Circuits, IC01

1998 Jan 06

Noise shaping filter DAC

TDA1306T

FEATURES

General

- Double-speed mode
- Digital volume control
- Soft mute function
- 12 dB attenuation
- Low power dissipation
- Digital de-emphasis
- TDA1305T pin compatible.

Easy application

- Voltage output
- Only 1st-order analog post-filtering required
- Operational amplifiers and digital filter integrated
- Selectable system clock (f_{sys}) $256f_s$ or $384f_s$
- I²S-bus ($f_{\text{sys}} = 256f_s$) or 16, 18 or 20 bits LSB fixed serial input format ($f_{\text{sys}} = 384f_s$)
- Single rail supply.

High performance

- Superior signal-to-noise ratio
- Wide dynamic range
- No zero crossing distortion
- Inherently monotonic
- Continuous calibration digital-to-analog conversion combined with noise shaping technique.

GENERAL DESCRIPTION

The TDA1306T is a dual CMOS digital-to-analog converter with up-sampling filter and noise shaper. The combination of oversampling up to $4f_s$, noise shaping and continuous calibration conversion ensures that only simple 1st-order analog post-filtering is required.

The TDA1306T supports the I²S-bus data input mode ($f_{\text{sys}} = 256f_s$) with word lengths of up to 20 bits and the LSB fixed serial data input format ($f_{\text{sys}} = 384f_s$) with word lengths of 16, 18 or 20 bits. Two cascaded IIR filters increase the sampling rate 4 times.

The DACs are of the continuous calibration type and incorporate a special data coding. This ensures a high signal-to-noise ratio, wide dynamic range and immunity to process variation and component ageing.

Two on-board operational amplifiers convert the digital-to-analog current to an output voltage.

ORDERING INFORMATION

TYPE NUMBER	PACKAGE		
	NAME	DESCRIPTION	VERSION
TDA1306T	SO24	plastic small outline package; 24 leads; body width 7.5 mm.	SOT137-1

Noise shaping filter DAC

TDA1306T

QUICK REFERENCE DATA

All power supply pins V_{DD} and V_{SS} must be connected to the same external supply unit.

SYMBOL	PARAMETER	CONDITIONS	MIN.	TYP.	MAX.	UNIT
Supply						
V_{DDD}	digital supply voltage		4.5	5.0	5.5	V
V_{DDA}	analog supply voltage		4.5	5.0	5.5	V
V_{DDO}	operational amplifier supply voltage		4.5	5.0	5.5	V
I_{DDD}	digital supply current	$V_{DDD} = 5\text{ V};$ at code 00000H	–	5	8	mA
I_{DDA}	analog supply current	$V_{DDA} = 5\text{ V};$ at code 00000H	–	3	5	mA
I_{DDO}	operational amplifier supply current	$V_{DDO} = 5\text{ V};$ at code 00000H	–	2	4	mA
Analog signals						
$V_{FS(rms)}$	full-scale output voltage (RMS value)	$V_{DDD} = V_{DDA} = V_{DDO} = 5\text{ V};$ $R_L > 5\text{ k}\Omega$	0.935	1.1	1.265	V
R_L	output load resistance		5	–	–	$\text{k}\Omega$
DAC performance						
(THD + N)/S	total harmonic distortion plus noise-to-signal ratio	at 0 dB signal level; $f_i = 1\text{ kHz};$	–	–70	–	dB
			–	0.032	–	%
		at –60 dB signal level; $f_i = 1\text{ kHz};$	–	–42	–32	dB
			–	0.8	2.5	%
S/N	signal-to-noise ratio	no signal; A-weighted	–	–108	–96	dB
BR	input bit rate at data input	$f_s = 44.1\text{ kHz};$ normal speed	–	–	2.822	Mbits/s
		$f_s = 44.1\text{ kHz};$ double speed	–	–	5.645	Mbits/s
f_{sys}	system clock frequency (pin 12)		6.4	–	18.432	MHz
T_{amb}	operating ambient temperature		–40	–	+85	$^{\circ}\text{C}$

Noise shaping filter DAC

TDA1306T

BLOCK DIAGRAM

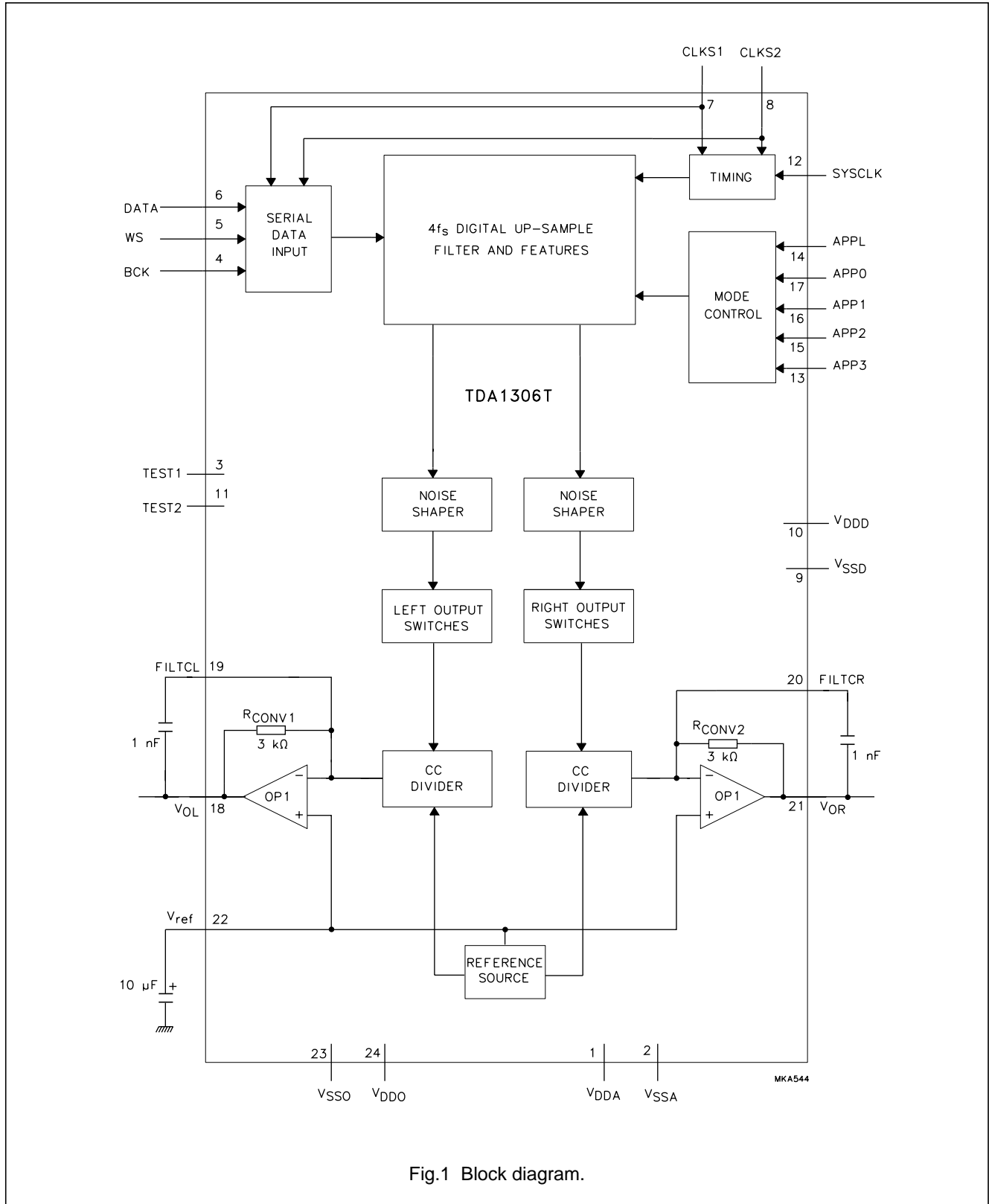

Fig.1 Block diagram.

Noise shaping filter DAC

TDA1306T

PINNING

SYMBOL	PIN	DESCRIPTION
V _{DDA}	1	analog supply voltage (+5 V)
V _{SSA}	2	analog ground
TEST1	3	test input 1; pin should be connected to ground
BCK	4	bit clock input
WS	5	word select input
DATA	6	data input
CLKS1	7	clock and format selection 1 input
CLKS2	8	clock and format selection 2 input
V _{SSD}	9	digital ground
V _{DDD}	10	digital supply voltage (+5 V)
TEST2	11	test input 2; pin should be connected to ground
SYSCLK	12	system clock input 256f _s or 384f _s
APP3	13	application mode 3 input
APPL	14	application mode selection input
APP2	15	application mode 2 input
APP1	16	application mode 1 input
APP0	17	application mode 0 input
V _{OL}	18	left channel output
FILTCL	19	capacitor for left channel 1st order filter function; should be connected between pins 19 and 18
FILTCR	20	capacitor for right channel 1st order filter function; should be connected between pins 20 and 21
V _{OR}	21	right channel output
V _{ref}	22	internal reference voltage for output channels; 0.5V _{DDO} (typ.)
V _{SSO}	23	operational amplifier ground
V _{DDO}	24	operational amplifier supply voltage

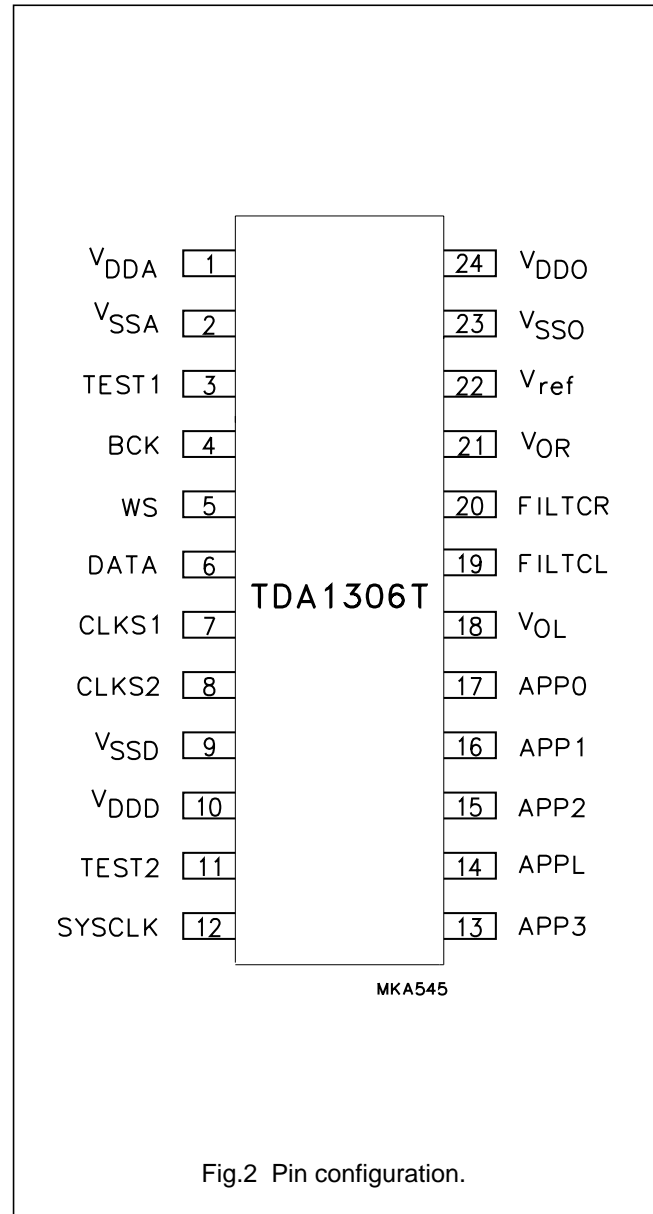

Fig.2 Pin configuration.

Noise shaping filter DAC

TDA1306T

FUNCTIONAL DESCRIPTION

The TDA1306T CMOS DAC incorporates an up-sampling filter, a noise shaper, continuous calibrated current sources and operational amplifiers.

System clock and data input format

The TDA1306T accommodates slave mode only. Consequently, in all applications, the system devices must provide the system clock. The system frequency is selectable at pins CLKS1 and CLKS2 (see Table 1).

The TDA1306T supports the following data input modes:

- I²S-bus with data word length of up to 20 bits ($f_{sys} = 256f_s$)
- LSB fixed serial format with data word length of 16, 18 or 20 bits ($f_{sys} = 384f_s$). As this format idles on the MSB it is necessary to know how many bits are being transmitted.

The input formats are illustrated in Fig.9. Left and right data channel words are time multiplexed.

Table 1 Data input format and system clock

CLKS1	CLKS2	DATA INPUT FORMAT	SYSTEM CLOCK	
			NORMAL SPEED	DOUBLE SPEED
0	0	I ² S-bus	256f _s	128f _s
0	1	LSB fixed 16 bits	384f _s	192f _s
1	0	LSB fixed 18 bits	384f _s	192f _s
1	1	LSB fixed 20 bits	384f _s	192f _s

Device operation

When the APPL pin is held HIGH and APP3 is held LOW, pins APP0, APP1 and APP2 form a microcontroller interface. When the APPL pin is held LOW, pins APP0, APP1, APP2 and APP3 form a pseudo-static application (TDA1305T pin compatible).

PSEUDO-STATIC APPLICATION MODE (APPL = LOGIC 0)

In this mode, the device operation is controlled by pseudo-static application pins where:

- APP0 = attenuation mode control
- APP1 = double-speed mode control
- APP2 = mute mode control
- APP3 = de-emphasis mode control.

In the pseudo-static application mode the TDA1306T is pin compatible with the TDA1305T slave mode. The correspondence between TDA1306T pin number, TDA1306T pin name, TDA1305T pin mnemonic and a description of the effects is given in Table 2.

Noise shaping filter DAC

TDA1306T

Table 2 Pseudo-static application mode

PIN MNEMONIC	PIN NUMBER	TDA1305T FUNCTION	VALUE	DESCRIPTION
APP0	17	ATSB	0	12 dB attenuation (from full scale) activated (only if MUSB = logic 1)
			1	full scale (only if MUSB = logic 1)
APP1	16	DSMB	0	double-speed mode
			1	normal-speed mode
APP2	15	MUSB	0	samples decrease to mute level
			1	level according to ATSB
APP3	13	DEEM1	0	de-emphasis OFF (44.1 kHz)
			1	de-emphasis ON (44.1 kHz)

MICROCONTROLLER APPLICATION MODE (APPL = LOGIC 1 AND APP3 = LOGIC 0)

In this mode, the device operation is controlled by a set of flags in an 8-bit mode control register. The 8-bit mode control register is written by a microcontroller interface where:

- APPL = logic 1
- APP0 = Data
- APP1 = Clock
- APP2 = RAB
- APP3 = logic 0.

The correspondence between serial-to-parallel conversion, mode control flags and a summary of the effect of the control flags is given in Table 3. Figures 3 and 4 illustrate the mode set timing.

MICROCONTROLLER WRITE OPERATION SEQUENCE

The microcontroller write operation follows the following sequence:

- APP2 is held LOW by the microcontroller
- Microcontroller data is clocked into the internal shift register on the LOW-to-HIGH transition on pin APP1
- Data D7 to D0 is latched into the appropriate control register on the LOW-to-HIGH transition of pin APP2 (APP1 = HIGH)
- If more data is clocked into the TDA1306T before the LOW-to-HIGH transition on pin APP2 then only the last 8 bits are used
- If less data is clocked into the TDA1306T unpredictable operation will result
- If the LOW-to-HIGH transition of pin APP2 occurs when APP1 = LOW, the command will be disregarded.

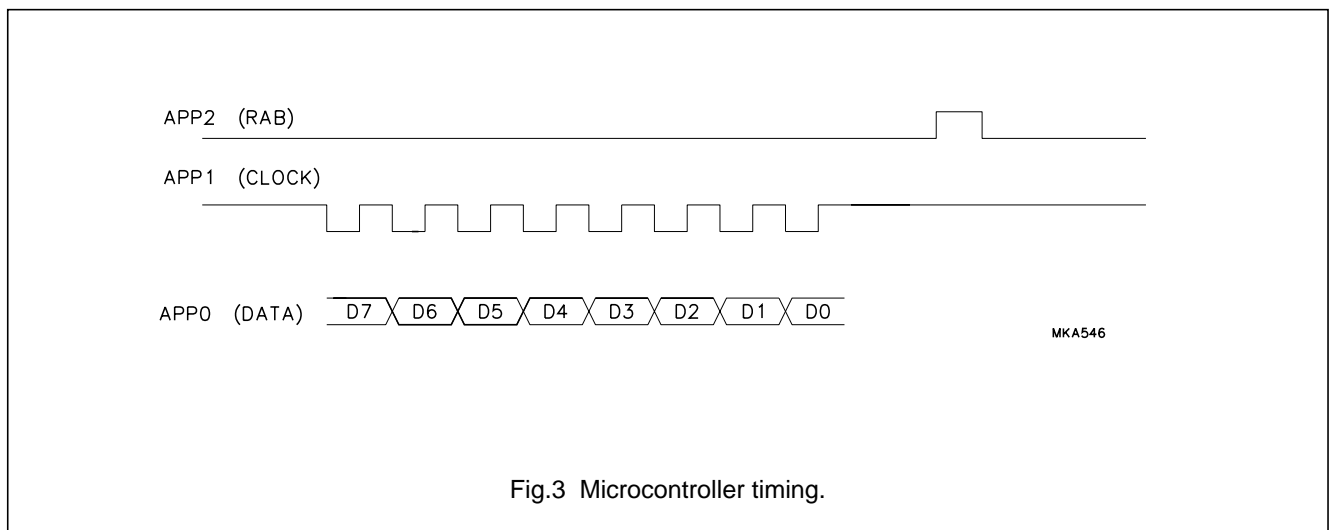

Fig.3 Microcontroller timing.

Noise shaping filter DAC

TDA1306T

MICROCONTROLLER WRITE OPERATION SEQUENCE (REPEAT MODE)

The same command can be repeated several times (e.g. for fade function) by applying APP2 pulses as shown in Fig.4. It should be noted that APP1 must stay HIGH

between APP2 pulses. A minimum pause of 22 μ s is necessary between any two step-up or step-down commands.

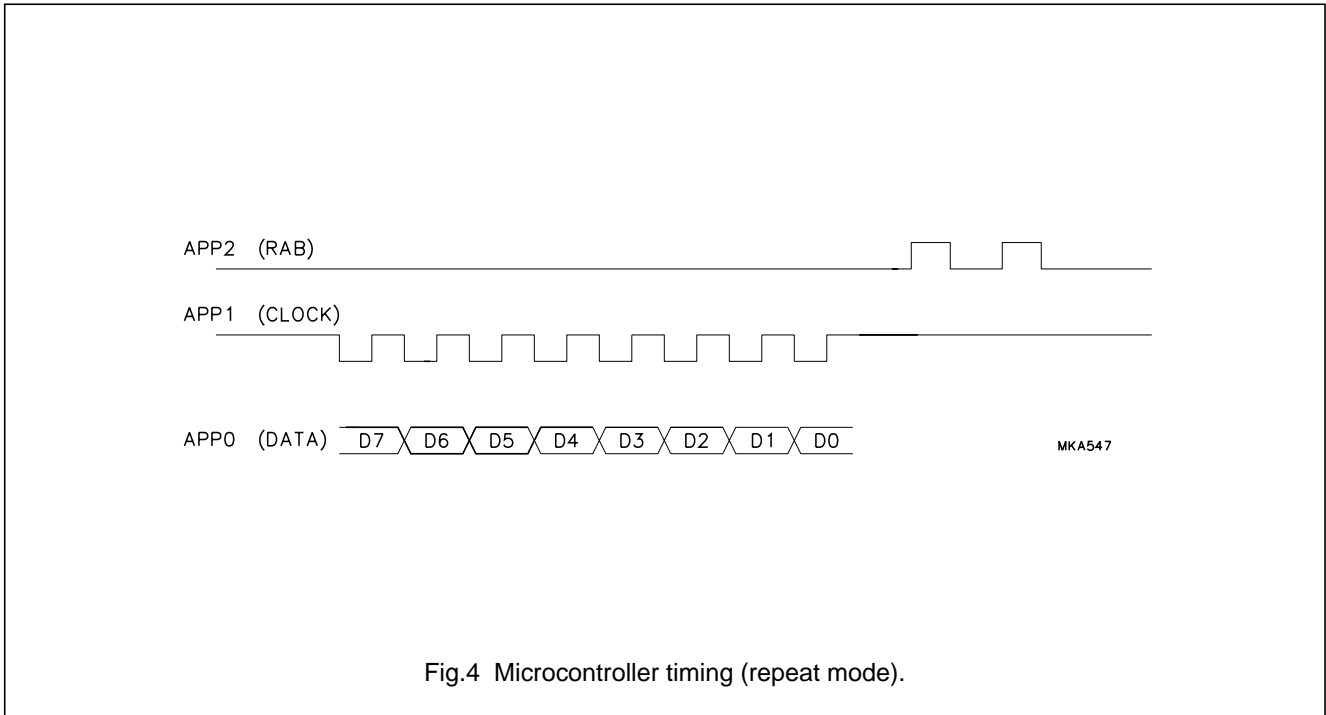

Table 3 Microcontroller mode control register

BIT POSITION	FUNCTION	DESCRIPTION	ACTIVE LEVEL
D7	ATSB	12 dB attenuation (from full scale)	LOW
D6	DSMB	double speed	LOW
D5	MUSB	mute	LOW
D4	DEEM	de-emphasis	HIGH
D3	FS	full scale	HIGH
D2	INCR	increment	HIGH
D1	DECR	decrement	HIGH
D0	not applicable	reserved	not applicable

Noise shaping filter DAC

TDA1306T

Volume control

A digital level control is incorporated in the TDA1306T which performs the function of soft mute and attenuation (pseudo-static application mode) or soft mute, attenuation, fade, increment and decrement (microcontroller application mode). The volume control of both channels can be varied in small step changes determined by the value of the internal fade counter where:

$$\text{Audio level} = \text{counter} \times \text{maximum level}/120.$$

Where the counter is a 7-bit binary number between 0 and 120. The time taken for mute to vary from 120 to 0 is $1/120f_s$. For example, when $f_s = 44.1 \text{ kHz}$, the time taken is approximately 3 ms.

VOLUME CONTROL (PSEUDO-STATIC APPLICATION MODE)

In the pseudo-static application mode (APPL = logic 0) the digital audio output level is controlled by APP0 (attenuation) and APP2 (mute) so only the final volume levels full scale, 12 dB (attenuate) and mute (-infinity dB) can be selected. The mute function has priority over the attenuation function. Accordingly, if MUSB is LOW, the state of ATSB has no effect. An example of volume control in this application mode is illustrated in Fig.5.

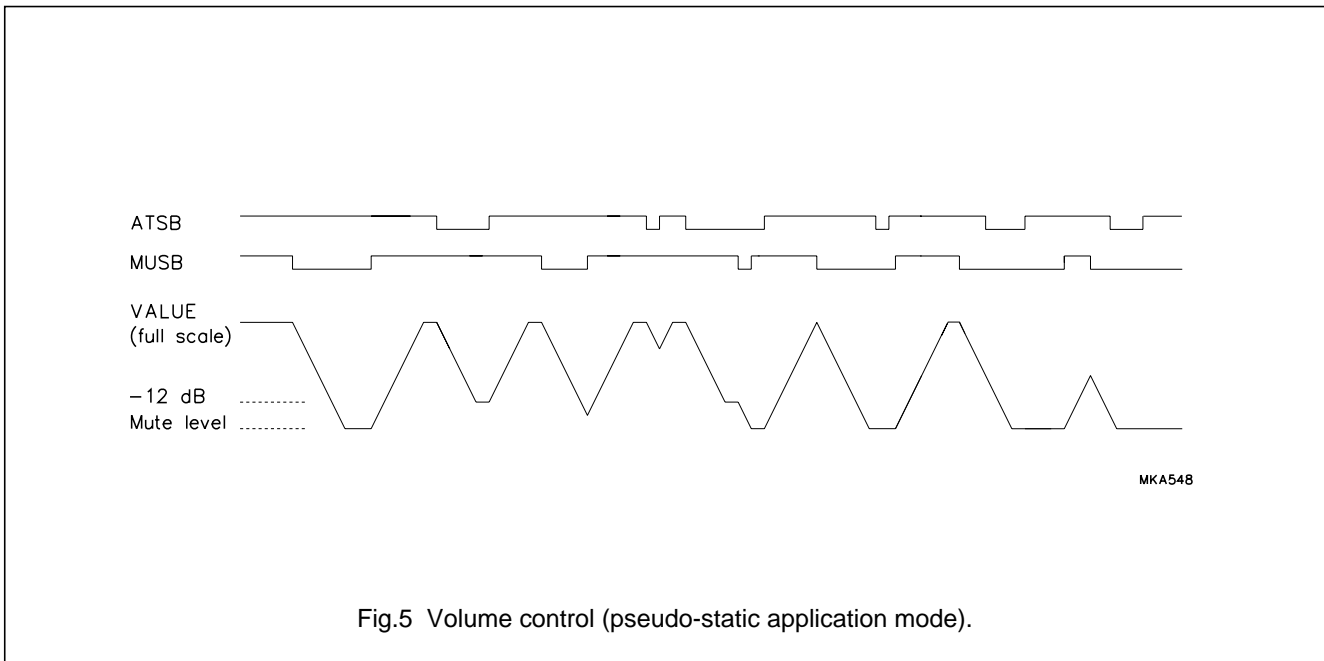

Fig.5 Volume control (pseudo-static application mode).

Noise shaping filter DAC

TDA1306T

VOLUME CONTROL (MICROCONTROLLER APPLICATION MODE)

In the microcontroller application mode (APPL = logic 1, APP3 = logic 0) the audio output level is controlled by volume control bits ATSB, MUSB, FS, INCR and DECR.

Mute is activated by sending the MUSB command to the mode control register via the microcontroller interface. The audio output level will be reduced to zero in a maximum of 120 steps (depending on the current position of the fade counter) and taking a maximum of 3 ms. Mute, attenuation and full scale are synchronized to prevent operation in the middle of a word.

- The counter is preset to 120 by the full scale command
- The counter is preset to 30 by the attenuate command when its value is more then 30. If the value of the counter is less than 30 dB the ATSB command has no effect.
- The counter is preset to logic 0 by the mute command MUSB
- Attenuation (-12 dB) is activated by sending the ATSB command to the fade control register (D7)
- Attenuation and mute are cancelled by sending the full-scale command to the fade control register (Register D3).

To control the fade counter in a continuous way, the INCREMENT and DECREMENT commands are available (fade control Registers D1 and D2). They will increment and decrement the counter by 1 for each register write operation. When issuing more than 1 step-up or step-down command in sequence, the write repeat mode may be used (see microcontroller application mode). An example of volume control in this application mode is illustrated in Fig.6.

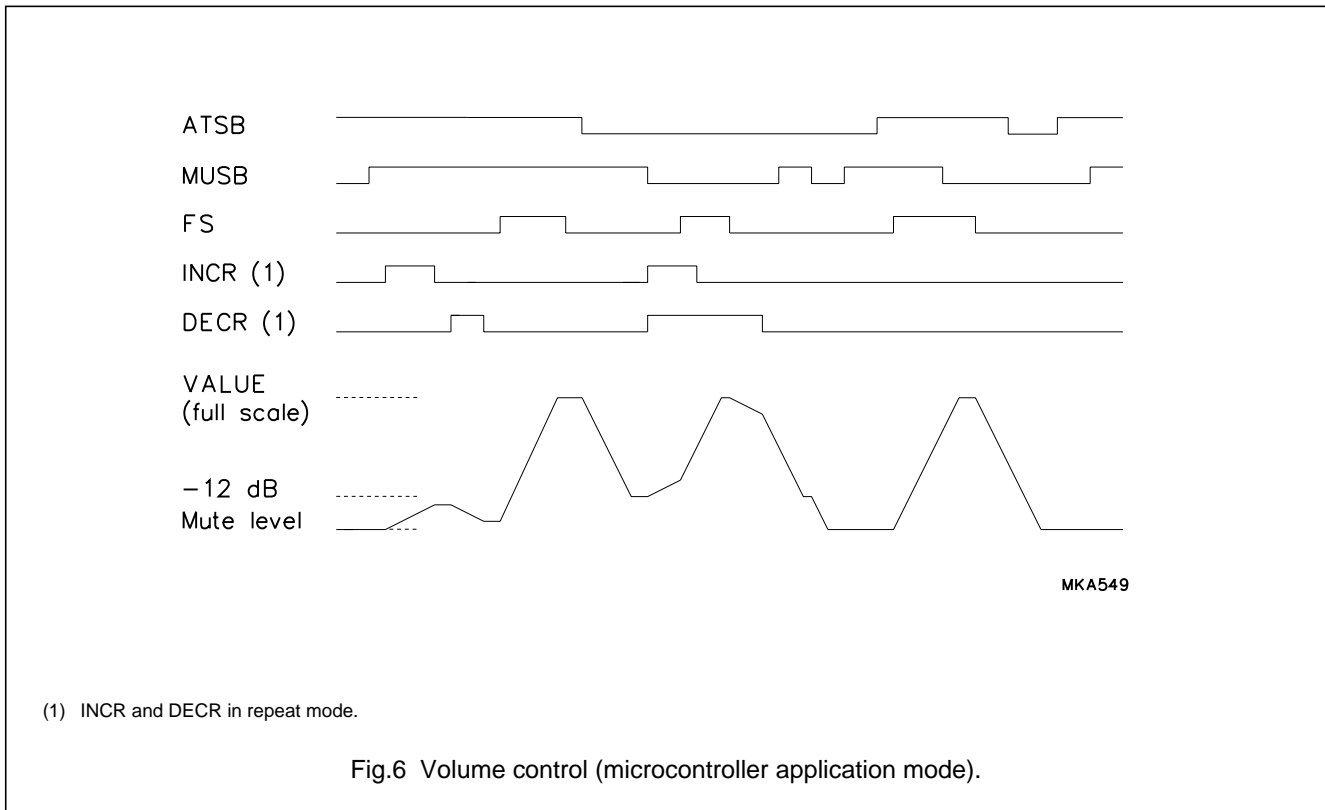

Noise shaping filter DAC

TDA1306T

There are two recommended application situations within the microcontroller mode:

- The customer wants to use the microcontroller interface without the volume setting facility. In this event the operation is as follows:
 - Mute ON; by sending the MUSB command
 - Mute OFF; by sending the FS command
 - Attenuation ON; by sending the ATSB command
 - Attenuation OFF; by sending the FS command.
 It is possible to switch from 'Attenuation ON' to 'Mute ON' but not vice-versa.

- Incorporating the volume control feature operates as follows:
 - Mute ON; by sending the MUSB command the microcontroller has to store the previous volume setting
 - Mute OFF; by sending succeeding INCR commands until the previous volume is reached
 - Attenuation ON; by sending succeeding DECR commands until a relative downstep of -12 dB is reached.
The microcontroller has to store the previous volume
 - Attenuation OFF; by sending the succeeding INCR commands until the previous volume is reached
 - Volume UP; by sending succeeding INCR commands
 - Volume DOWN; by sending succeeding DECR commands.

De-emphasis

A digital de-emphasis is implemented in the TDA1306T. By selecting the DEEM bit at register D4 (microcontroller application mode) or activating the APP3 pin (pseudo-static application mode), de-emphasis can be applied by means of an IIR filter. De-emphasis is synchronized to prevent operation in the middle of a word.

Double-speed mode

The double-speed mode is controlled by the DSMB bit at register D6 (microcontroller application mode) or by activating the APP1 pin (pseudo-static application mode). When the control bit is active LOW the device operates in the double-speed mode.

Oversampling filter and noise shaper

The digital filter is a four times oversampling filter. It consists of two sections which each increase the sample rate by 2. The noise-shaper operates on $4f_s$ and reduces the in-band noise density.

DAC and operational amplifiers

In this noise shaping filter DAC a special data code and bidirectional current sources are used in order to achieve true low-noise performance. The special data code guarantees that only small values of current flow to the output during small signal passages while larger positive or negative values are generated using the bidirectional current sources. The noise shaping filter-DAC uses the continuous calibration conversion technique.

The operational amplifiers and the internal conversion resistors R_{CONV1} and R_{CONV2} convert the DAC current to an output voltage available at V_{OL} and V_{OR} . Connecting an external capacitor between $FILTCL$ and V_{OL} , $FILTCR$ and V_{OR} respectively provides the required 1st-order post filtering.

Noise shaping filter DAC

TDA1306T

LIMITING VALUES

In accordance with the Absolute Maximum Rating System (IEC 134).

SYMBOL	PARAMETER	CONDITIONS	MIN.	MAX.	UNIT
V_{DD}	supply voltage	note 1	–	7.0	V
T_{xtal}	maximum crystal temperature		–	+150	°C
T_{stg}	storage temperature		–65	+125	°C
T_{amb}	operating ambient temperature		–40	+85	°C
V_{es}	electrostatic handling	note 2	–2000	+2000	V
		note 3	–200	+200	V

Notes

1. All V_{DD} and V_{SS} connections must be made to the same power supply.
2. Equivalent to discharging a 100 pF capacitor via a 1.5 k Ω series resistor.
3. Equivalent to discharging a 200 pF capacitor via a 2.5 mH series inductor.

THERMAL CHARACTERISTICS

SYMBOL	PARAMETER	CONDITIONS	VALUE	UNIT
$R_{th\ j-a}$	thermal resistance from junction to ambient	in free air	69	K/W

QUALITY SPECIFICATION

In accordance with "UZW-BO/FQ-0601".

Noise shaping filter DAC

TDA1306T

DC CHARACTERISTICS

$V_{DD} = V_{DDA} = V_{DDO} = 5\text{ V}$; $T_{\text{amb}} = 25\text{ }^{\circ}\text{C}$; all voltages referenced to ground (pins 2, 9 and 23); unless otherwise specified.

SYMBOL	PARAMETER	CONDITIONS	MIN.	TYP.	MAX.	UNIT
V_{DD}	digital supply voltage (pin 10)	note 1	4.5	5.0	5.5	V
V_{DDA}	analog supply voltage (pin 1)	note 1	4.5	5.0	5.5	V
V_{DDO}	operational amplifier supply voltage (pin 24)	note 1	4.5	5.0	5.5	V
I_{DD}	digital supply current	$f_{\text{sys}} = 11.28\text{ MHz}$	–	5	8	mA
I_{DDA}	analog supply current	at digital silence	–	3	6	mA
I_{DDO}	operational amplifier supply current	no operational amplifier load resistor	–	2	4	mA
P_{tot}	total power dissipation	$f_{\text{sys}} = 11.28\text{ MHz}$; digital silence; no operational amplifier load resistor	–	50	90	mW
V_{IH}	HIGH level digital input voltage (pins 3 to 8 and 11 to 17)		$0.7V_{DD}$	–	$V_{DD} + 0.5$	V
V_{IL}	LOW level digital input voltage (pins 3 to 8 and 11 to 17)		–0.5	–	$+0.3V_{DD}$	V
R_{pd}	internal pull-down resistor to V_{SS} (pins 3 and 11)		17	–	134	k Ω
$ I_{\text{LI}} $	input leakage current		–	–	10	μA
C_{i}	input capacitance		–	–	10	pF
V_{ref}	reference voltage (pin 22)	with respect to V_{SSO}	$0.45V_{DDO}$	$0.5V_{DDO}$	$0.55V_{DDO}$	V
R_{CONV}	current-to-voltage conversion resistor		2.4	3.0	3.6	k Ω
$V_{\text{FS(rms)}}$	full-scale output voltage (RMS value)	$R_{\text{L}} > 5\text{ k}\Omega$; note 2	0.935	1.1	1.265	V
R_{L}	output load resistance		5	–	–	k Ω

Notes

1. All power supply pins (V_{DD} and V_{SS}) must be connected to the same external power supply unit.
2. R_{L} is the AC resistance of the external circuitry connected to the audio outputs of the application circuit.

Noise shaping filter DAC

TDA1306T

AC CHARACTERISTICS (ANALOG)

$V_{DD} = V_{DDA} = V_{DDO} = 5\text{ V}$; $T_{amb} = 25\text{ }^{\circ}\text{C}$; all voltages referenced to ground (pins 2, 9 and 23); unless otherwise specified.

SYMBOL	PARAMETER	CONDITIONS	MIN.	TYP.	MAX.	UNIT
DACs						
SVRR	supply voltage ripple rejection V_{DDA} and V_{DDO}	$f_{\text{ripple}} = 1\text{ kHz}$; $V_{\text{ripple}} = 100\text{ mV (p-p)}$; $C22 = 10\text{ }\mu\text{F}$	–	40	–	dB
ΔG_v	unbalance between the 2 DAC voltage outputs (pins 18 and 21)	maximum volume	–	–	0.5	dB
α_{ct}	crosstalk between the 2 DAC voltage outputs (pins 18 and 21)	one output digital silence the other maximum volume	–	–110	–85	dB
(THD + N)/S	total harmonic distortion plus noise-to-signal ratio	at 0 dB signal level; $f_i = 1\text{ kHz}$	–	–70	–	dB
			–	0.032	–	%
		at –60 dB signal level; $f_i = 1\text{ kHz}$	–	–42	–32	dB
			–	0.8	2.5	%
S/N	signal-to-noise ratio	no signal; A-weighted	–	–108	–96	dB
Operational amplifiers						
G_v	open-loop voltage gain		–	85	–	dB
PSRR	power supply rejection ratio	$f_{\text{ripple}} = 3\text{ kHz}$; $V_{\text{ripple}} = 100\text{ mV (p-p)}$; A-weighted	–	90	–	dB
(THD + N)/S	total harmonic distortion plus noise-to-signal ratio	$R_L > 5\text{ k}\Omega$; $f_i = 1\text{ kHz}$; $V_o = 2.8\text{ V (p-p)}$	–	–100	–	dB
f_{UG}	unity gain frequency	open loop	–	4.5	–	MHz
$ Z_o $	AC output impedance	$R_L > 5\text{ k}\Omega$	–	1.5	150	Ω

Noise shaping filter DAC

TDA1306T

AC CHARACTERISTICS (DIGITAL)

$V_{DD} = V_{DDA} = V_{DDO}$ 4.5 to 5.5 V; all voltages referenced to ground (pins 2, 9 and 23); $T_{amb} = -40$ to $+85$ °C; unless otherwise specified.

SYMBOL	PARAMETER	CONDITIONS	MIN.	TYP.	MAX.	UNIT
T_{WX}	clock cycle time	$f_{sys} = 384f_s$; normal speed	54.2	59.1	104	ns
		$f_{sys} = 192f_s$; double speed	54.2	59.1	104	ns
		$f_{sys} = 256f_s$; normal speed	81.3	88.6	156	ns
		$f_{sys} = 128f_s$; double speed	81.3	88.6	156	ns
t_{CWL}	f_{sys} LOW level pulse width		22	–	–	ns
t_{CWH}	f_{sys} HIGH level pulse width		22	–	–	ns
Serial input data timing (see Fig.8)						
f_s	word select input audio sample frequency	normal speed	25	44.1	48	kHz
		double speed	50	88.2	96	kHz
f_{BCK}	clock input frequency (data input rate)	$f_{sys} = 384f_s$; normal speed; note 1	–	–	$64f_s$	kHz
		$f_{sys} = 192f_s$; double speed; note 1	–	–	$64f_s$	kHz
		$f_{sys} = 256f_s$; normal speed	–	–	$64f_s$	kHz
		$f_{sys} = 128f_s$; double speed; note 2	–	–	$48f_s$	kHz
t_r	rise time		–	–	20	ns
t_f	fall time		–	–	20	ns
t_H	bit clock HIGH time		55	–	–	ns
t_L	bit clock LOW time		55	–	–	ns
t_{su}	data set-up time		20	–	–	ns
t_h	data hold time		10	–	–	ns
t_{suWS}	word select set-up time		20	–	–	ns
t_{hWS}	word select hold time		10	–	–	ns
Microcontroller interface timing (see Fig.9)						
t_L	input LOW time		2	–	–	μ s
t_H	Input HIGH time		2	–	–	μ s
t_{suDC}	set-up time DATA to CLOCK		1	–	–	μ s
t_{hCD}	hold time CLOCK to DATA		1	–	–	μ s
t_{suCR}	set-up time CLOCK to RAB		1	–	–	μ s

Notes

1. A clock frequency of up to $96f_s$ is possible in the event of a rising edge of BCK occurring during $SYSCLK = LOW$.
2. A clock frequency of up to $64f_s$ is possible in the event of a rising edge of BCK occurring during $SYSCLK = LOW$.

Noise shaping filter DAC

TDA1306T

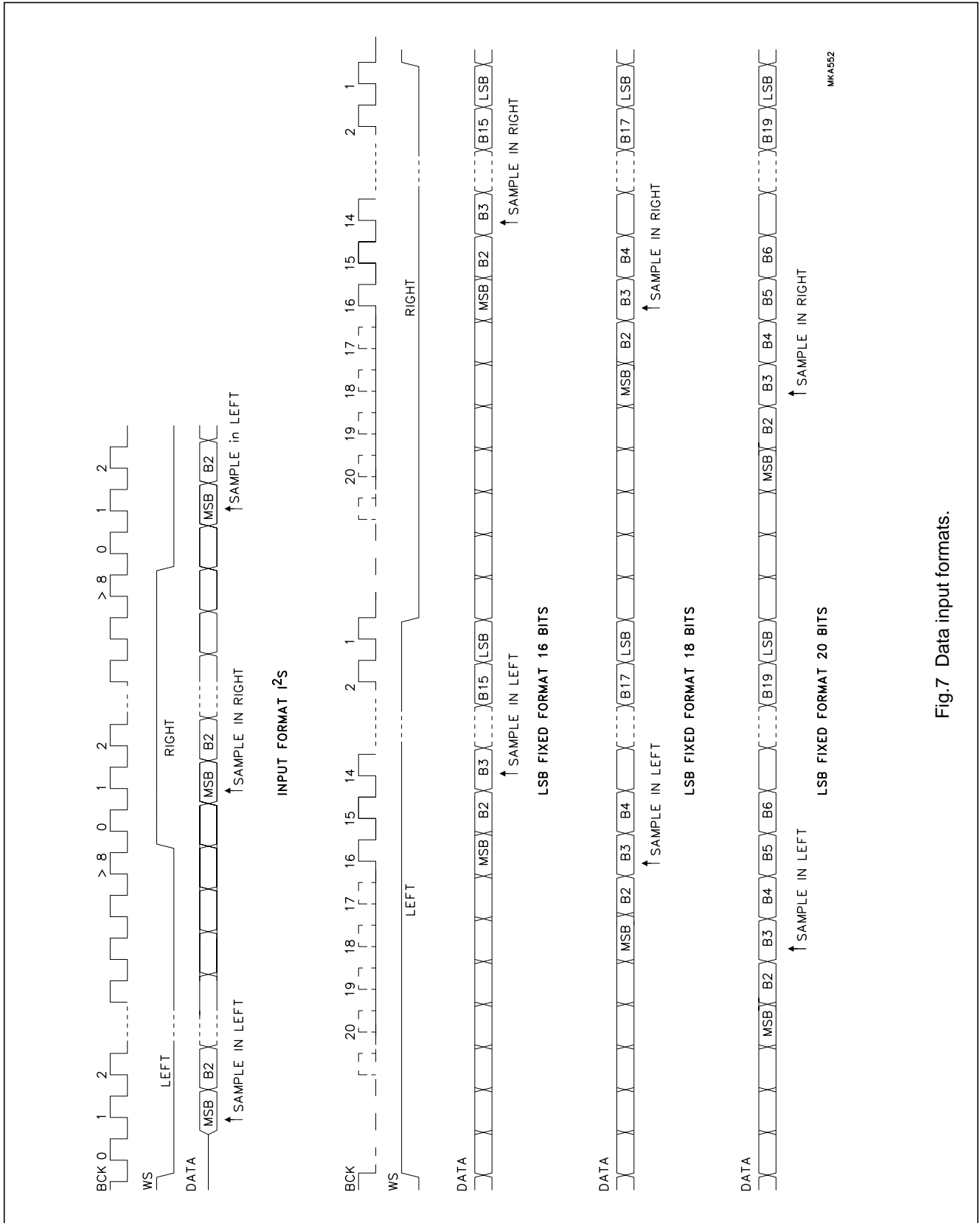
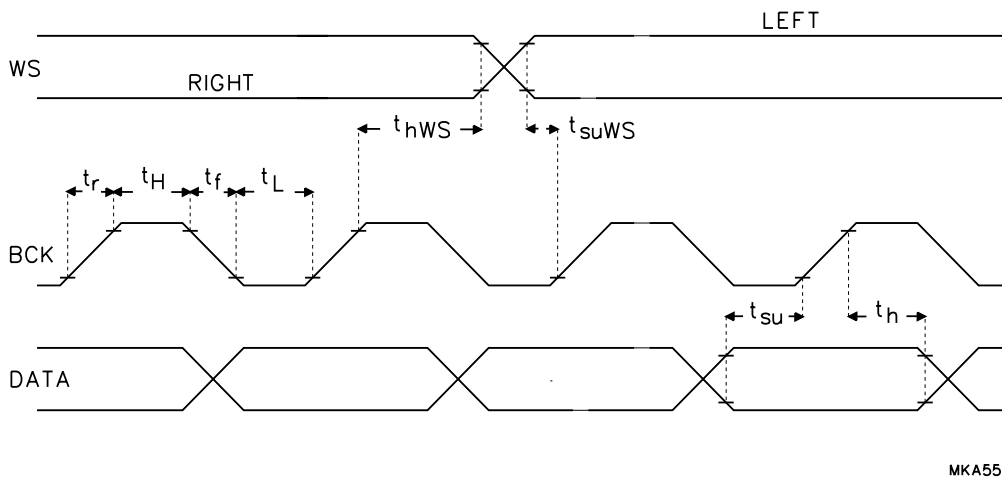

Fig.7 Data input formats.

Noise shaping filter DAC

TDA1306T



MKA550

Fig.8 Timing of input signals.

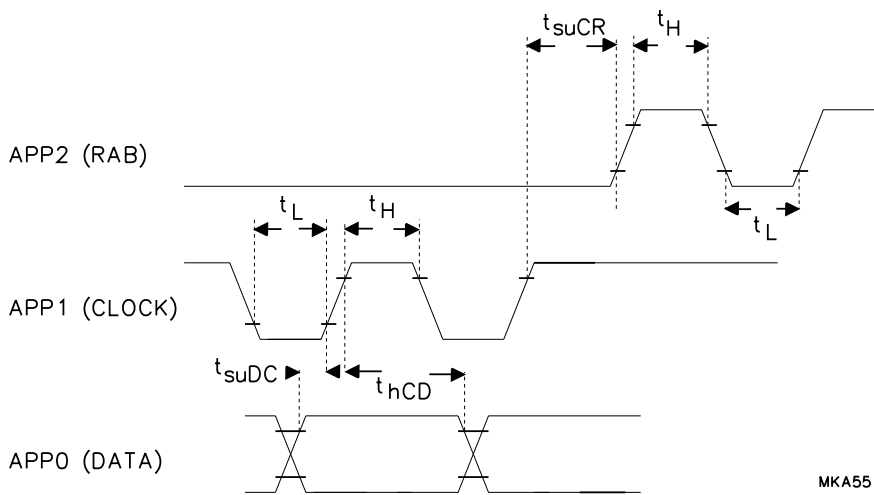

MKA551

Fig.9 Microcontroller timing.

Noise shaping filter DAC

TDA1306T

TEST AND APPLICATION INFORMATION**Filter characteristics****Table 4** Digital filter specification ($f_s = 44.1$ kHz)

BAND	ATTENUATION
0 to 19 kHz	< 0.001 dB
19 to 20 kHz	< 0.03 dB
24 kHz	> 25 dB
25 to 35 kHz	> 40 dB
35 to 64 kHz	> 50 dB
64 to 68 kHz	> 31 dB
68 kHz	> 35 dB
69 to 88 kHz	> 40 dB

Table 5 Digital filter phase distortion ($f_s = 44.1$ kHz)

BAND	PHASE DISTORTION
0 to 16 kHz	< $\pm 1^\circ$

Noise shaping filter DAC

TDA1306T

PACKAGE OUTLINE

SO24: plastic small outline package; 24 leads; body width 7.5 mm

SOT137-1

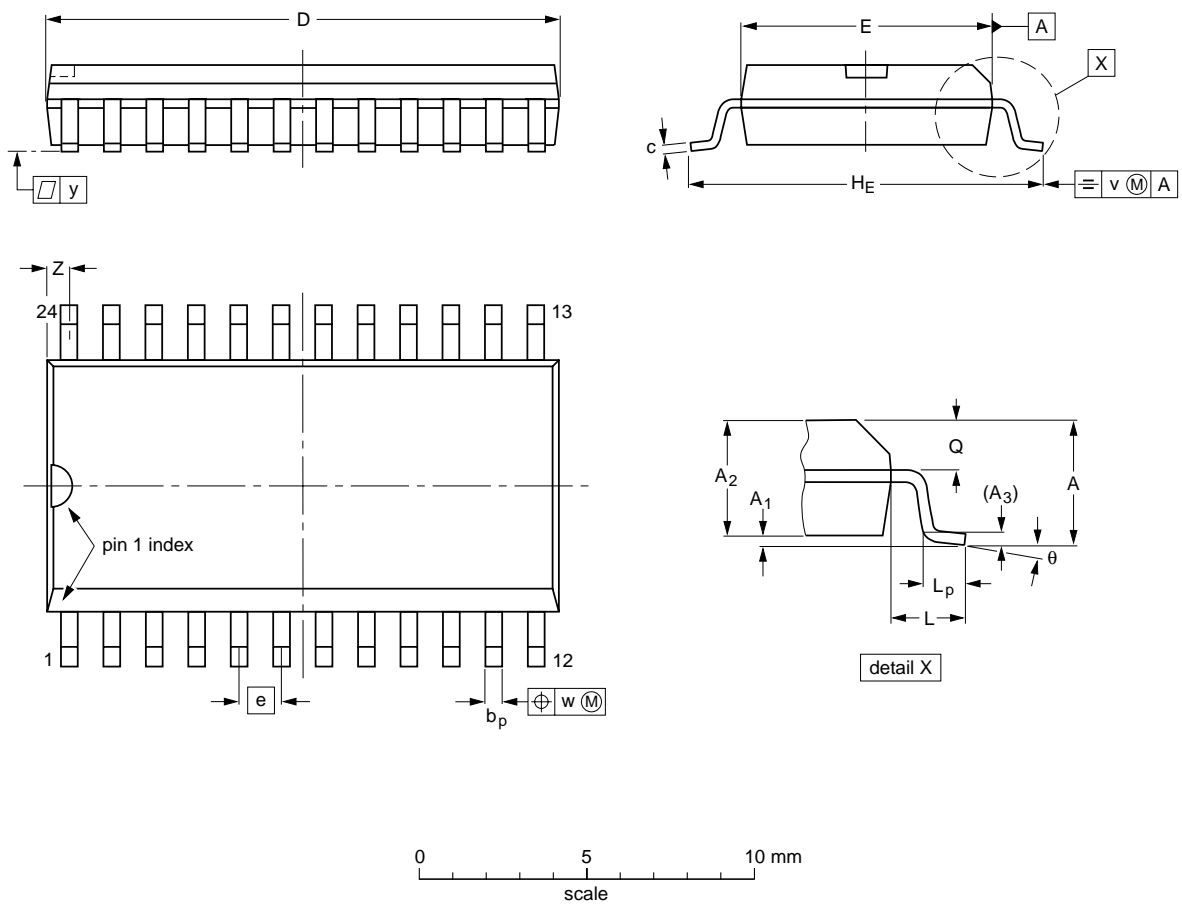

DIMENSIONS (inch dimensions are derived from the original mm dimensions)

UNIT	A max.	A ₁	A ₂	A ₃	b _p	c	D ⁽¹⁾	E ⁽¹⁾	e	H _E	L	L _p	Q	v	w	y	Z ⁽¹⁾	θ
mm	2.65	0.30 0.10	2.45 2.25	0.25	0.49 0.36	0.32 0.23	15.6 15.2	7.6 7.4	1.27	10.65 10.00	1.4	1.1 0.4	1.1 1.0	0.25	0.25	0.1	0.9 0.4	8° 0°
inches	0.10	0.012 0.004	0.096 0.089	0.01	0.019 0.014	0.013 0.009	0.61 0.60	0.30 0.29	0.050	0.419 0.394	0.055	0.043 0.016	0.043 0.039	0.01	0.01	0.004	0.035 0.016	

Note

1. Plastic or metal protrusions of 0.15 mm maximum per side are not included.

OUTLINE VERSION	REFERENCES				EUROPEAN PROJECTION	ISSUE DATE
	IEC	JEDEC	EIAJ			
SOT137-1	075E05	MS-013AD				95-01-24 97-05-22

Noise shaping filter DAC

TDA1306T

SOLDERING

Introduction

There is no soldering method that is ideal for all IC packages. Wave soldering is often preferred when through-hole and surface mounted components are mixed on one printed-circuit board. However, wave soldering is not always suitable for surface mounted ICs, or for printed-circuits with high population densities. In these situations reflow soldering is often used.

This text gives a very brief insight to a complex technology. A more in-depth account of soldering ICs can be found in our *"IC Package Databook"* (order code 9398 652 90011).

Reflow soldering

Reflow soldering techniques are suitable for all SO packages.

Reflow soldering requires solder paste (a suspension of fine solder particles, flux and binding agent) to be applied to the printed-circuit board by screen printing, stencilling or pressure-syringe dispensing before package placement.

Several techniques exist for reflowing; for example, thermal conduction by heated belt. Dwell times vary between 50 and 300 seconds depending on heating method. Typical reflow temperatures range from 215 to 250 °C.

Preheating is necessary to dry the paste and evaporate the binding agent. Preheating duration: 45 minutes at 45 °C.

Wave soldering

Wave soldering techniques can be used for all SO packages if the following conditions are observed:

- A double-wave (a turbulent wave with high upward pressure followed by a smooth laminar wave) soldering technique should be used.
- The longitudinal axis of the package footprint must be parallel to the solder flow.
- The package footprint must incorporate solder thieves at the downstream end.

During placement and before soldering, the package must be fixed with a droplet of adhesive. The adhesive can be applied by screen printing, pin transfer or syringe dispensing. The package can be soldered after the adhesive is cured.

Maximum permissible solder temperature is 260 °C, and maximum duration of package immersion in solder is 10 seconds, if cooled to less than 150 °C within 6 seconds. Typical dwell time is 4 seconds at 250 °C.

A mildly-activated flux will eliminate the need for removal of corrosive residues in most applications.

Repairing soldered joints

Fix the component by first soldering two diagonally-opposite end leads. Use only a low voltage soldering iron (less than 24 V) applied to the flat part of the lead. Contact time must be limited to 10 seconds at up to 300 °C. When using a dedicated tool, all other leads can be soldered in one operation within 2 to 5 seconds between 270 and 320 °C.

Noise shaping filter DAC

TDA1306T

DEFINITIONS

Data sheet status	
Objective specification	This data sheet contains target or goal specifications for product development.
Preliminary specification	This data sheet contains preliminary data; supplementary data may be published later.
Product specification	This data sheet contains final product specifications.
Limiting values	
Limiting values given are in accordance with the Absolute Maximum Rating System (IEC 134). Stress above one or more of the limiting values may cause permanent damage to the device. These are stress ratings only and operation of the device at these or at any other conditions above those given in the Characteristics sections of the specification is not implied. Exposure to limiting values for extended periods may affect device reliability.	
Application information	
Where application information is given, it is advisory and does not form part of the specification.	

LIFE SUPPORT APPLICATIONS

These products are not designed for use in life support appliances, devices, or systems where malfunction of these products can reasonably be expected to result in personal injury. Philips customers using or selling these products for use in such applications do so at their own risk and agree to fully indemnify Philips for any damages resulting from such improper use or sale.

Noise shaping filter DAC

TDA1306T

NOTES

Noise shaping filter DAC

TDA1306T

NOTES

Philips Semiconductors – a worldwide company

Argentina: see South America

Australia: 34 Waterloo Road, NORTH RYDE, NSW 2113,
Tel. +61 2 9805 4455, Fax. +61 2 9805 4466

Austria: Computerstr. 6, A-1101 WIEN, P.O. Box 213, Tel. +43 160 1010,
Fax. +43 160 101 1210

Belarus: Hotel Minsk Business Center, Bld. 3, r. 1211, Volodarski Str. 6,
220050 MINSK, Tel. +375 172 200 733, Fax. +375 172 200 773

Belgium: see The Netherlands

Brazil: see South America

Bulgaria: Philips Bulgaria Ltd., Energoproject, 15th floor,
51 James Bourchier Blvd., 1407 SOFIA,
Tel. +359 2 689 211, Fax. +359 2 689 102

Canada: PHILIPS SEMICONDUCTORS/COMPONENTS,
Tel. +1 800 234 7381

China/Hong Kong: 501 Hong Kong Industrial Technology Centre,
72 Tat Chee Avenue, Kowloon Tong, HONG KONG,
Tel. +852 2319 7888, Fax. +852 2319 7700

Colombia: see South America

Czech Republic: see Austria

Denmark: Prags Boulevard 80, PB 1919, DK-2300 COPENHAGEN S,
Tel. +45 32 88 2636, Fax. +45 31 57 0044

Finland: Sinikalliontie 3, FIN-02630 ESPOO,
Tel. +358 9 615800, Fax. +358 9 61580920

France: 51 Rue Carnot, BP317, 92156 SURESNES Cedex,
Tel. +33 1 40 99 6161, Fax. +33 1 40 99 6427

Germany: Hammerbrookstraße 69, D-20097 HAMBURG,
Tel. +49 40 23 53 60, Fax. +49 40 23 536 300

Greece: No. 15, 25th March Street, GR 17778 TAVROS/ATHENS,
Tel. +30 1 4894 339/239, Fax. +30 1 4814 240

Hungary: see Austria

India: Philips INDIA Ltd, Band Box Building, 2nd floor,
254-D, Dr. Annie Besant Road, Worli, MUMBAI 400 025,
Tel. +91 22 493 8541, Fax. +91 22 493 0966

Indonesia: see Singapore

Ireland: Newstead, Clonskeagh, DUBLIN 14,
Tel. +353 1 7640 000, Fax. +353 1 7640 200

Israel: RAPAC Electronics, 7 Kehilat Saloniki St, PO Box 18053,
TEL AVIV 61180, Tel. +972 3 645 0444, Fax. +972 3 649 1007

Italy: PHILIPS SEMICONDUCTORS, Piazza IV Novembre 3,
20124 MILANO, Tel. +39 2 6752 2531, Fax. +39 2 6752 2557

Japan: Philips Bldg 13-37, Kohnan 2-chome, Minato-ku, TOKYO 108,
Tel. +81 3 3740 5130, Fax. +81 3 3740 5077

Korea: Philips House, 260-199 Itaewon-dong, Yongsan-ku, SEOUL,
Tel. +82 2 709 1412, Fax. +82 2 709 1415

Malaysia: No. 76 Jalan Universiti, 46200 PETALING JAYA, SELANGOR,
Tel. +60 3 750 5214, Fax. +60 3 757 4880

Mexico: 5900 Gateway East, Suite 200, EL PASO, TEXAS 79905,
Tel. +9-5 800 234 7381

Middle East: see Italy

Netherlands: Postbus 90050, 5600 PB EINDHOVEN, Bldg. VB,
Tel. +31 40 27 82785, Fax. +31 40 27 88399

New Zealand: 2 Wagener Place, C.P.O. Box 1041, AUCKLAND,
Tel. +64 9 849 4160, Fax. +64 9 849 7811

Norway: Box 1, Manglerud 0612, OSLO,
Tel. +47 22 74 8000, Fax. +47 22 74 8341

Philippines: Philips Semiconductors Philippines Inc.,
106 Valero St. Salcedo Village, P.O. Box 2108 MCC, MAKATI,
Metro MANILA, Tel. +63 2 816 6380, Fax. +63 2 817 3474

Poland: Ul. Lukiska 10, PL 04-123 WARSZAWA,
Tel. +48 22 612 2831, Fax. +48 22 612 2327

Portugal: see Spain

Romania: see Italy

Russia: Philips Russia, Ul. Usatcheva 35A, 119048 MOSCOW,
Tel. +7 095 755 6918, Fax. +7 095 755 6919

Singapore: Lorong 1, Toa Payoh, SINGAPORE 1231,
Tel. +65 350 2538, Fax. +65 251 6500

Slovakia: see Austria

Slovenia: see Italy

South Africa: S.A. PHILIPS Pty Ltd., 195-215 Main Road Martindale,
2092 JOHANNESBURG, P.O. Box 7430 Johannesburg 2000,
Tel. +27 11 470 5911, Fax. +27 11 470 5494

South America: Al. Vicente Pinzon, 173, 6th floor,
04547-130 SÃO PAULO, SP, Brazil,
Tel. +55 11 821 2333, Fax. +55 11 821 2382

Spain: Balmes 22, 08007 BARCELONA,
Tel. +34 3 301 6312, Fax. +34 3 301 4107

Sweden: Kottbygatan 7, Akalla, S-16485 STOCKHOLM,
Tel. +46 8 632 2000, Fax. +46 8 632 2745

Switzerland: Allmendstrasse 140, CH-8027 ZÜRICH,
Tel. +41 1 488 2686, Fax. +41 1 488 3263

Taiwan: Philips Semiconductors, 6F, No. 96, Chien Kuo N. Rd., Sec. 1,
TAIPEI, Taiwan Tel. +886 2 2134 2865, Fax. +886 2 2134 2874

Thailand: PHILIPS ELECTRONICS (THAILAND) Ltd.,
209/2 Sanpavuth-Bangna Road Prakanong, BANGKOK 10260,
Tel. +66 2 745 4090, Fax. +66 2 398 0793

Turkey: Talatpasa Cad. No. 5, 80640 GÜLTEPE/ISTANBUL,
Tel. +90 212 279 2770, Fax. +90 212 282 6707

Ukraine: PHILIPS UKRAINE, 4 Patrice Lumumba str., Building B, Floor 7,
252042 KIEV, Tel. +380 44 264 2776, Fax. +380 44 268 0461

United Kingdom: Philips Semiconductors Ltd., 276 Bath Road, Hayes,
MIDDLESEX UB3 5BX, Tel. +44 181 730 5000, Fax. +44 181 754 8421

United States: 811 East Arques Avenue, SUNNYVALE, CA 94088-3409,
Tel. +1 800 234 7381

Uruguay: see South America

Vietnam: see Singapore

Yugoslavia: PHILIPS, Trg N. Pasica 5/v, 11000 BEOGRAD,
Tel. +381 11 625 344, Fax. +381 11 635 777

For all other countries apply to: Philips Semiconductors,
International Marketing & Sales Communications, Building BE-p, P.O. Box 218,
5600 MD EINDHOVEN, The Netherlands, Fax. +31 40 27 24825

Internet: <http://www.semiconductors.philips.com>

© Philips Electronics N.V. 1998

SCA57

All rights are reserved. Reproduction in whole or in part is prohibited without the prior written consent of the copyright owner.

The information presented in this document does not form part of any quotation or contract, is believed to be accurate and reliable and may be changed without notice. No liability will be accepted by the publisher for any consequence of its use. Publication thereof does not convey nor imply any license under patent- or other industrial or intellectual property rights.

Printed in The Netherlands

547027/1200/02/pp24

Date of release: 1998 Jan 06

Document order number: 9397 750 03168

Let's make things better.

**Philips
Semiconductors**



PHILIPS