

MC74HC4851A, MC74HC4852A

Analog Multiplexers/ Demultiplexers with Injection Current Effect Control

Automotive Customized

These devices are pin compatible to standard HC405x and MC1405xB analog mux/demux devices, but feature injection current effect control. This makes them especially suited for usage in automotive applications where voltages in excess of normal logic voltage are common.

The injection current effect control allows signals at disabled analog input channels to exceed the supply voltage range without affecting the signal of the enabled analog channel. This eliminates the need for external diode/ resistor networks typically used to keep the analog channel signals within the supply voltage range.

The devices utilize low power silicon gate CMOS technology. The Channel Select and Enable inputs are compatible with standard CMOS outputs.

- Injection Current Cross-Coupling Less than 1mV/mA (See Figure 9)
- Pin Compatible to HC405X and MC1405XB Devices
- Power Supply Range ($V_{CC} - GND$) = 2.0 to 6.0 V
- In Compliance With the Requirements of JEDEC Standard No. 7A
- Chip Complexity: 154 FETs or 36 Equivalent Gates



ON Semiconductor

<http://onsemi.com>

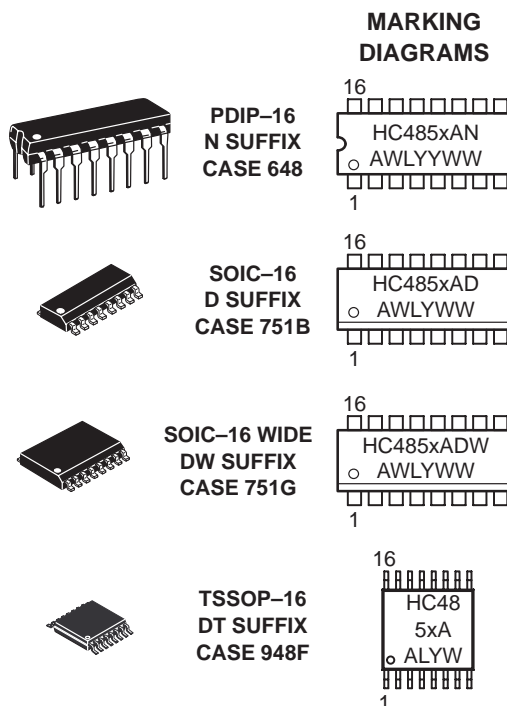

A = Assembly Location
 WL or L = Wafer Lot
 YY or Y = Year
 WW or W = Work Week

ORDERING INFORMATION

See detailed ordering and shipping information in the package dimensions section on page 10 of this data sheet.

MC74HC4851A, MC74HC4852A

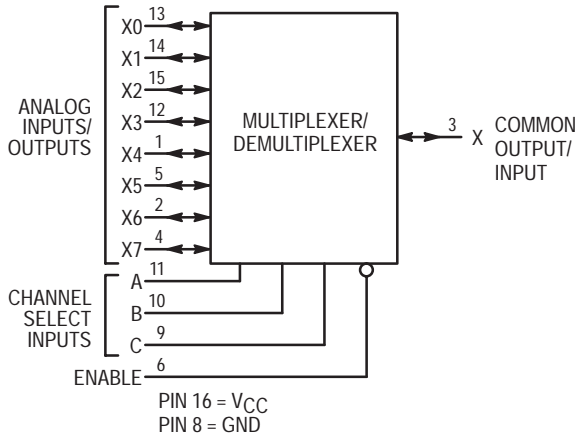

Figure 1. MC74HC4851A Logic Diagram Single-Pole, 8-Position Plus Common Off

FUNCTION TABLE – MC74HC4851A

Control Inputs					ON Channels
Enable	Select				
	C	B	A		
L	L	L	L	X0	
L	L	L	H	X1	
L	L	H	L	X2	
L	L	H	H	X3	
L	H	L	L	X4	
L	H	L	H	X5	
L	H	H	L	X6	
L	H	H	H	X7	
H	X	X	X	NONE	

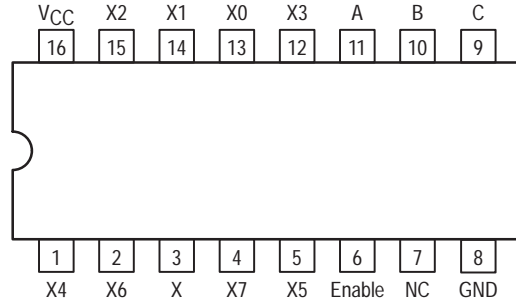

Figure 2. MC74HC4851A 16-Lead Pinout (Top View)

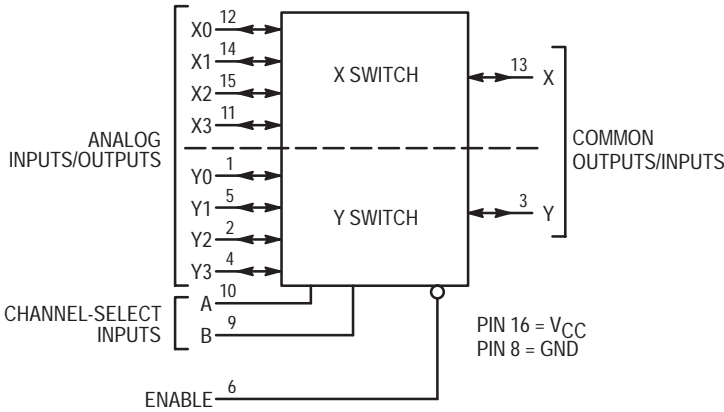

Figure 3. MC74HC4852A Logic Diagram Double-Pole, 4-Position Plus Common Off

FUNCTION TABLE – MC74HC4852A

Control Inputs				ON Channels
Enable	Select			
	B	A		
L	L	L	Y0 X0	
L	L	H	Y1 X1	
L	H	L	Y2 X2	
L	H	H	Y3 X3	
H	X	X	NONE	

X = Don't Care

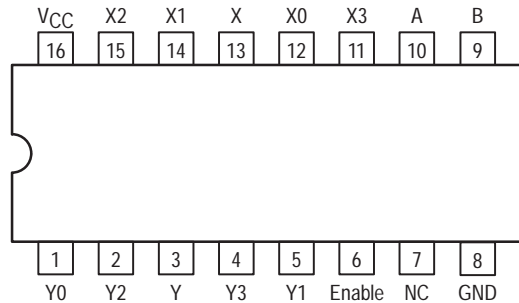

Figure 4. MC74HC4852A 16-Lead Pinout (Top View)

MC74HC4851A, MC74HC4852A

MAXIMUM RATINGS*

Symbol	Parameter	Value	Unit
V _{CC}	Positive DC Supply Voltage (Referenced to GND)	- 0.5 to + 7.0	V
V _{in}	DC Input Voltage (Any Pin) (Referenced to GND)	- 0.5 to V _{CC} + 0.5	V
I	DC Current, Into or Out of Any Pin	± 25	mA
P _D	Power Dissipation in Still Air, Plastic DIP† SOIC Package† TSSOP Package†	750 500 450	mW
T _{stg}	Storage Temperature Range	- 65 to + 150	°C
T _L	Lead Temperature, 1 mm from Case for 10 Seconds Plastic DIP, SOIC or TSSOP Package	260	°C

This device contains protection circuitry to guard against damage due to high static voltages or electric fields. However, precautions must be taken to avoid applications of any voltage higher than maximum rated voltages to this high-impedance circuit. For proper operation, V_{in} and V_{out} should be constrained to the range GND ≤ (V_{in} or V_{out}) ≤ V_{CC}. Unused inputs must always be tied to an appropriate logic voltage level (e.g., either GND or V_{CC}). Unused outputs must be left open.

*Maximum Ratings are those values beyond which damage to the device may occur.

Functional operation should be restricted to the Recommended Operating Conditions.

†Derating — Plastic DIP: - 10 mW/°C from 65° to 125°C

SOIC Package: - 7 mW/°C from 65° to 125°C

TSSOP Package: - 6.1 mW/°C from 65° to 125°C

For high frequency or heavy load considerations, see Chapter 2 of the ON Semiconductor High-Speed CMOS Data Book (DL129/D).

RECOMMENDED OPERATING CONDITIONS

Symbol	Parameter	Min	Max	Unit
V _{CC}	Positive DC Supply Voltage (Referenced to GND)	2.0	6.0	V
V _{in}	DC Input Voltage (Any Pin) (Referenced to GND)	GND	V _{CC}	V
V _{IO} *	Static or Dynamic Voltage Across Switch	0.0	1.2	V
T _A	Operating Temperature Range, All Package Types	- 55	+ 125	°C
t _r , t _f	Input Rise/Fall Time (Channel Select or Enable Inputs)	V _{CC} = 2.0 V 0 V _{CC} = 4.5 V 0 V _{CC} = 6.0 V 0	1000 500 400	ns

*For voltage drops across switch greater than 1.2V (switch on), excessive V_{CC} current may be drawn; i.e., the current out of the switch may contain both V_{CC} and switch input components. The reliability of the device will be unaffected unless the Maximum Ratings are exceeded.

DC CHARACTERISTICS — Digital Section (Voltages Referenced to GND) V_{EE} = GND, Except Where Noted

Symbol	Parameter	Condition	V _{CC} V	Guaranteed Limit			Unit
				-55 to 25°C	≤85°C	≤125°C	
V _{IH}	Minimum High-Level Input Voltage, Channel-Select or Enable Inputs	R _{on} = Per Spec	2.0	1.50	1.50	1.50	V
			3.0	2.10	2.10	2.10	
			4.5	3.15	3.15	3.15	
			6.0	4.20	4.20	4.20	
V _{IL}	Maximum Low-Level Input Voltage, Channel-Select or Enable Inputs	R _{on} = Per Spec	2.0	0.50	0.50	0.50	V
			3.0	0.90	0.90	0.90	
			4.5	1.35	1.35	1.35	
			6.0	1.80	1.80	1.80	
I _{in}	Maximum Input Leakage Current on Digital Pins (Enable/A/B/C)	V _{in} = V _{CC} or GND	6.0	± 0.1	± 1.0	± 1.0	µA
I _{CC}	Maximum Quiescent Supply Current (per Package)	V _{in(digital)} = V _{CC} or GND V _{in(analog)} = GND	6.0	2	20	40	µA

NOTE: Information on typical parametric values can be found in Chapter 2 of the ON Semiconductor High-Speed CMOS Data Book (DL129/D).

MC74HC4851A, MC74HC4852A

DC CHARACTERISTICS — Analog Section

Symbol	Parameter	Condition	VCC	Guaranteed Limit			Unit
				-55 to 25°C	≤85°C	≤125°C	
R _{on}	Maximum "ON" Resistance	V _{in} = V _{IL} or V _{IH} ; V _{IS} = V _{CC} to GND; I _S ≤ 2.0 mA	2.0	1700	1750	1800	Ω
			3.0	1100	1200	1300	
			4.5	550	650	750	
			6.0	400	500	600	
ΔR _{on}	Delta "ON" Resistance	V _{in} = V _{IL} or V _{IH} ; V _{IS} = V _{CC} /2 I _S ≤ 2.0 mA	2.0	300	400	500	Ω
			3.0	160	200	240	
			4.5	80	100	120	
			6.0	60	80	100	
I _{off}	Maximum Off-Channel Leakage Current, Any One Channel Common Channel	V _{in} = V _{CC} or GND	6.0	±0.1	±0.5	±1.0	μA
				±0.2	±2.0	±4.0	
I _{on}	Maximum On-Channel Leakage Channel-to-Channel	V _{in} = V _{CC} or GND	6.0	±0.2	±2.0	±4.0	μA

AC CHARACTERISTICS (C_L = 50 pF, Input t_r = t_f = 6 ns)

Symbol	Parameter	VCC	-55 to 25°C	≤85°C	≤125°C	Unit
t _{PHL} , t _{PLH}	Maximum Propagation Delay, Analog Input to Analog Output	2.0	160	180	200	ns
		3.0	80	90	100	
		4.5	40	45	50	
		6.0	30	35	40	
t _{PHL} , t _{PHZ} , PZH t _{PLH} , t _{PLZ} , PZL	Maximum Propagation Delay, Enable or Channel-Select to Analog Output	2.0	260	280	300	ns
		3.0	160	180	200	
		4.5	80	90	100	
		6.0	60	70	80	
C _{in}	Maximum Input Capacitance (All Switches Off) (All Switches Off)	Digital Pins Any Single Analog Pin Common Analog Pin	10	10	10	pF
			35	35	35	
			130	130	130	
C _{PD}	Power Dissipation Capacitance	Typical	5.0	20		pF

INJECTION CURRENT COUPLING SPECIFICATIONS (V_{CC} = 5V, T_A = -55°C to +125°C)

Symbol	Parameter	Typ	Max	Unit	Condition
V _{Δout}	Maximum Shift of Output Voltage of Enabled Analog Channel	0.1 1.0 0.5 5.0	1.0 5.0 2.0 20	mV	I _{in} * ≤ 1mA, R _S ≤ 3,9kΩ I _{in} * ≤ 10mA, R _S ≤ 3,9kΩ I _{in} * ≤ 1mA, R _S ≤ 20kΩ I _{in} * ≤ 10mA, R _S ≤ 20kΩ

* I_{in} = Total current injected into all disabled channels.

MC74HC4851A, MC74HC4852A

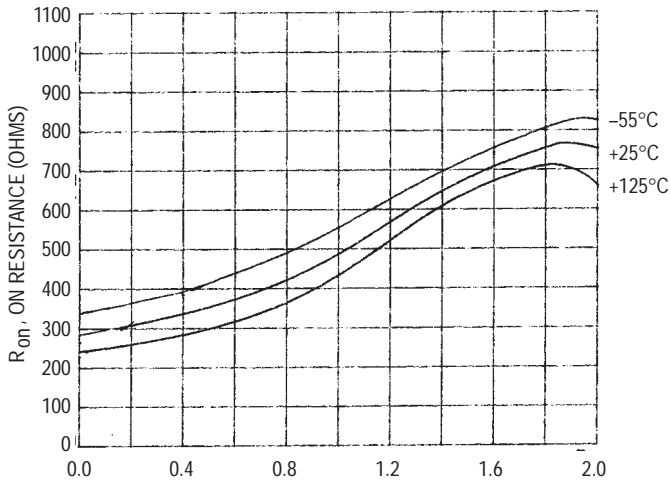

V_{in}, INPUT VOLTAGE (VOLTS), REFERENCED TO GND
Figure 5. Typical On Resistance V_{CC} = 2V

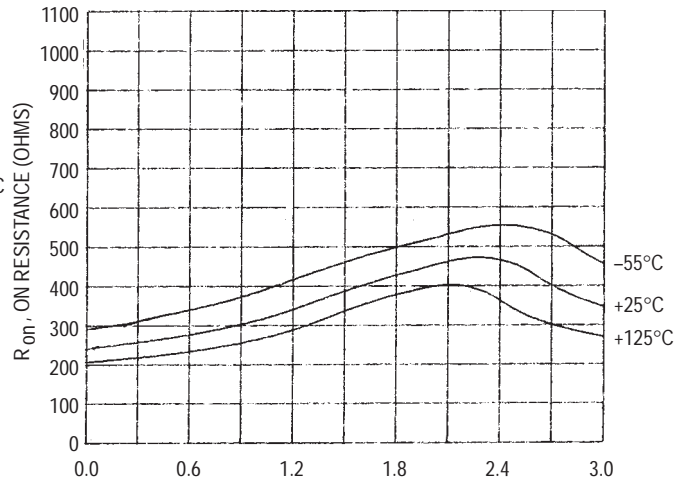

V_{in}, INPUT VOLTAGE (VOLTS), REFERENCED TO GND
Figure 6. Typical On Resistance V_{CC} = 3V

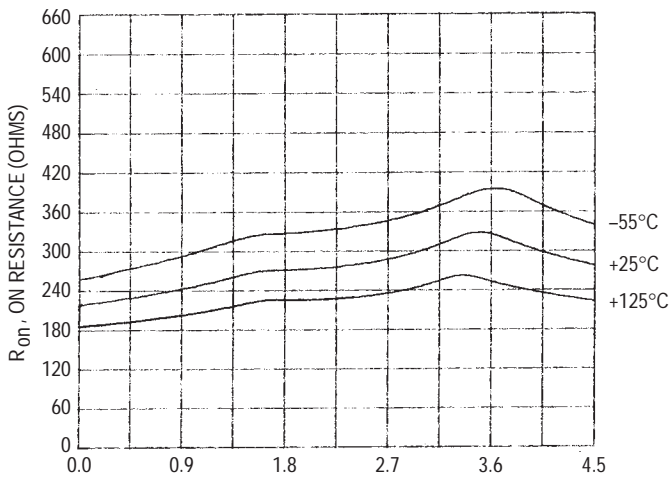

V_{in}, INPUT VOLTAGE (VOLTS), REFERENCED TO GND
Figure 7. Typical On Resistance V_{CC} = 4.5V

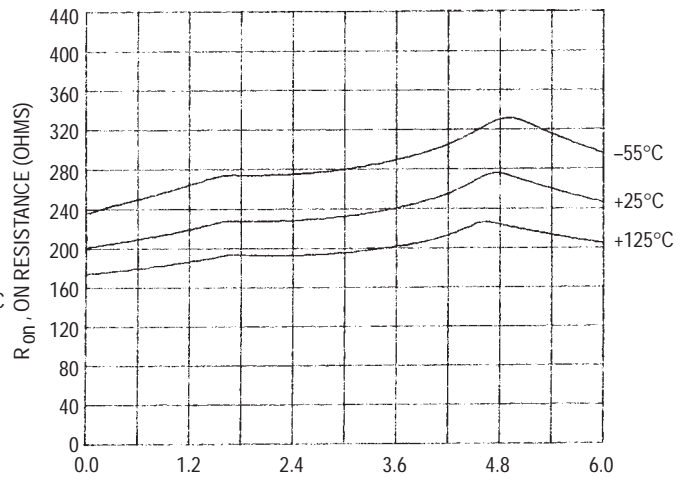

V_{in}, INPUT VOLTAGE (VOLTS), REFERENCED TO GND
Figure 8. Typical On Resistance V_{CC} = 6V

MC74HC4851A, MC74HC4852A

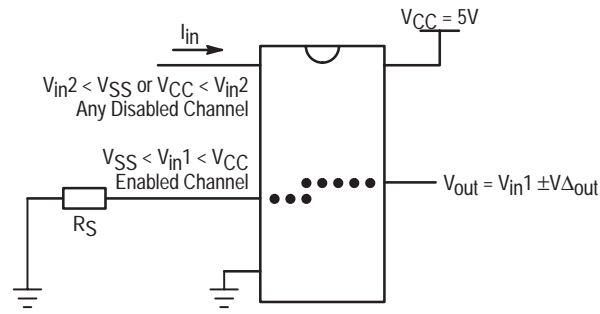

Figure 9. Injection Current Coupling Specification

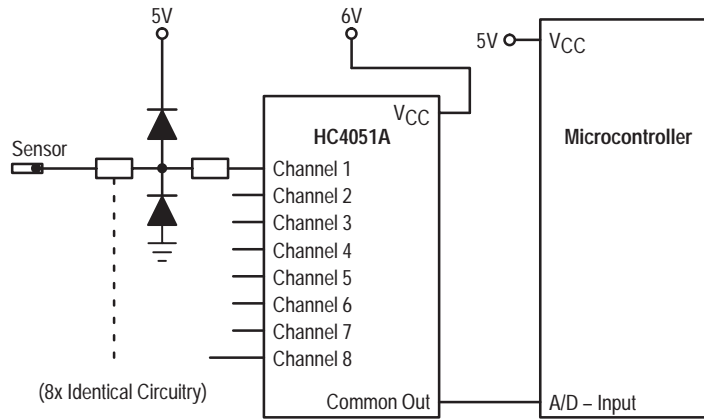

Figure 10. Actual Technology

Requires 32 passive components and one extra 6V regulator to suppress injection current into a standard HC4051 multiplexer

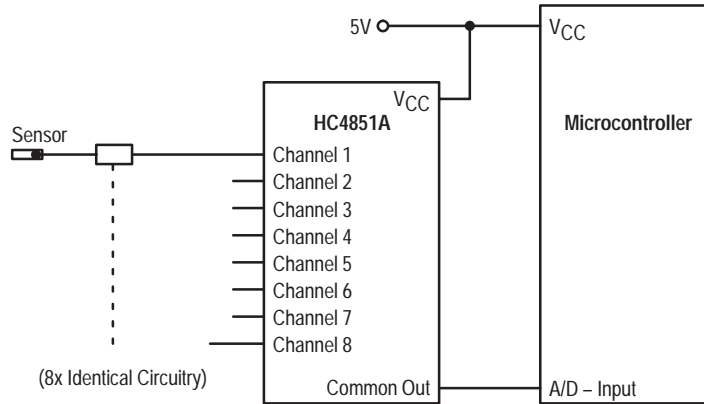

Figure 11. MC74HC4851A Solution

Solution by applying the HC4851A multiplexer

MC74HC4851A, MC74HC4852A

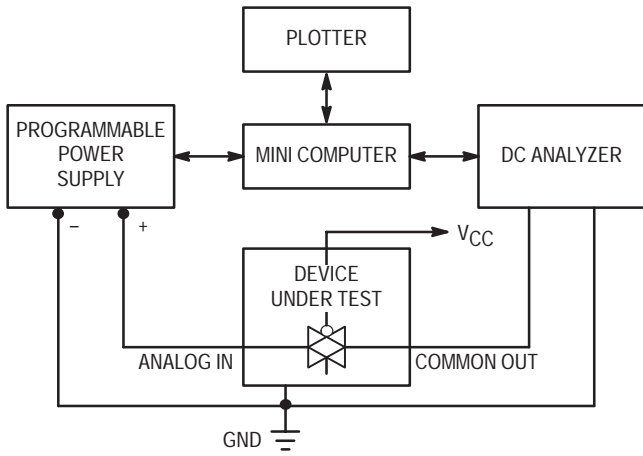

Figure 12. On Resistance Test Set-Up

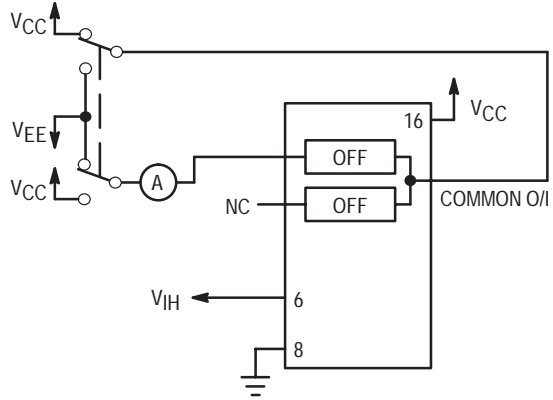

Figure 13. Maximum Off Channel Leakage Current, Any One Channel, Test Set-Up

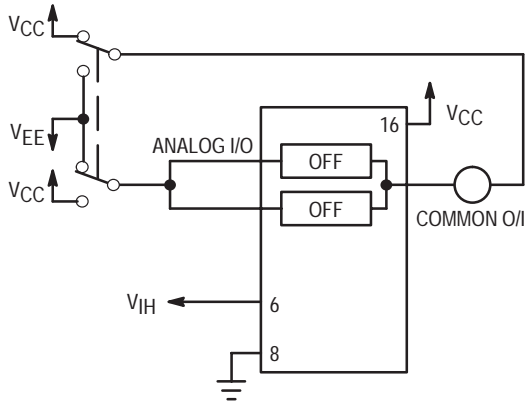

Figure 14. Maximum Off Channel Leakage Current, Common Channel, Test Set-Up

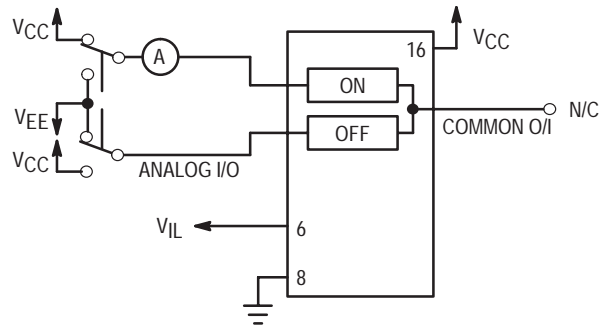

Figure 15. Maximum On Channel Leakage Current, Channel to Channel, Test Set-Up

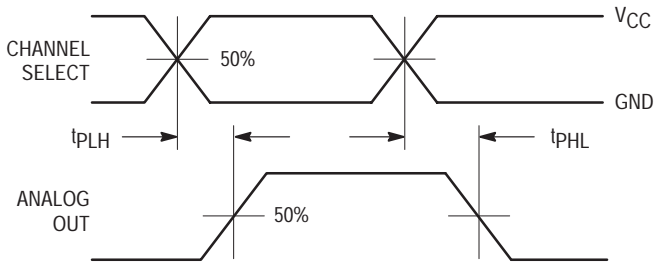
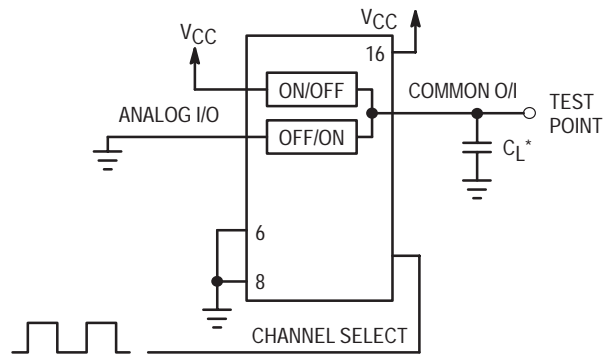

Figure 16. Propagation Delays, Channel Select to Analog Out



*Includes all probe and jig capacitance

Figure 17. Propagation Delay, Test Set-Up Channel Select to Analog Out

MC74HC4851A, MC74HC4852A

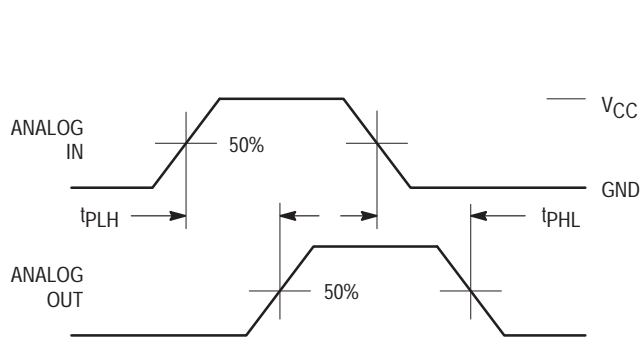
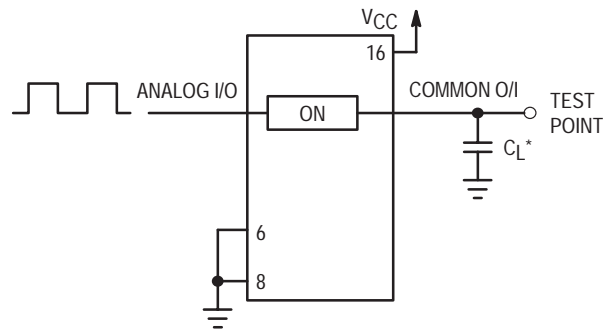

Figure 18. Propagation Delays, Analog In to Analog Out



*Includes all probe and jig capacitance

Figure 19. Propagation Delay, Test Set-Up Analog In to Analog Out

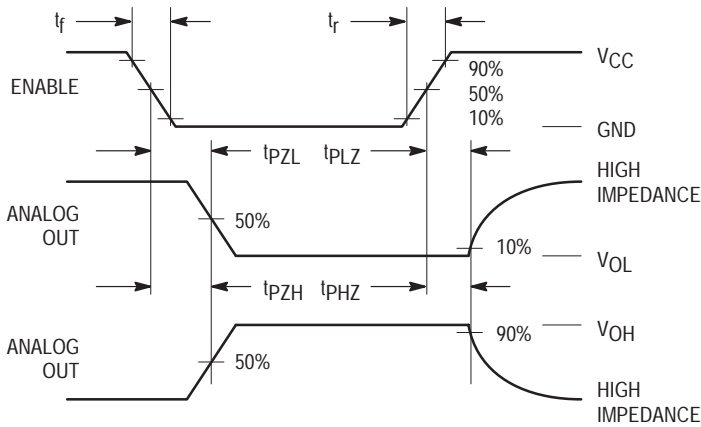

Figure 20. Propagation Delays, Enable to Analog Out

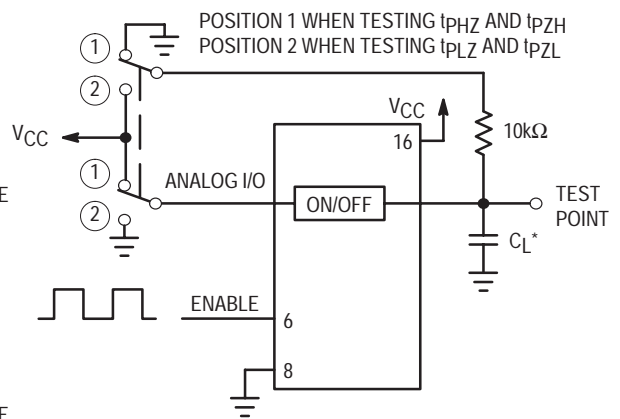

Figure 21. Propagation Delay, Test Set-Up Enable to Analog Out

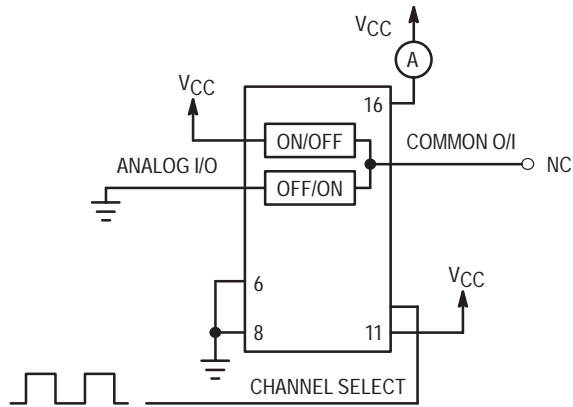

Figure 22. Power Dissipation Capacitance, Test Set-Up

MC74HC4851A, MC74HC4852A

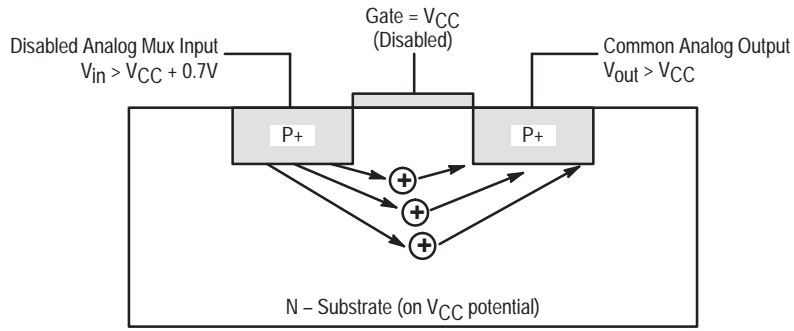

Figure 23. Diagram of Bipolar Coupling Mechanism
Appears if V_{in} exceeds V_{CC} , driving injection current into the substrate

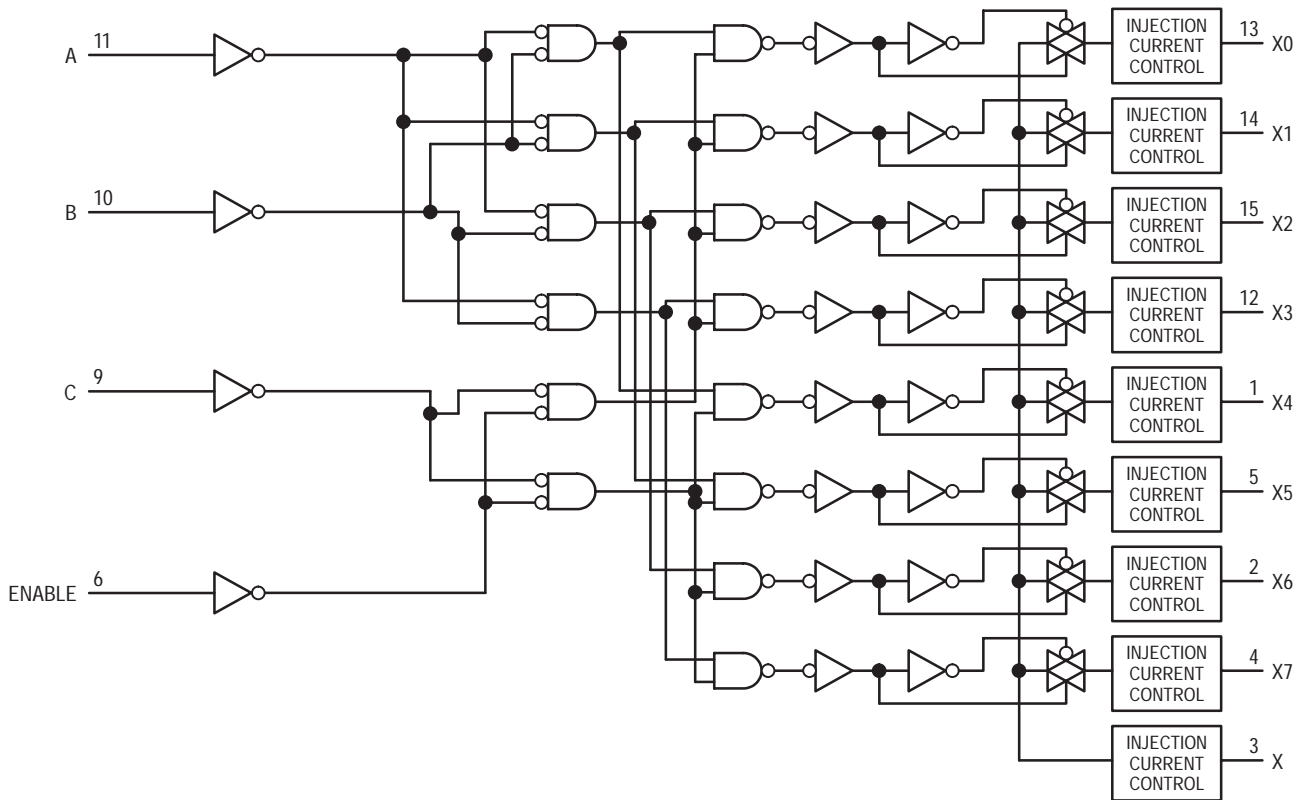

Figure 24. Function Diagram, HC4851A

MC74HC4851A, MC74HC4852A

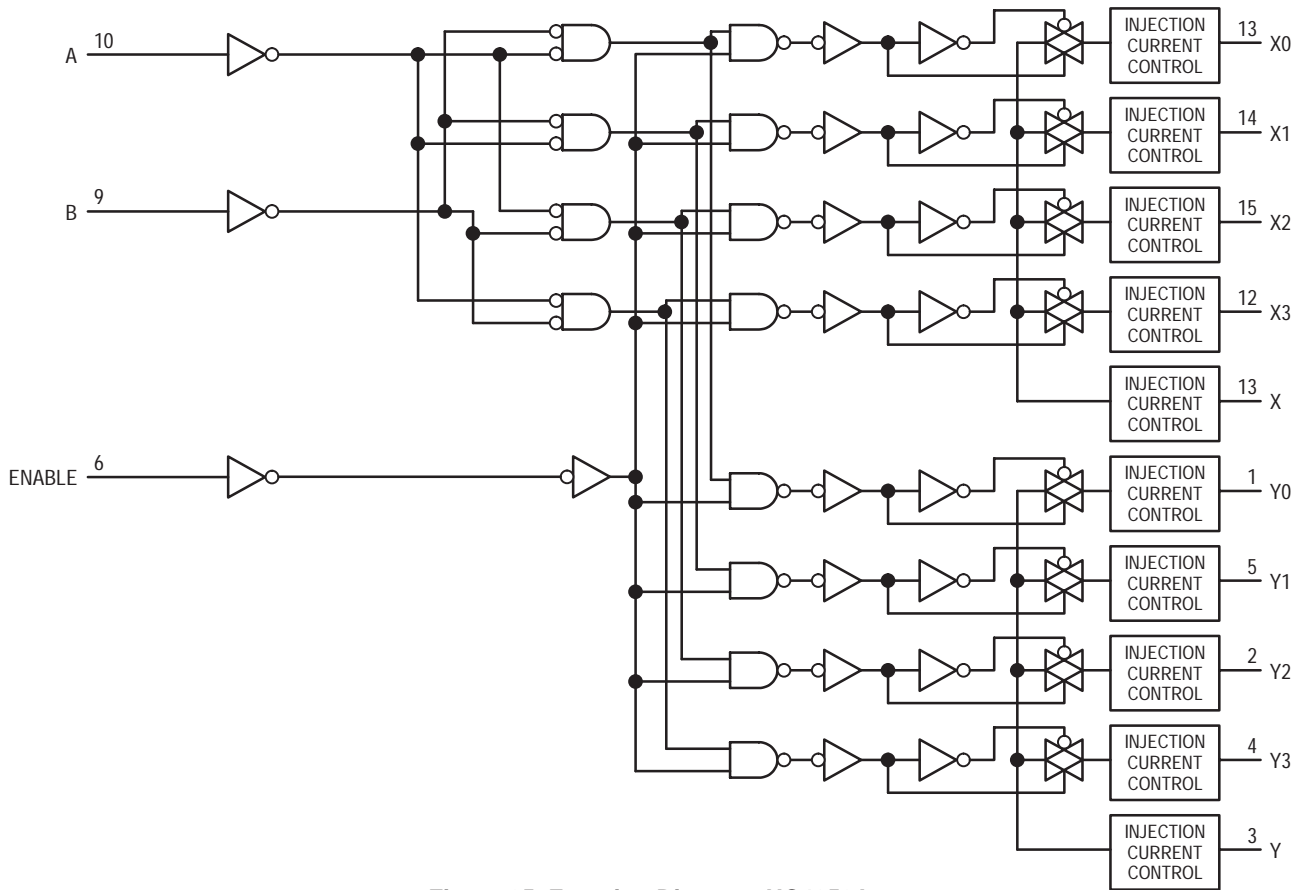

Figure 25. Function Diagram, HC4852A

ORDERING & SHIPPING INFORMATION

Device	Package	Shipping
MC74HC4851AN	PDIP-16	500 Units / Unit Pak
MC74HC4851AD	SOIC-16	48 Units / Rail
MC74HC4851ADR2	SOIC-16	2500 Units / Tape & Reel
MC74HC4851ADW	SOIC-16 WIDE	48 Units / Rail
MC74HC4851ADWR2	SOIC-16 WIDE	1000 Units / Tape & Reel
MC74HC4851ADT	TSSOP-16	96 Units / Rail
MC74HC4851ADTR2	TSSOP-16	2500 Units / Tape & Reel
MC74HC4852AN	PDIP-16	500 Units / Unit Pak
MC74HC4852AD	SOIC-16	48 Units / Rail
MC74HC4852ADR2	SOIC-16	2500 Units / Tape & Reel
MC74HC4852ADW	SOIC-16 WIDE	48 Units / Rail
MC74HC4852ADWR2	SOIC-16 WIDE	1000 Units / Tape & Reel
MC74HC4852ADT	TSSOP-16	96 Units / Rail
MC74HC4852ADTR2	TSSOP-16	2500 Units / Tape & Reel

MC74HC4851A, MC74HC4852A

PACKAGE DIMENSIONS

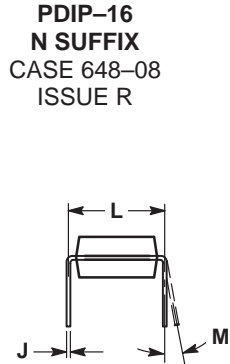
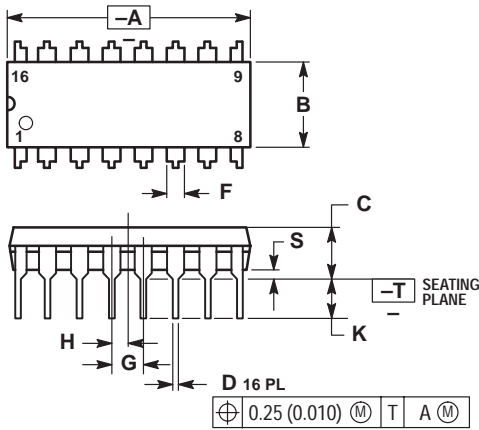

NOTES:

1. DIMENSIONING AND TOLERANCING PER ANSI Y14.5M, 1982.
2. CONTROLLING DIMENSION: INCH.
3. DIMENSION L TO CENTER OF LEADS WHEN FORMED PARALLEL.
4. DIMENSION B DOES NOT INCLUDE MOLD FLASH.
5. ROUNDED CORNERS OPTIONAL.

DIM	INCHES		MILLIMETERS	
	MIN	MAX	MIN	MAX
A	0.740	0.770	18.80	19.55
B	0.250	0.270	6.35	6.85
C	0.145	0.175	3.69	4.44
D	0.015	0.021	0.39	0.53
F	0.040	0.070	1.02	1.77
G	0.100 BSC		2.54 BSC	
H	0.050 BSC		1.27 BSC	
J	0.008	0.015	0.21	0.38
K	0.110	0.130	2.80	3.30
L	0.295	0.305	7.50	7.74
M	0°	10°	0°	10°
S	0.020	0.040	0.51	1.01

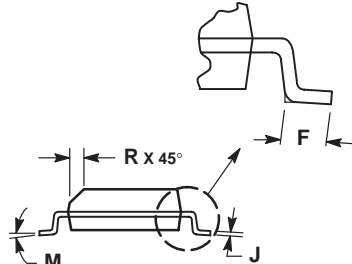
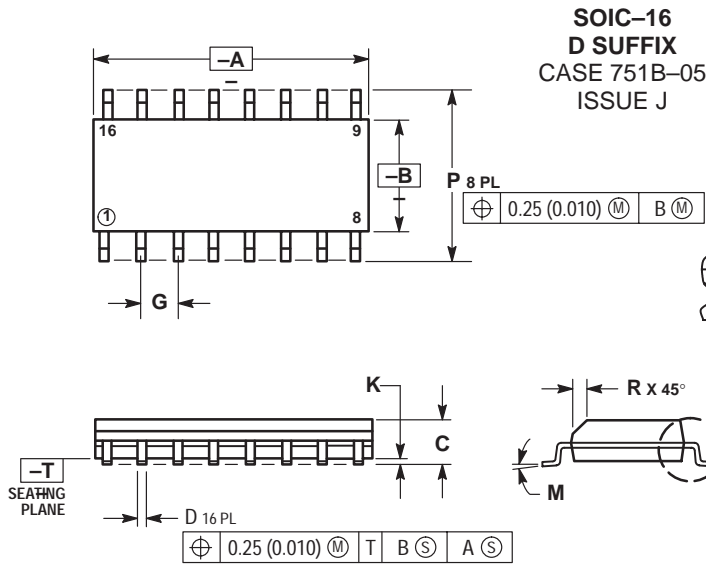

NOTES:

1. DIMENSIONING AND TOLERANCING PER ANSI Y14.5M, 1982.
2. CONTROLLING DIMENSION: MILLIMETER.
3. DIMENSIONS A AND B DO NOT INCLUDE MOLD PROTRUSION.
4. MAXIMUM MOLD PROTRUSION 0.15 (0.006) PER SIDE.
5. DIMENSION D DOES NOT INCLUDE DAMBAR PROTRUSION. ALLOWABLE DAMBAR PROTRUSION SHALL BE 0.127 (0.005) TOTAL IN EXCESS OF THE D DIMENSION AT MAXIMUM MATERIAL CONDITION.

DIM	MILLIMETERS		INCHES	
	MIN	MAX	MIN	MAX
A	9.80	10.00	0.386	0.393
B	3.80	4.00	0.150	0.157
C	1.35	1.75	0.054	0.068
D	0.35	0.49	0.014	0.019
F	0.40	1.25	0.016	0.049
G	1.27 BSC		0.050 BSC	
J	0.19	0.25	0.008	0.009
K	0.10	0.25	0.004	0.009
M	0°	7°	0°	7°
P	5.80	6.20	0.229	0.244
R	0.25	0.50	0.010	0.019

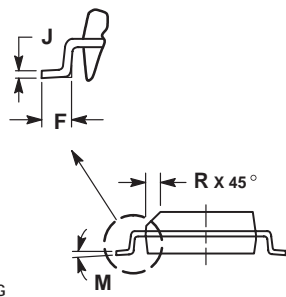
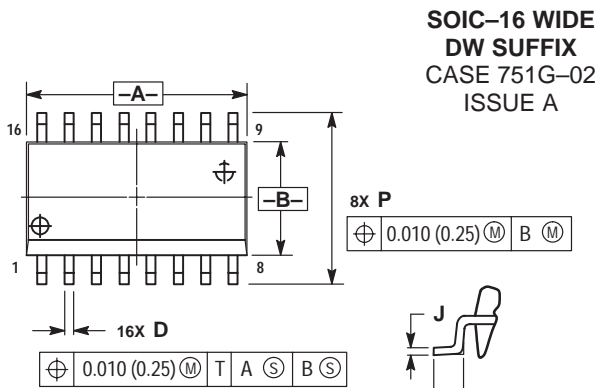

NOTES:

1. DIMENSIONING AND TOLERANCING PER ANSI Y14.5M, 1982.
2. CONTROLLING DIMENSION: MILLIMETER.
3. DIMENSIONS A AND B DO NOT INCLUDE MOLD PROTRUSION.
4. MAXIMUM MOLD PROTRUSION 0.15 (0.006) PER SIDE.
5. DIMENSION D DOES NOT INCLUDE DAMBAR PROTRUSION. ALLOWABLE DAMBAR PROTRUSION SHALL BE 0.13 (0.005) TOTAL IN EXCESS OF D DIMENSION AT MAXIMUM MATERIAL CONDITION.

DIM	MILLIMETERS		INCHES	
	MIN	MAX	MIN	MAX
A	10.15	10.45	0.400	0.411
B	7.40	7.60	0.292	0.299
C	2.35	2.65	0.093	0.104
D	0.35	0.49	0.014	0.019
F	0.50	0.90	0.020	0.035
G	1.27 BSC		0.050 BSC	
J	0.25	0.32	0.010	0.012
K	0.10	0.25	0.004	0.009
M	0°	7°	0°	7°
P	10.05	10.55	0.395	0.415
R	0.25	0.75	0.010	0.029

MC74HC4851A, MC74HC4852A

PACKAGE DIMENSIONS

TSSOP-16
DT SUFFIX
CASE 948F-01
ISSUE O

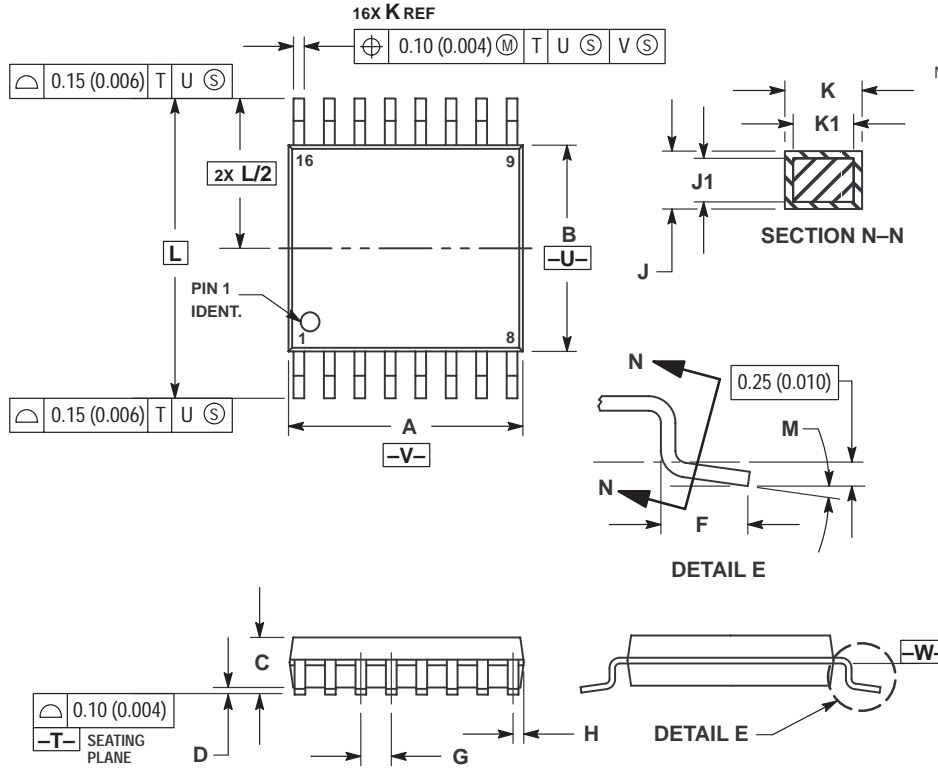

NOTES:

- DIMENSIONING AND TOLERANCING PER ANSI Y14.5M, 1982.
- CONTROLLING DIMENSION: MILLIMETER.
- DIMENSION A DOES NOT INCLUDE MOLD FLASH, PROTRUSIONS OR GATE BURRS. MOLD FLASH OR GATE BURRS SHALL NOT EXCEED 0.15 (0.006) PER SIDE.
- DIMENSION B DOES NOT INCLUDE INTERLEAD FLASH OR PROTRUSION. INTERLEAD FLASH OR PROTRUSION SHALL NOT EXCEED 0.25 (0.010) PER SIDE.
- DIMENSION K DOES NOT INCLUDE DAMBAR PROTRUSION. ALLOWABLE DAMBAR PROTRUSION SHALL BE 0.08 (0.003) TOTAL IN EXCESS OF THE K DIMENSION AT MAXIMUM MATERIAL CONDITION.
- TERMINAL NUMBERS ARE SHOWN FOR REFERENCE ONLY.
- DIMENSION A AND B ARE TO BE DETERMINED AT DATUM PLANE -W-.

DIM	MILLIMETERS		INCHES	
	MIN	MAX	MIN	MAX
A	4.90	5.10	0.193	0.200
B	4.30	4.50	0.169	0.177
C	—	1.20	—	0.047
D	0.05	0.15	0.002	0.006
F	0.50	0.75	0.020	0.030
G	0.65 BSC	—	0.026 BSC	—
H	0.18	0.28	0.007	0.011
J	0.09	0.20	0.004	0.008
J1	0.09	0.16	0.004	0.006
K	0.19	0.30	0.007	0.012
K1	0.19	0.25	0.007	0.010
L	6.40 BSC	—	0.252 BSC	—
M	0°	8°	0°	8°

ON Semiconductor and are trademarks of Semiconductor Components Industries, LLC (SCILLC). SCILLC reserves the right to make changes without further notice to any products herein. SCILLC makes no warranty, representation or guarantee regarding the suitability of its products for any particular purpose, nor does SCILLC assume any liability arising out of the application or use of any product or circuit, and specifically disclaims any and all liability, including without limitation special, consequential or incidental damages. "Typical" parameters which may be provided in SCILLC data sheets and/or specifications can and do vary in different applications and actual performance may vary over time. All operating parameters, including "Typicals" must be validated for each customer application by customer's technical experts. SCILLC does not convey any license under its patent rights nor the rights of others. SCILLC products are not designed, intended, or authorized for use as components in systems intended for surgical implant into the body, or other applications intended to support or sustain life, or for any other application in which the failure of the SCILLC product could create a situation where personal injury or death may occur. Should Buyer purchase or use SCILLC products for any such unintended or unauthorized application, Buyer shall indemnify and hold SCILLC and its officers, employees, subsidiaries, affiliates, and distributors harmless against all claims, costs, damages, and expenses, and reasonable attorney fees arising out of, directly or indirectly, any claim of personal injury or death associated with such unintended or unauthorized use, even if such claim alleges that SCILLC was negligent regarding the design or manufacture of the part. SCILLC is an Equal Opportunity/Affirmative Action Employer.

PUBLICATION ORDERING INFORMATION

NORTH AMERICA Literature Fulfillment:

Literature Distribution Center for ON Semiconductor
P.O. Box 5163, Denver, Colorado 80217 USA
Phone: 303-675-2175 or 800-344-3860 Toll Free USA/Canada
Fax: 303-675-2176 or 800-344-3867 Toll Free USA/Canada
Email: ONlit@hibbertco.com
Fax Response Line: 303-675-2167 or 800-344-3810 Toll Free USA/Canada

N. American Technical Support: 800-282-9855 Toll Free USA/Canada

EUROPE: LDC for ON Semiconductor – European Support

German Phone: (+1) 303-308-7140 (M-F 1:00pm to 5:00pm Munich Time)
Email: ONlit-german@hibbertco.com
French Phone: (+1) 303-308-7141 (M-F 1:00pm to 5:00pm Toulouse Time)
Email: ONlit-french@hibbertco.com
English Phone: (+1) 303-308-7142 (M-F 12:00pm to 5:00pm UK Time)
Email: ONlit@hibbertco.com

EUROPEAN TOLL-FREE ACCESS*: 00-800-4422-3781

*Available from Germany, France, Italy, England, Ireland

CENTRAL/SOUTH AMERICA:

Spanish Phone: 303-308-7143 (Mon-Fri 8:00am to 5:00pm MST)
Email: ONlit-spanish@hibbertco.com

ASIA/PACIFIC: LDC for ON Semiconductor – Asia Support

Phone: 303-675-2121 (Tue-Fri 9:00am to 1:00pm, Hong Kong Time)
Toll Free from Hong Kong & Singapore:
001-800-4422-3781
Email: ONlit-asia@hibbertco.com

JAPAN: ON Semiconductor, Japan Customer Focus Center

4-32-1 Nishi-Gotanda, Shinagawa-ku, Tokyo, Japan 141-8549
Phone: 81-3-5740-2745
Email: r14525@onsemi.com

ON Semiconductor Website: <http://onsemi.com>

For additional information, please contact your local Sales Representative.