

MEDIUM POWER AMPLIFIER GaAs MMIC

■GENERAL DESCRIPTION

NJG1304E is a GaAs MMIC designed mainly for driver amplifier of PHS base station in Japan.

This is a variable gain type with 20dB dynamic range. It features very low distortion and P_{ACP} is less than -70dBc . at 17dBm output power, and enable low voltage and high efficiency operation.

Small Plastic mold Package are adopted.

■PACKAGE OUTLINE



NJG1304E

■FEATURES

- Voltage gain under low distortion
- Low voltage operation
- Low current consumption
- High gain
- Low distortion(ACP)
- Power Dissipation
- Reduction of Parasitic oscillation
- Input and output internal matching circuit
- Package

$V_{DD} = +3.0\text{V}$ typ.

$I_{DD} = 180\text{mA}$ typ. @ $f = 1.9\text{GHz}$, $P_{out} = 17\text{dBm}$

Gain = 32dB

$P_{ACP} = -70\text{dBc}$ typ. @ $f = 1.9\text{GHz}$, $P_{OUT} = 17\text{dBm}$
1000mW

EMP14

■PIN CONFIGURATION

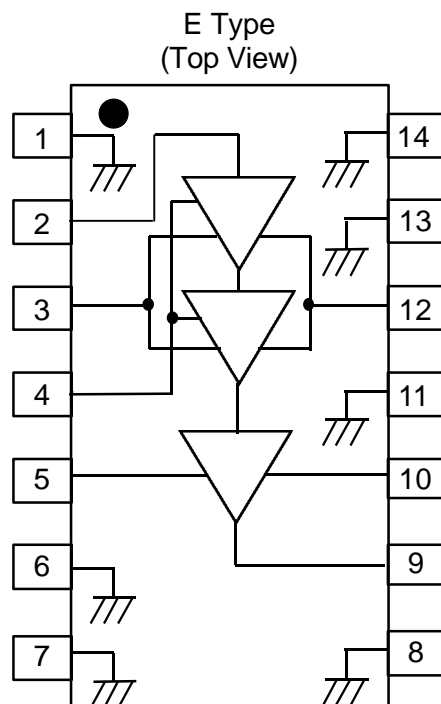

Pin Connection

- 1.GND
- 2.RF_{in}
- 3.V_{GG1}
- 4.V_{CONT}
- 5.V_{GG2}
- 6.GND
- 7.GND
- 8.GND
- 9.RF_{OUT}
- 10.V_{DD2}
- 11.GND
- 12.V_{DD1}
- 13.GND
- 14.GND

NJG1304E

■ABSOLUTE MAXIMUM RATINGS

($T_a=+25^{\circ}\text{C}$, $Z_s=Z_l=50\Omega$)

PARAMETER	SYMBOL	CONDITIONS	RATINGS	UNITS
Drain Voltage	V_{DD1}, V_{DD2}	$V_{GG1}, V_{GG2}=-0.9\text{V}$	6.0	V
Gate Voltage	V_{GG1}, V_{GG2}	$V_{DD1}, V_{DD2}=-3.0\text{V}$	-4.0	V
Gain Control Voltage	V_{CONT}	$V_{DD1}, V_{DD2}=-3.0\text{V}$	-4.0	V
Input Power	P_{in}	$V_{DD1}, V_{DD2}=-3.0\text{V}$, $V_{GG1}, V_{GG2}=-0.9\text{V}$	3.0	dBm
Power Dissipation	P_D	At on PCB board	1000	mW
Operating Temperature	T_{opr}		-30 ~ +85	$^{\circ}\text{C}$
Storage Temperature	T_{stg}		-40 ~ +150	$^{\circ}\text{C}$

■ELECTRICAL CHARACTERISTICS

($T_a=+25^{\circ}\text{C}$, $Z_s=Z_l=50\Omega$)

PARAMETER	SYMBOL	CONDITONS	MIN	TYP	MAX	UNITS
Operating Frequency	freq	$V_{DD1,2}=3.0\text{V}$	1.89	-	1.92	GHz
Drain Voltage	$V_{DD1,2}$		2.9	3.0	5.3	V
Gate Voltage	$V_{GG1,2}$	$V_{DD1,2}=3.0\text{V}$, $I_{idle}=170\text{mA}$	-1.25	-0.9	-0.6	V
Idle Current *1	I_{idle}	$V_{DD1,2}=3.0\text{V}$, No RF Signal	175	180	185	mA
Operating Current *1	I_{DD}	$V_{DD1,2}=3.0\text{V}$, $P_{out}=21\text{dBm}$	180	195	205	mA
Gate Current *2	I_{GG}	$V_{DD1,2}=3.0\text{V}$, $P_{out}=21\text{dBm}$	-150	-70	-	μA
Gain Control Terminal Current	I_{CONT}	$V_{DD1,2}=3.0\text{V}$, $P_{out}=21\text{dBm}$ $-2.0 < V_{CONT} < 0.0\text{V}$	-5.0	-2.0	-	μA
Gain Control Voltage	V_{CONT}		-2.0	-	0	V
Small Signal Gain	Gain	$V_{DD1,2}=3.0\text{V}$, $I_{idle}=180\text{mA}$	29	32	35	dB
Gain Flatness	G_{flat}	$V_{DD1,2}=3.0\text{V}$, $I_{idle}=180\text{mA}$	0	0.5	1.0	dB
Gain Control Range	G_{CONT}	$V_{CONT}=-2\sim 0\text{V}$, $V_{DD1,2}=3.0\text{V}$ $I_{idle}=180\text{mA}$	18	20	23	dB
Pout at 1dB Compression point	P_{-1dB}	$V_{DD1,2}=3.0\text{V}$	22	23	-	dBm
Adjacent Channel Leakage Power 1	P_{acp1}	$V_{DD1,2}=3.0\text{V}$, $P_{out}=17\text{dBm}$ offset=600kHz $P_{in}; \pi/4$ DQPSK	-	-	-70	dBc
Adjacent Channel Leakage Power 2	P_{acp2}	$V_{DD1,2}=3.0\text{V}$, $P_{out}=17\text{dBm}$ offset=900kHz $P_{in}; \pi/4$ DQPSK	-	-	-70	dBc
Adjacent Channel Leakage Power 1	P_{acp1}	$V_{DD1,2}=3.0\text{V}$, $P_{out}=13\text{dBm}$ (Adjust V_{cont}), offset=600kHz $P_{in}=-7\text{dBm}$; $\pi/4$ DQPSK	-	-	-70	dBc
Adjacent Channel Leakage Power 2	P_{acp2}	$V_{DD1,2}=3.0\text{V}$, $P_{out}=21\text{dBm}$ (Adjust V_{cont}), offset=900kHz $P_{in}=-7\text{dBm}$; $\pi/4$ DQPSK	-	-	-70	dBc
Harmonics	P_{SP}	$V_{DD1,2}=3.0\text{V}$, $P_{out}=21\text{dBm}$	-	-35	-30	dBc
Input VSWR	$VSWR_i$	$V_{DD1,2}=3.0\text{V}$	-	-	2.2	
Load VSWR Tolerance	-	$V_{DD1,2}=3.0\text{V}$, $P_{out}=21\text{dBm}$ Load VSWR=4:1, All Phase	Parasitic Oscillation for Fundamental Signal Level : $\leq -60\text{dBc}$			

*1: V_{DD1} Terminal V_{DD2} Terminal Total Current

*2: V_{GG1} Terminal V_{GG2} Terminal Total Current

TYPICAL CHARACTERISTICS

Gain vs. Frequency vs. Control Voltage

$(V_{DD}=3.0V, I_{DD}=180mA, T_a=25^\circ C)$

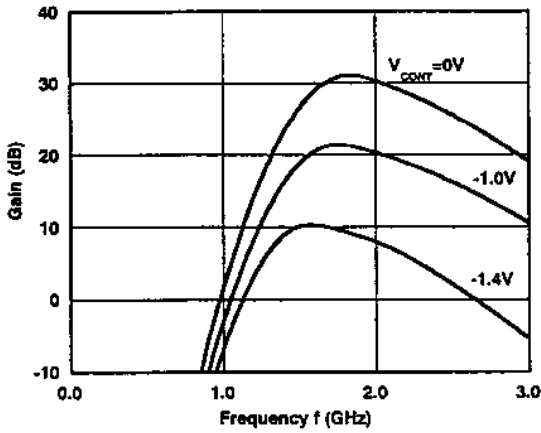

Gain vs PHS Band Frequency vs. Control Voltage

$(V_{DD}=3.0V, I_{DD}=180mA, T_a=25^\circ C)$

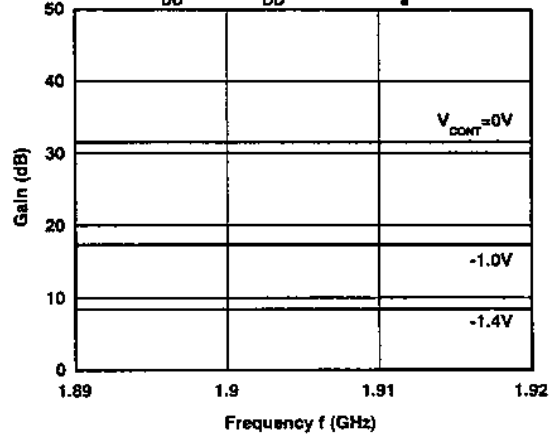

Output Power, Operating Current vs. Input Power

$(V_{DD}=3.0V, V_{CONT}=0V, I_{idle}=180mA, f=1.9GHz, T_a=25^\circ C)$

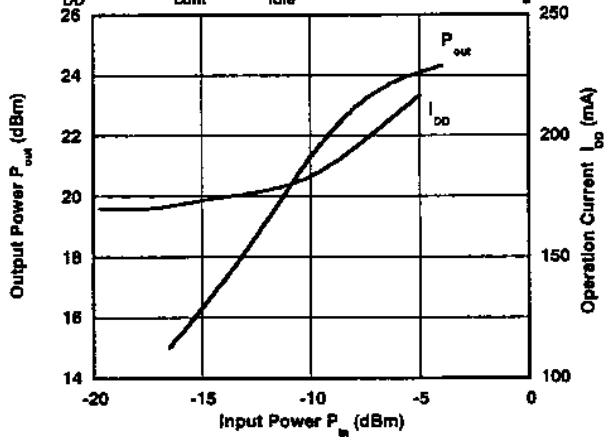

Output Power vs. Input Power vs. Control Voltage

$(V_{DD}=3.0V, I_{idle}=180mA, f=1.9GHz, T_a=25^\circ C)$

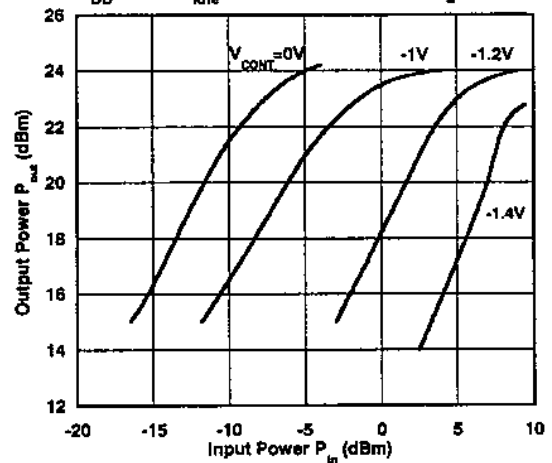

Output Power, Gate Current vs. Input Power

$(V_{DD}=3.0V, V_{CONT}=0V, I_{idle}=180mA, f=1.9GHz, T_a=25^\circ C)$

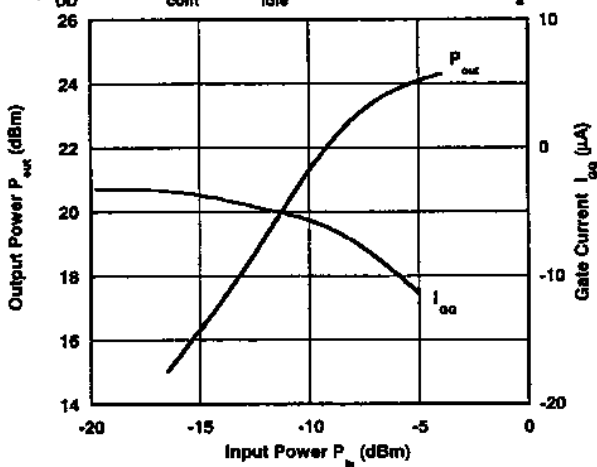

P_{acc} vs. Input Power vs. Control Voltage

$(V_{DD}=3.0V, I_{idle}=180mA, f=1.9GHz, T_a=25^\circ C)$

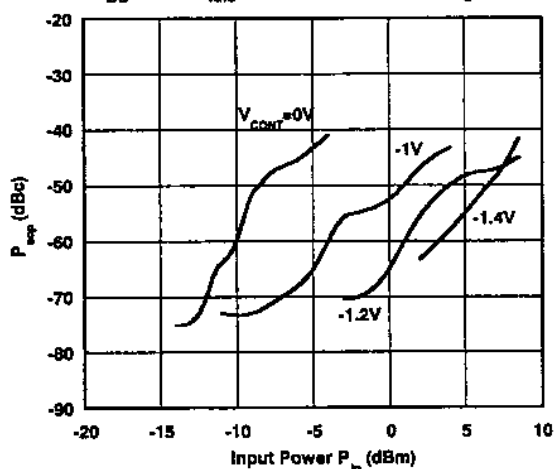

NJG1304E

TYPICAL CHARACTERISTICS

Output Power, P_{acp} vs. Control Voltage

($V_{DD}=3.0V, I_{idle}=180mA, f=1.9GHz, P_{in}=-11dBm, T_a=25^\circ C$)

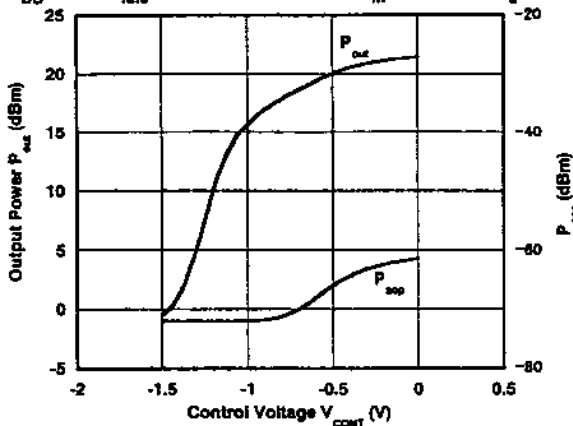

P_{acp} vs. Operating Current vs. V_{DD}

($P_{out}=17dBm, V_{cont}=0V, f=1.9GHz, T_a=25^\circ C$)

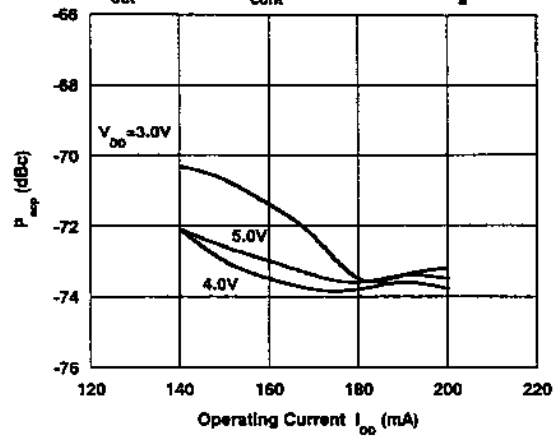

Operating Current, P_{acp} vs. Control Voltage

($V_{DD}=3.0V, I_{idle}=180mA, f=1.9GHz, P_{in}=-11dBm, T_a=25^\circ C$)

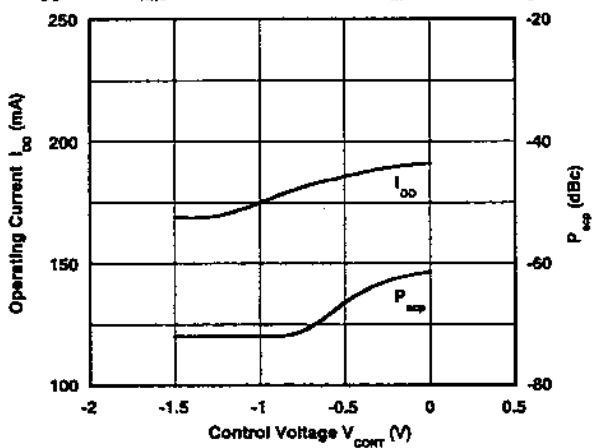

P_{acp} vs. Operating Current vs. V_{DD}

($P_{out}=13dBm, P_{in}=-7dBm, V_{cont}=-1.1V, f=1.9GHz, T_a=25^\circ C$)

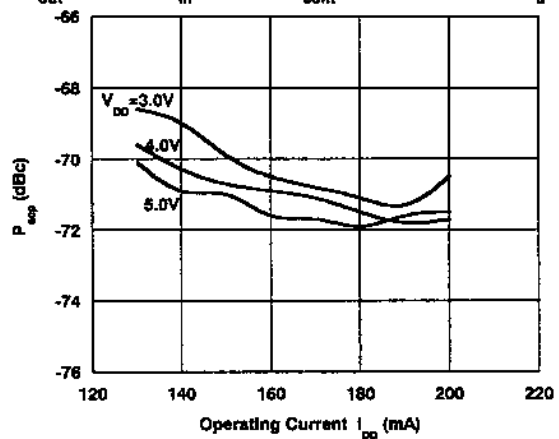

Gain, P_{acp} vs. Ambient Temperature

($V_{DD}=3.0V, V_{cont}=0V, I_{idle}=180mA, P_{out}=21dBm, f=1.9GHz$)

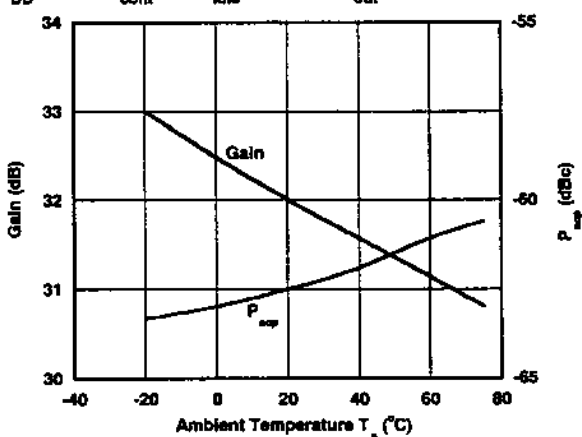

Operating Current vs. Ambient Temperature

($V_{DD}=3.0V, V_{cont}=0V, I_{idle}=180mA, P_{out}=21dBm, f=1.9GHz$)

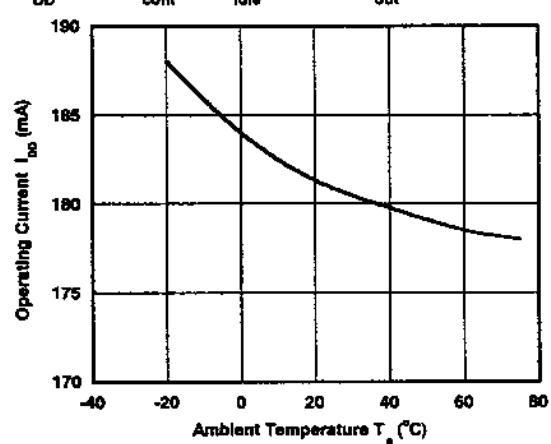

TYPICAL CHARACTERISTICS

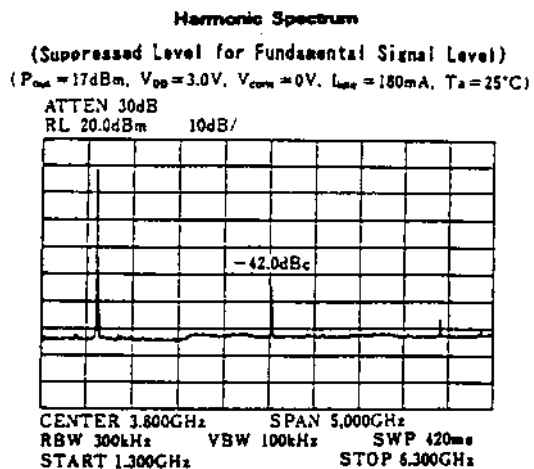
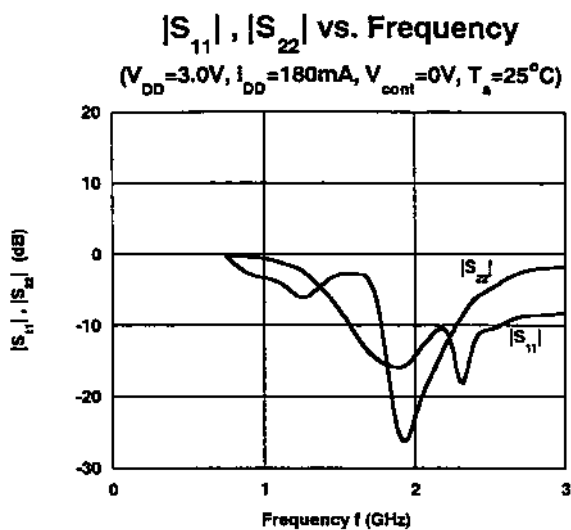

※All adjacent channel leakage power used in these evaluations are those of 600kHz offset from fundamental wave at PHS operating condition($\pi/4$ QPSK modulation)

NJG1304E

RECOMMENDED CIRCUIT

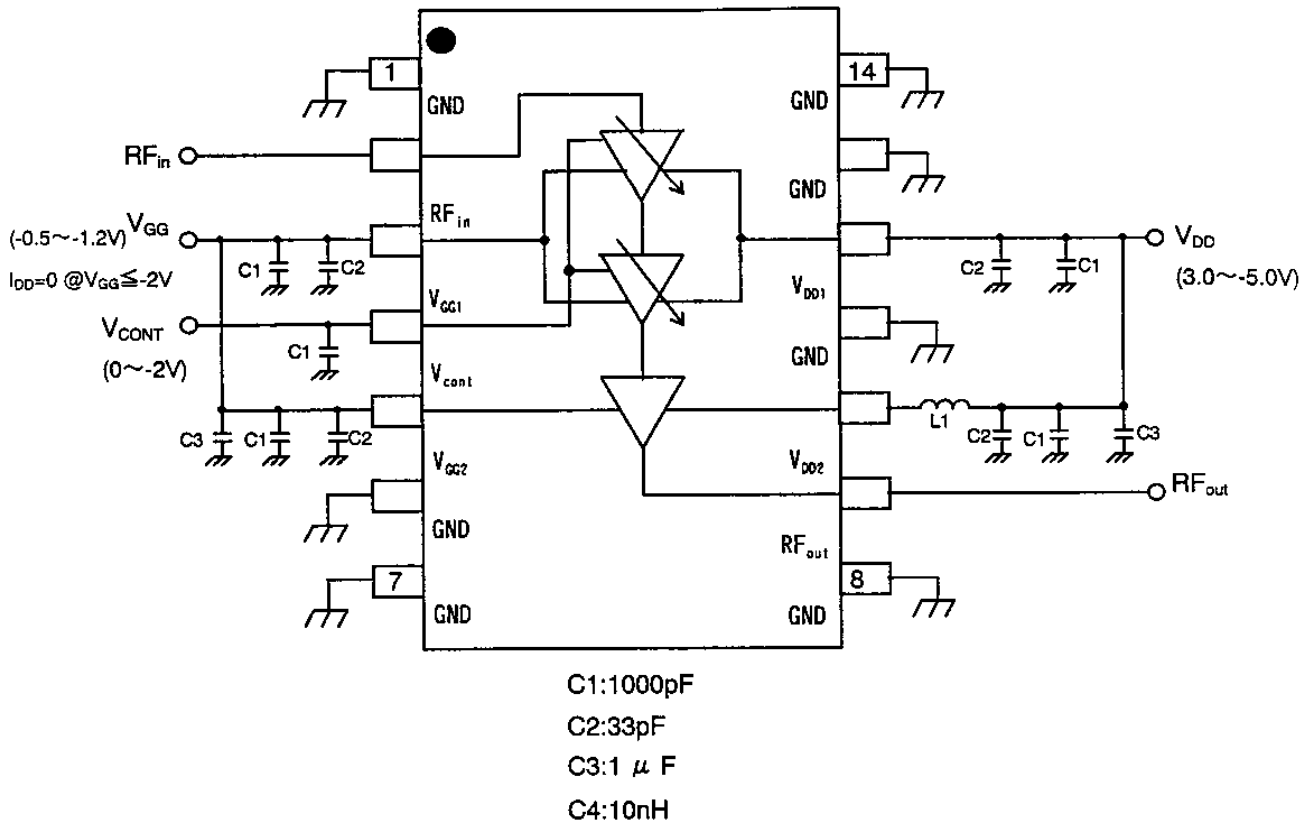

RECOMMENDED CIRCUIT TO GENERATE NEGATIVE VOLTAGE

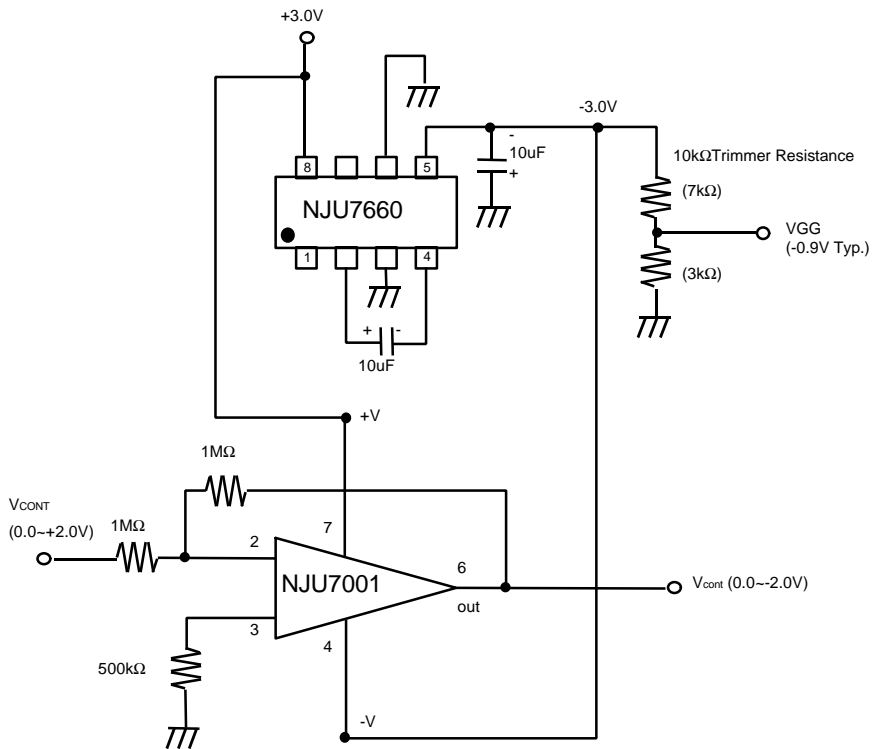

RECOMMENDED PCB DESIGN

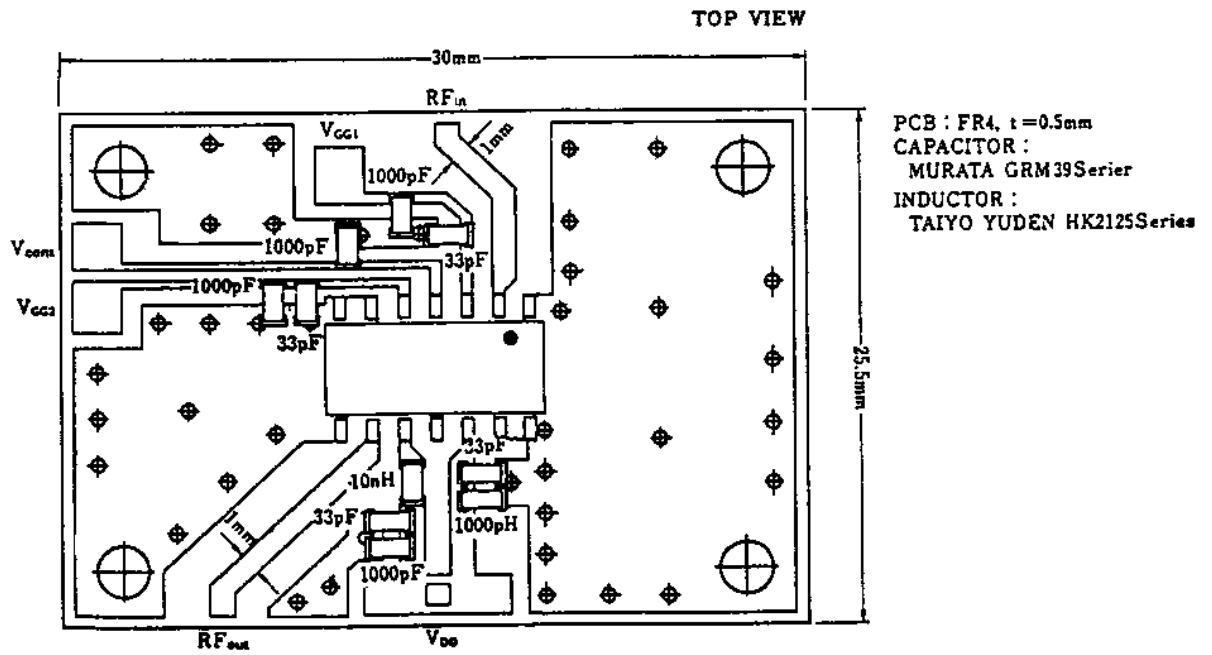

The reflow method is recommended for this device to attach on PCB

NJG1304E

PAKAGE OUTLINE(EMP14)

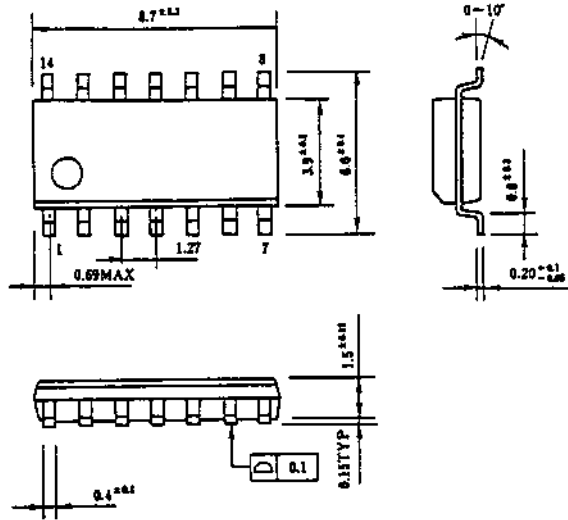

Lead material	: Copper
Lead surface finish	: Solder plating
Molding material	: Epoxy resin
UNIT	: mm
Weight	: 130mg

Cautions on using this product

This product contains Gallium-Arsenide (GaAs) which is a harmful material.

- Do NOT eat or put into mouth.
- Do NOT dispose in fire or break up this product.
- Do NOT chemically make gas or powder with this product.
- To waste this product, please obey the relating law of your country.

[CAUTION]

The specifications on this databook are only given for information, without any guarantee as regards either mistakes or omissions. The application circuits in this databook are described only to show representative usages of the product and not intended for the guarantee or permission of any right including the industrial rights.

This product may be damaged with electric static discharge (ESD) or spike voltage. Please handle with care to avoid these damages.