

DESCRIPTION

The 3807 group is a 8-bit microcomputer based on the 740 family core technology.

The 3807 group has two serial I/Os, an A-D converter, a D-A converter, a real time output port function, a watchdog timer, and an analog comparator, which are available for a system controller which controls motors of office equipment and household appliances.

The various microcomputers in the 3807 group include variations of internal memory size and packaging. For details, refer to the section on part numbering.

For details on availability of microcomputers in the 3807 group, refer to the section on group expansion.

FEATURES

- Basic machine-language instructions 71
- The minimum instruction execution time 0.5 μ s (at 8 MHz oscillation frequency)
- Memory size
 - ROM 8 to 60 K bytes
 - RAM 384 to 2048 bytes
- Programmable input/output ports 68
- Software pull-up resistors (Ports P0 to P2) 24
- Input ports (Ports P63 and P64) 2
- Interrupts 20 sources, 16 vectors
- Timers X, Y 16-bit X 2
- Timers A, B (for real time output port function) 16-bit X 2
- Timers 1-3 8-bit X 3

- Serial I/O1 (UART or Clock-synchronized) 8-bit X 1
- Serial I/O2 (Clock-synchronized) 8-bit X 1
- A-D converter 8-bit X 13 channels
- D-A converter 8-bit X 4 channels
- Watchdog timer 16-bit X 1
- Analog comparator 1 channel
- 2 Clock generating circuit
 - Main clock (XIN-XOUT) Internal feedback resistor
 - Sub-clock (XCIN-XCOUT) Without internal feedback resistor (connect to external ceramic resonator or quartz-crystal oscillator)
- Power source voltage
 - In high-speed mode 4.0 to 5.5 V (at 8 MHz oscillation frequency and high-speed selected)
 - In middle-speed mode 2.7 to 5.5 V (at 8 MHz oscillation frequency and middle-speed selected)
 - In low-speed mode 2.7 to 5.5 V (at 32 kHz oscillation frequency and low-speed selected)
- Power dissipation
 - In high-speed mode 34 m W (at 8 MHz oscillation frequency, at 5 V power source voltage)
 - In low-speed mode 60 μ W (at 32 kHz oscillation frequency, at 3 V power source voltage)
- Memory expansion possible
- Operating temperature range -20 to 85 $^{\circ}$ C

APPLICATION

LBP engine control, PPC, FAX, office equipment, household appliances, consumer electronics, etc.

PIN CONFIGURATION (TOP VIEW)

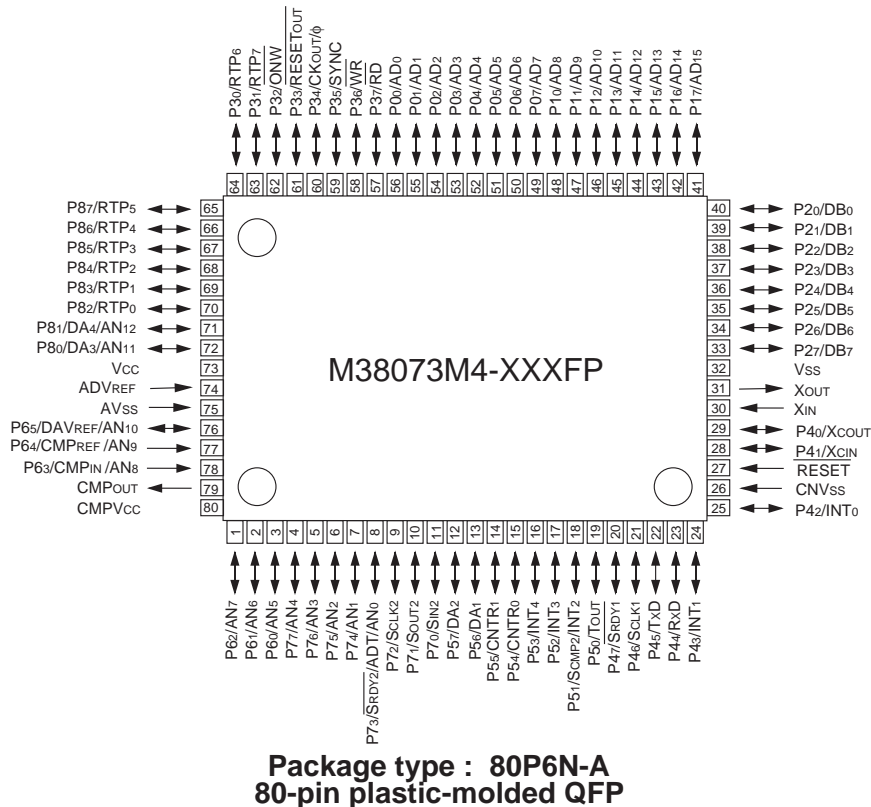

Fig. 1. Pin configuration of M38073M4-XXXXFP

FUNCTIONAL BLOCK

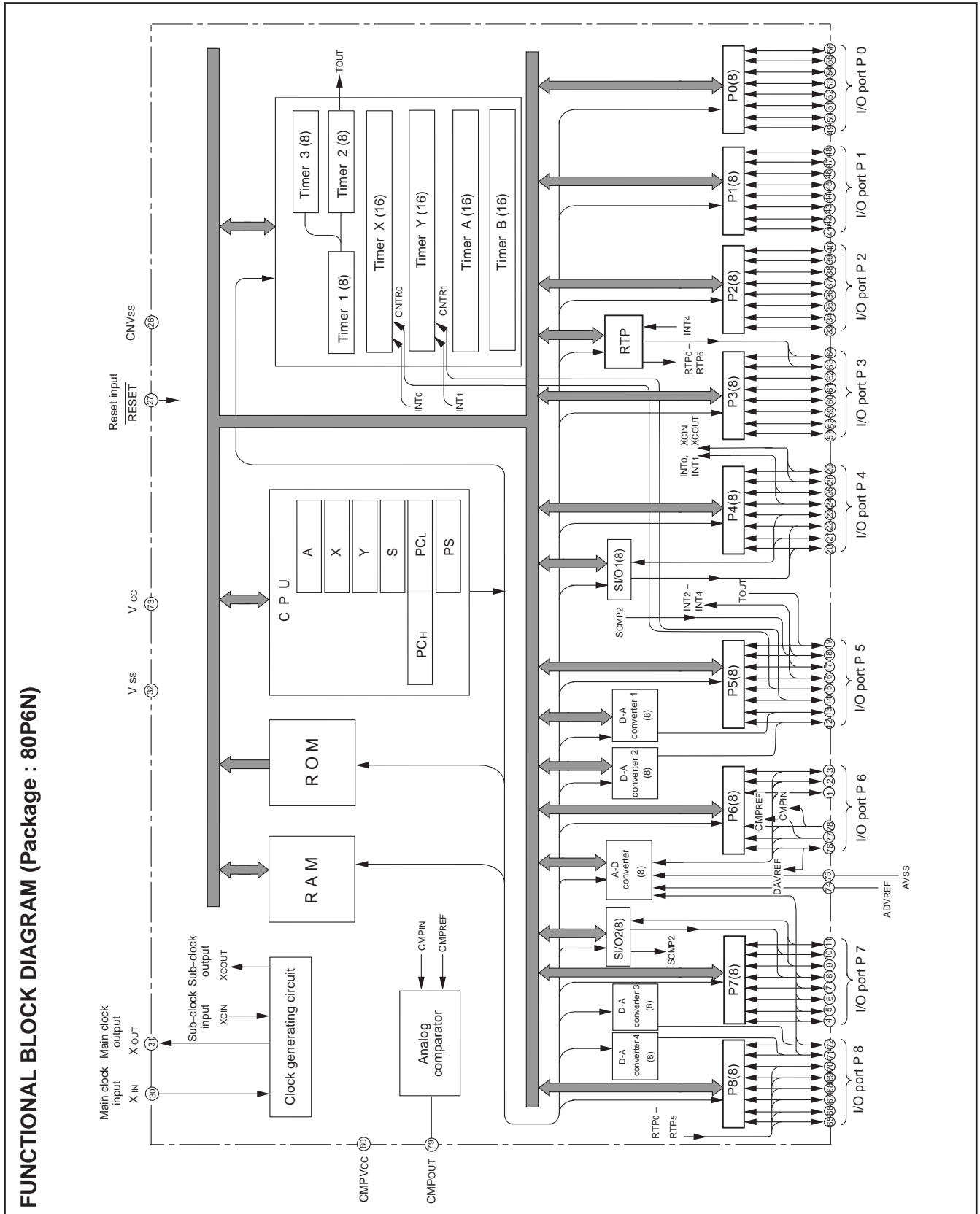

Fig. 2. Functional block diagram

PIN DESCRIPTION

Table 1. Pin description (1)

Pin	Name	Function	Function except a port function
Vcc, Vss	Power source	• Apply voltage of 2.7–5.5 V to Vcc, and 0 V to Vss.	
CMPVcc	Analog comparator power source	• Power source input pin for an analog comparator	
CNVss	CNVss	• This pin controls the operation mode of the chip. • Normally connected to Vss. • If this pin is connected to Vcc, the internal ROM is inhibited and external memory is accessed.	
ADVREF	Analog reference voltage	• Reference voltage input pin for A-D converter.	
AVss	Analog power source	• Analog power source input pin for A-D and D-A converter and an analog comparator • Connect to Vss.	
CMPOUT	Analog comparator output	• Output pin for an analog comparator	
RESET	Reset input	• Reset input pin for active "L"	
XIN	Clock input	• Input and output signals for the internal clock generating circuit. • Connect a ceramic resonator or quartz-crystal oscillator between the XIN and XOUT pins to set the oscillation frequency.	
XOUT	Clock output	• If an external clock is used, connect the clock source to the XIN pin and leave the XOUT pin open. • The clock is used as the oscillating source of system clock.	
P00–P07	I/O port P0	• 8-bit CMOS I/O port	
P10–P17	I/O port P1	• I/O direction register allows each pin to be individually programmed as either input or output.	
P20–P27	I/O port P2	• At reset this port is set to input mode. • In modes other than single-chip, these pins are used as address, data bus I/O pins. • CMOS compatible input level • CMOS 3-state output structure • Port P2 can be switched CMOS or TTL input level.	
P30/RTP6, P31/RTP7	I/O port P3	• 8-bit CMOS I/O port	• Real time port function pins
P34/CKOUT,		• I/O direction register allows each pin to be individually programmed as either input or output.	• Clock output function pin
P32, P33, P35–P37		• At reset this port is set to input mode. • In modes other than single-chip, these pins are used as control bus I/O pins. • CMOS compatible input level • CMOS 3-state output structure • Port P32 can be switched CMOS or TTL input level.	
P40/XCOUT, P41/XCIN	I/O port P4	• 8-bit CMOS I/O port with the same function as port P0	• Sub-clock generating I/O pins(connect a resonator)
P42/INT0, P43/INT1		• CMOS compatible input level • CMOS 3-state output structures	• Interrupt input pins • Timer X, Timer Y function pins (INT0, INT1)
P44/RxD, P45/TxD, P46/SCLK1, P47/SRDY1			• Serial I/O1 function pins
P50/TOU		• 8-bit CMOS I/O port with the same function as port P0	• Timer 2 output pin
P51/SCMP2/ INT2		• CMOS compatible input level • CMOS 3-state output structure	• Interrupt input pin • Serial I/O2 function pin
P52/INT3, P53/INT4		• Interrupt input pin	
P54/CNTR0, P55/CNTR1		• Real time port function pin(INT4) • Timer X, Timer Y function pins	
P56/DA1, P57/DA2		• D-A conversion output pins	

Table 2. Pin description (2)

Pin	Name	Function	Function except a port function
P60/AN5– P62/AN7	I/O port P6	<ul style="list-style-type: none"> • 3-bit CMOS I/O port with the same function as port P0 • CMOS compatible input level • CMOS 3-state output structure 	<ul style="list-style-type: none"> • A-D conversion output pins
P63/CMPIN/ AN8	Input port P6	<ul style="list-style-type: none"> • 2-bit CMOS input port • CMOS compatible input level 	<ul style="list-style-type: none"> • Analog comparator input pin • A-D conversion input pin
P64/CMPREF/ AN9			<ul style="list-style-type: none"> • Reference voltage input pin for analog comparator • A-D conversion input pin
P65/DAVREF/ AN10	I/O port P6	<ul style="list-style-type: none"> • 1-bit CMOS I/O port with the same function as port P0 • CMOS compatible input level • CMOS 3-state output structure 	<ul style="list-style-type: none"> • D-A conversion power source input pin • A-D conversion input pin
P70/SIN2, P71/SOUT2, P72/SCLK2	I/O port P7	<ul style="list-style-type: none"> • 8-bit CMOS I/O port with the same function as port P0 • CMOS compatible input level • CMOS 3-state output structures 	<ul style="list-style-type: none"> • Serial I/O2 function pins
P73/SRDY2/ ADT/AN0			<ul style="list-style-type: none"> • Serial I/O2 function pin • A-D conversion input pin • A-D trigger input pin
P74/AN1– P77/AN4			<ul style="list-style-type: none"> • A-D conversion input pin
P80/DA3/ AN11, P81/DA4/ AN12, P82/RTP0– P87/RTP5	I/O port P8	<ul style="list-style-type: none"> • 8-bit CMOS I/O port with the same function as port P0 • CMOS compatible input level • CMOS 3-state output structures 	<ul style="list-style-type: none"> • D-A conversion output pin • A-D conversion input pin
			<ul style="list-style-type: none"> • Realtime port function pins

PART NUMBERING

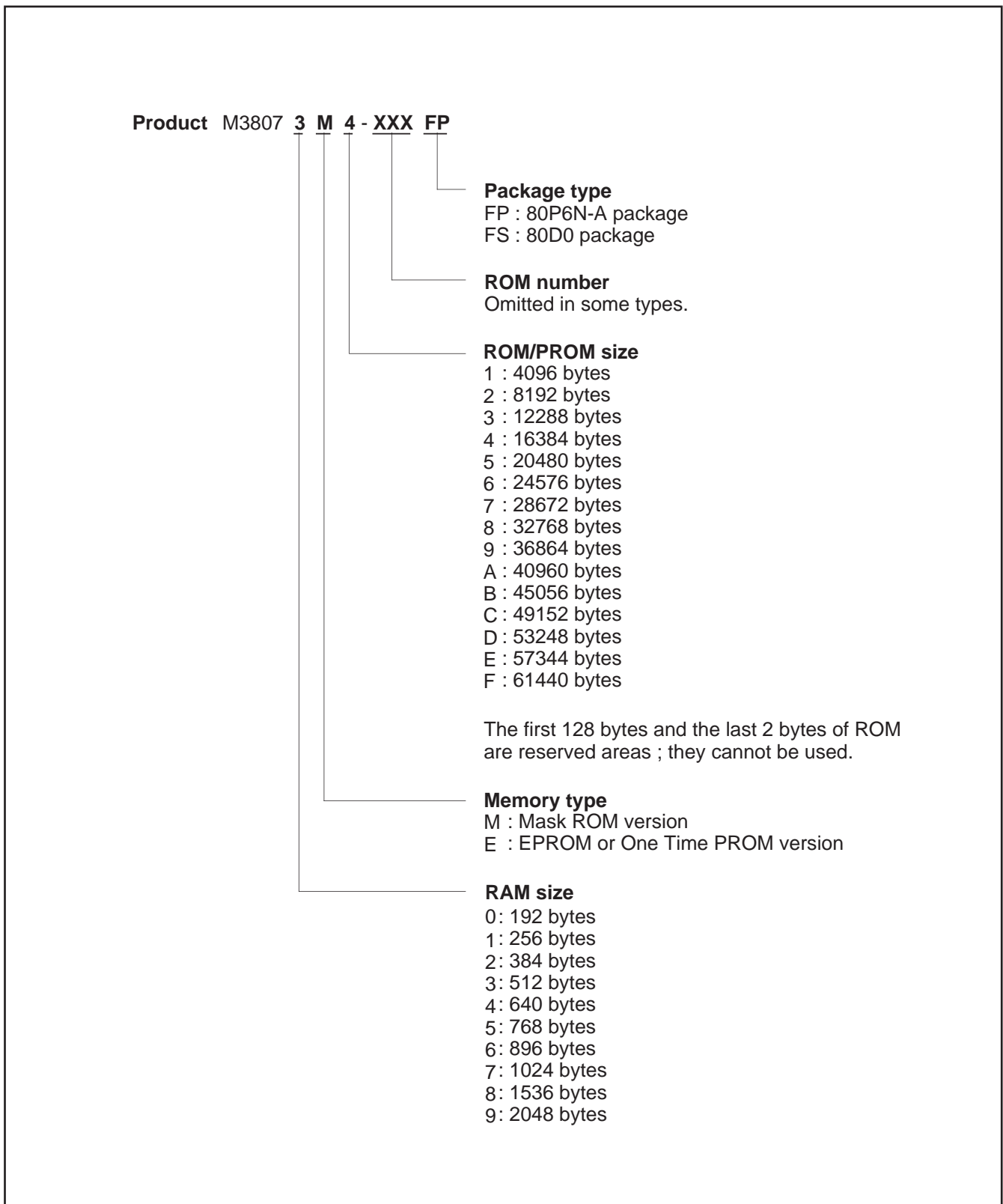

Fig. 3. Part numbering

GROUP EXPANSION

Mitsubishi plans to expand the 3807 group as follows:

Memory Type

Support for Mask ROM, One Time PROM and EPROM versions.

Memory Size

ROM/PROM size 8K to 60K bytes

RAM size 384 to 2048 bytes

Package

80P6N-A 0.8 mm-pitch plastic molded QFP

80D0 0.8 mm-pitch ceramic LCC (EPROM version)

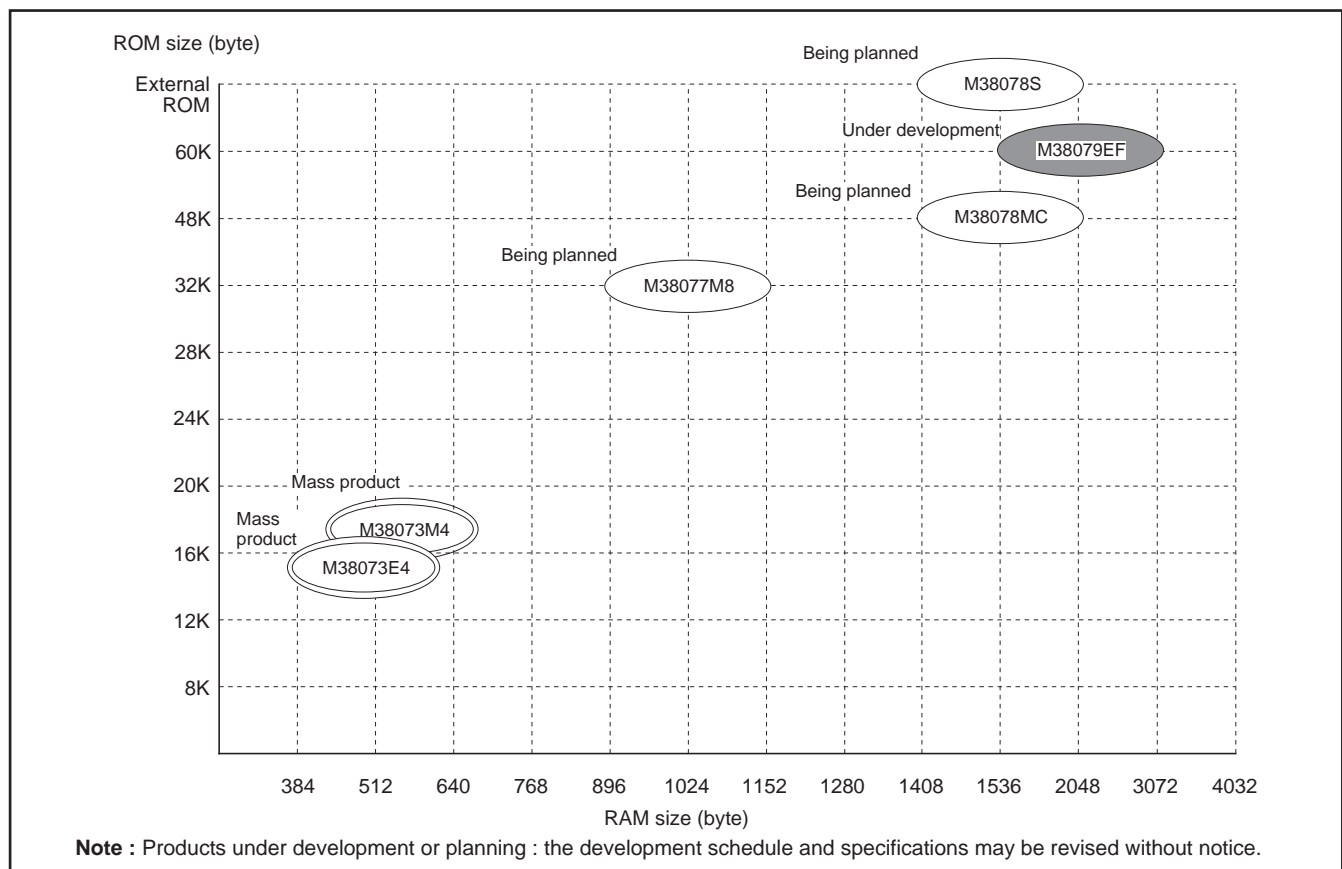

Fig. 4. Memory expansion plan

Currently supported products are listed below.

Table 3. List of supported products

As of May 1996

Product	(P) ROM size (bytes) ROM size for User ()	RAM size (bytes)	Package	Remarks
M38073M4-XXXFP	16384 (16254)	512	80P6N-A	Mask ROM version
M38073E4-XXXFP				One Time PROM version
M38073E4FP				One Time PROM version (blank)
M38073E4FS			80D0	EPROM version

FUNCTIONAL DESCRIPTION
Central Processing Unit (CPU)

The 3807 group uses the standard 740 family instruction set. Refer to the table of 740 family addressing modes and machine instructions or the SERIES 740 <Software> User's Manual for details on the instruction set.

Machine-resident 740 family instructions are as follows:

The FST and SLW instructions cannot be used.

The MUL, DIV, WIT and STP instruction can be used.

The central processing unit (CPU) has the six registers.

CPU Mode Register

The CPU mode register contains the stack page selection bit and processor mode bits. The CPU mode register is allocated at address 003B₁₆.

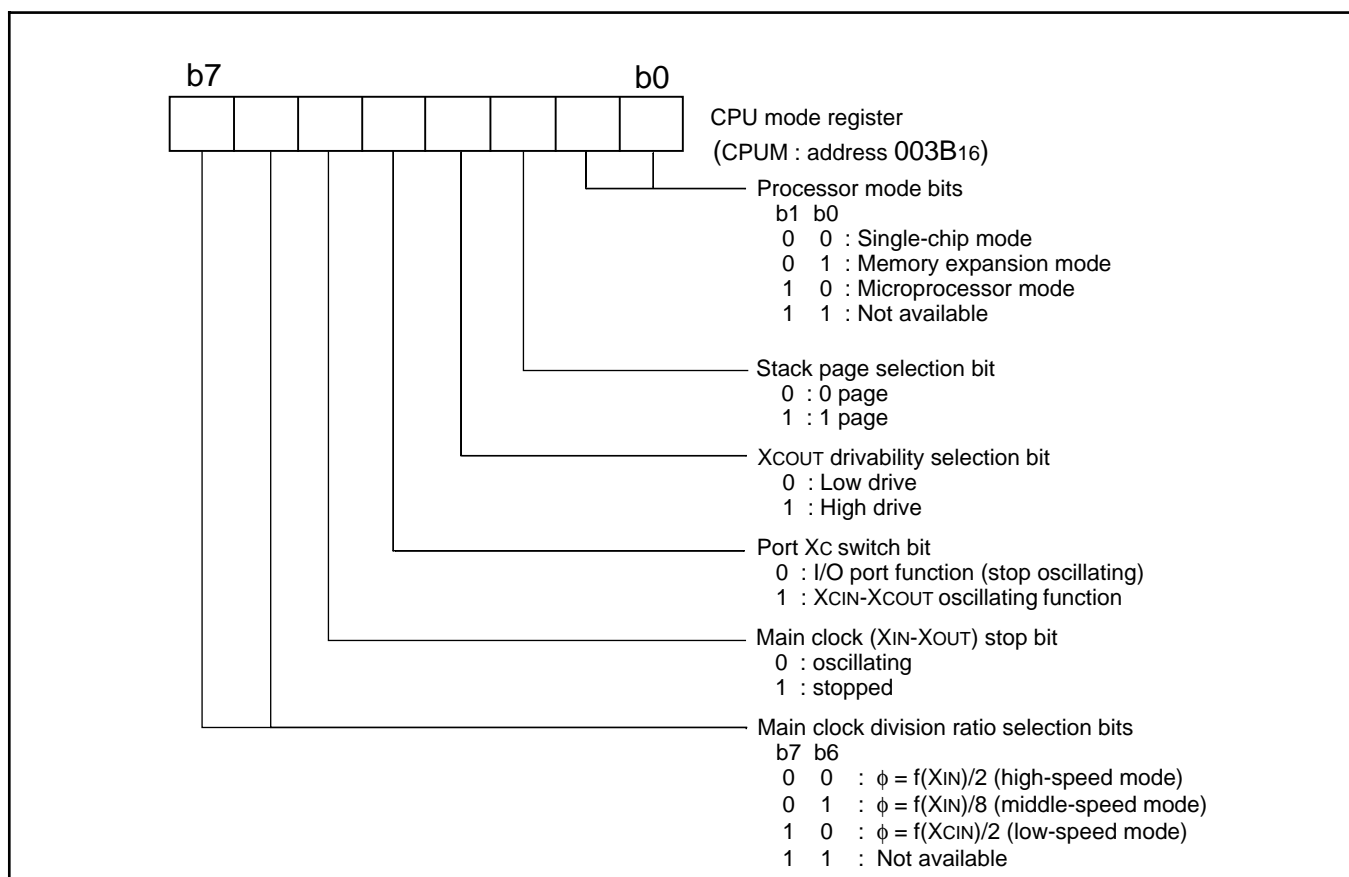

Fig. 5. Structure of CPU mode register

SINGLE-CHIP 8-BIT CMOS MICROCOMPUTER

Memory

Special function register (SFR) area

The special function register (SFR) area in the zero page contains control registers such as I/O ports and timers.

RAM

RAM is used for data storage and for stack area of subroutine calls and interrupts.

ROM

The first 128 bytes and the last 2 bytes of ROM are reserved for device testing and the reset is user area for storing programs.

Interrupt vector area

The interrupt vector area contains reset and interrupt vectors.

Zero page

The 256 bytes from addresses 0000₁₆ to 00FF₁₆ are called the zero page area. The internal RAM and the special function registers (SFR) are allocated to this area.

The zero page addressing mode can be used to specify memory and register addresses in the zero page area. Access to this area with only 2 bytes is possible in the zero page addressing mode.

Special page

The 256 bytes from addresses FF00₁₆ to FFFF₁₆ are called the special page area. The special page addressing mode can be used to specify memory addresses in the special page area. Access to this area with only 2 bytes is possible in the special page addressing mode.

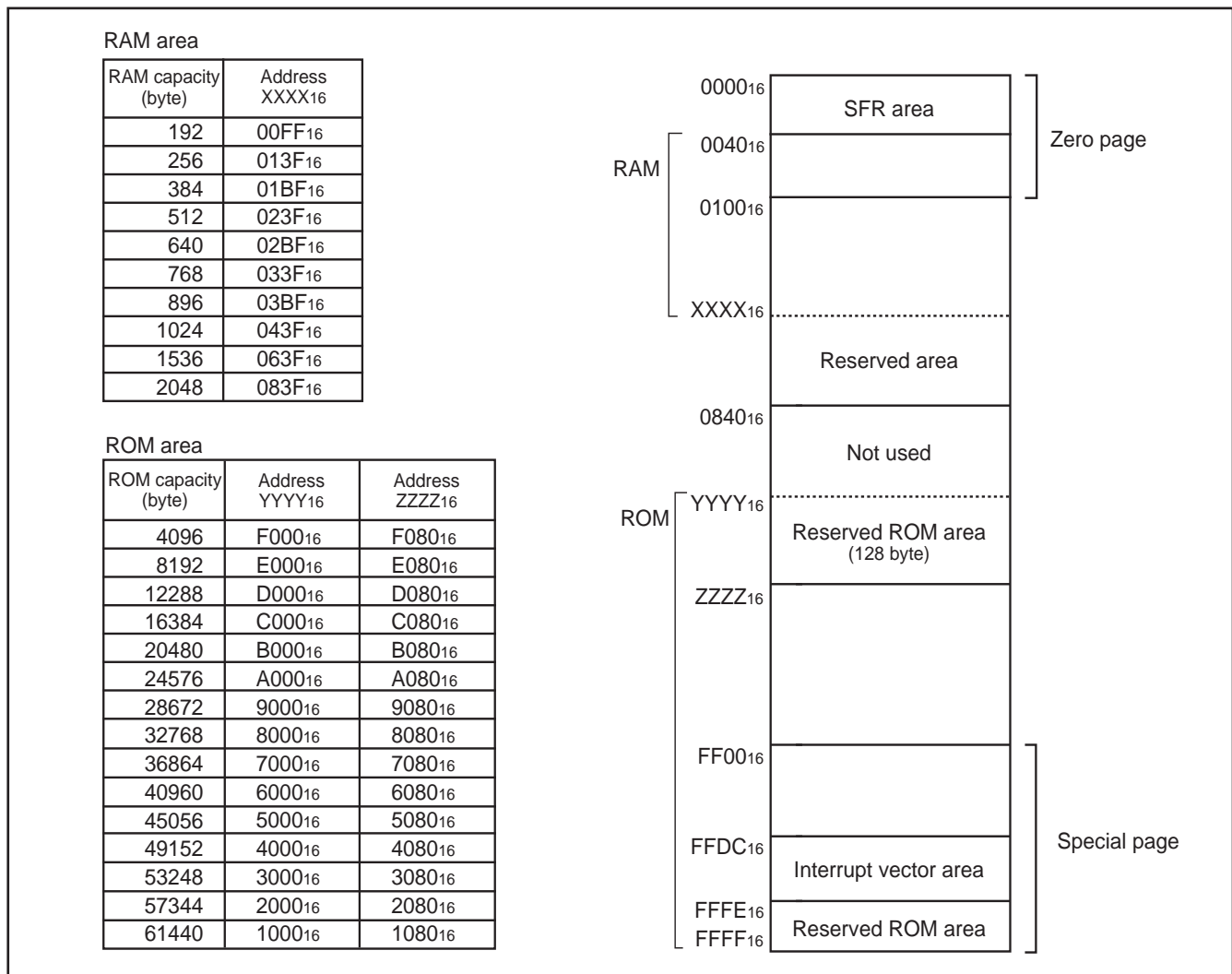

Fig. 6. Memory map diagram

0000 ₁₆	Port P0 (P0)	0020 ₁₆	Timer X (low-order) (TXL)
0001 ₁₆	Port P0 direction register (P0D)	0021 ₁₆	Timer X (high-order) (TXH)
0002 ₁₆	Port P1 (P1)	0022 ₁₆	Timer Y (low-order) (TYL)
0003 ₁₆	Port P1 direction register (P1D)	0023 ₁₆	Timer Y (high-order) (TYH)
0004 ₁₆	Port P2 (P2)	0024 ₁₆	Timer 1 (T1)
0005 ₁₆	Port P2 direction register (P2D)	0025 ₁₆	Timer 2 (T2)
0006 ₁₆	Port P3 (P3)	0026 ₁₆	Timer 3 (T3)
0007 ₁₆	Port P3 direction register (P3D)	0027 ₁₆	Timer X mode register (TXM)
0008 ₁₆	Port P4 (P4)	0028 ₁₆	Timer Y mode register (TYM)
0009 ₁₆	Port P4 direction register (P4D)	0029 ₁₆	Timer 123 mode register (T123M)
000A ₁₆	Port P5 (P5)	002A ₁₆	Real time port register (RTP)
000B ₁₆	Port P5 direction register (P5D)	002B ₁₆	Real time port control register 0 (RTPCON0)
000C ₁₆	Port P6 (P6)	002C ₁₆	Real time port control register 1 (RTPCON1)
000D ₁₆	Port P6 direction register (P6D)	002D ₁₆	Real time port control register 2 (RTPCON2)
000E ₁₆	Port P7 (P7)	002E ₁₆	Real time port control register 3 (RTPCON3)
000F ₁₆	Port P7 direction register (P7D)	002F ₁₆	Timer A (low-order) (TAL)
0010 ₁₆	Port P8 (P8)	0030 ₁₆	Timer A (high-order) (TAH)
0011 ₁₆	Port P8 direction register (P8D)	0031 ₁₆	Timer B (low-order) (TBL)
0012 ₁₆		0032 ₁₆	Timer B (high-order) (TBH)
0013 ₁₆		0033 ₁₆	D-A control register (DACON)
0014 ₁₆	Timer XY control register (TXYCON)	0034 ₁₆	A-D control register (ADCON)
0015 ₁₆	Port P2P3 control register (P2P3C)	0035 ₁₆	A-D conversion register (AD)
0016 ₁₆	Pull-up control register (PULL)	0036 ₁₆	D-A1 conversion register (DA1)
0017 ₁₆	Watchdog timer control register (WDTCON)	0037 ₁₆	D-A2 conversion register (DA2)
0018 ₁₆	Transmit/Receive buffer register (TB/RB)	0038 ₁₆	D-A3 conversion register (DA3)
0019 ₁₆	Serial I/O1 status register (SIO1STS)	0039 ₁₆	D-A4 conversion register (DA4)
001A ₁₆	Serial I/O1 control register (SIO1CON)	003A ₁₆	Interrupt edge selection register (INTEDGE)
001B ₁₆	UART control register (UARTCON)	003B ₁₆	CPU mode register (CPUM)
001C ₁₆	Baud rate generator (BRG)	003C ₁₆	Interrupt request register 1 (IREQ1)
001D ₁₆	Serial I/O2 control register 1 (SIO2CON1)	003D ₁₆	Interrupt request register 2 (IREQ2)
001E ₁₆	Serial I/O2 control register 2 (SIO2CON2)	003E ₁₆	Interrupt control register 1 (ICON1)
001F ₁₆	Serial I/O2 register (SIO2)	003F ₁₆	Interrupt control register 2 (ICON2)

Fig. 7. Memory map of special function register (SFR)

I/O Ports

[Direction Registers] PiD

The 3807 group has 68 programmable I/O pins arranged in nine individual I/O ports (P0—P5, P6₀—P6₂, P6₅ and P7—P8). The I/O ports have direction registers which determine the input/output direction of each individual pin. Each bit in a direction register corresponds to one pin, each pin can be set to be input port or output port. When "0" is written to the bit corresponding to a pin, that pin becomes an input pin. When "1" is written to that pin, that pin becomes an output pin. If data is read from a pin set to output, the value of the port output latch is read, not the value of the pin itself. Pins set to input (the bit corresponding to that pin must be set to "0") are floating or the value of that pin can be written to. If a pin set to input is written to, only the port output latch is written to and the pin remains floating.

[Pull-up Control Register] PULL

Ports P0, P1 and P2 have built-in programmable pull-up resistors. The pull-up resistors are valid only in the case that the each control bit is set to "1" and the corresponding port direction registers are set to input mode.

(1) CMOS/TTL input level selection

Either CMOS input level or TTL input level can be selected as an input level for ports P2₀ to P2₇ and P3₂. The input level is selected by P2-P3₂ input level selection bit (b7) of the port P2P3 control register (address 0015₁₆). When the bit is set to "0", CMOS input level is selected. When the bit is set to "1", the TTL input level is selected. After this bit is re-set, its initial value depends on the state of the CNVss pin. When the CNVss pin is connected to Vss, the initial value becomes "0". When the CNVss pin is connected to Vcc, the initial value becomes "1".

(2) Notes on STP instruction execution

Make sure that the input level at each pin is either 0V or to Vcc during execution of the STP instruction. When an input level is at an intermediate potential, a current will flow from Vcc to Vss through the input-stage gate.

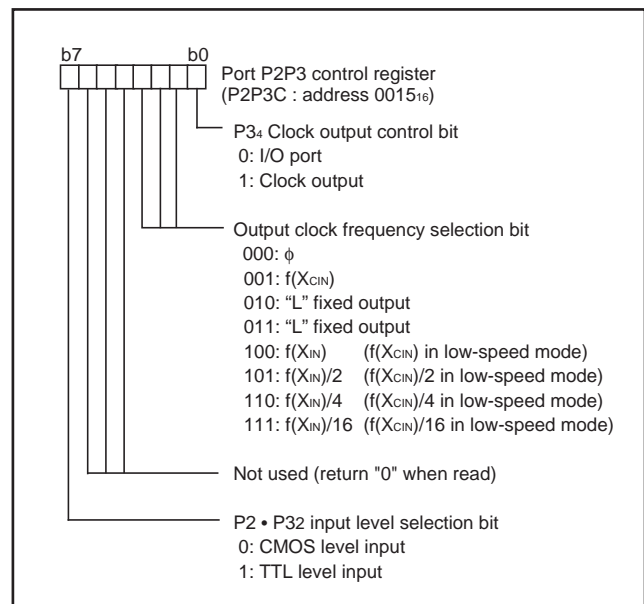

Fig. 8. Structure of Port P2P3 control register

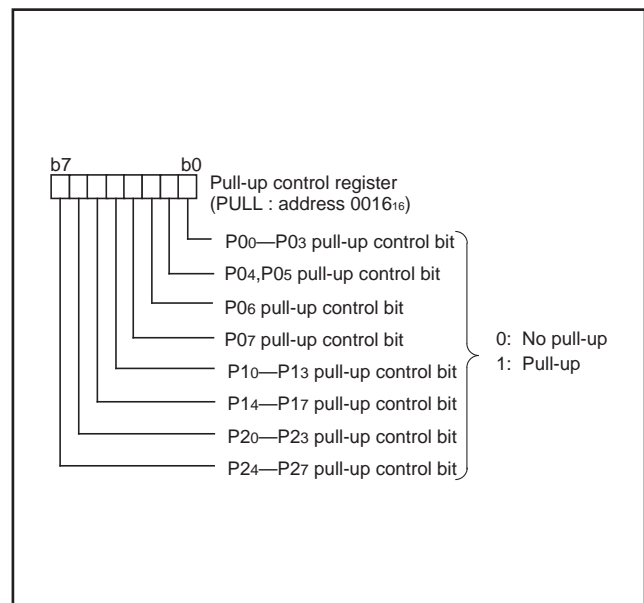

Fig. 9. Structure of Pull-up control register

SINGLE-CHIP 8-BIT CMOS MICROCOMPUTER

Table 4. List of I/O port functions (1)

Pin	Name	Input/Output	I/O Format	Non-Port Function	Related SFRs	Ref.No.	
P00–P07	Port P0	Input/output, individual bits	CMOS compatible input level	Address low-order byte output	CPU mode register	(1)	
P10–P17	Port P1		CMOS 3-state output	Address high-order byte output	Pull-up control register		
P20–P27	Port P2		CMOS/TTL input level CMOS 3-state output	Data bus I/O	CPU mode register Pull-up control register Port P2P3 control register		
P30/RTP6, P31/RTP7	Port P3		CMOS compatible input level	Real time port output	CPU mode register	(2)	
P32			CMOS 3-state output	Control signal input	Real time port control register		
P33			CMOS/TTL input level	Control signal output	CPU mode register	(3)	
			CMOS 3-state output	Control signal output	Port P2P3 control register		
P34/CKOUT	Port P4		CMOS compatible input level	Clock output, ϕ output	CPU mode register	(4)	
P35–P37			CMOS 3-state output	Control signal I/O	Port P2P3 control register		
			P40/XCOUT, P41/XCIN	Sub-clock generating circuit	CPU mode register	(5)	
P42/INT0, P43/INT1			External interrupt input	Interrupt edge selection register	(7)		
P44/RxD, P45/TxD, P46/SCLK1, P47/SRDY1			Timer X, Timer Y function input	Serial I/O1 control register UART control register	(8)		
			Serial I/O1 function I/O			(9)	
						(10)	
P50/TOUT			Port P5		Timer 2 output	Timer 123 mode register	(12)
P51/SCMP2/ INT2					External interrupt input	Interrupt edge selection register	(22)
					Serial I/O2 function I/O	Serial I/O2 control register	
P52/INT3, P53/INT4	External interrupt input	Interrupt edge selection register			(7)		
P54/CNTR0 P55/CNTR1	Real time port trigger input (INT4)	Timer X mode register Timer Y mode register			(13)		
	Timer X, Timer Y function I/O						
P56/DA1, P57/DA2	D-A conversion output	D-A control register			(14)		
P60/AN5— P62/AN7	A-D conversion input	A-D control register			(15)		
P63/CMPIN/ AN8	Input	CMOS compatible input level	Analog comparator input pin	A-D control register	(16)		
P64/CMPREF/ AN9			A-D conversion input				
P65/DAVREF/ AN10	Input/output, individual bits	CMOS compatible input level CMOS 3-state output	D-A converter power source	A-D control register	(17)		
			input				
P70/SIN2, P71/SOUT2, P72/SCLK2	Port P7		A-D conversion input	Serial I/O2 control register	(18)		
			Serial I/O2 function I/O			(19)	
						(20)	
P73/SRDY2/ ADT/AN0			Serial I/O2 function I/O	Serial I/O2 control register	(21)		
			A-D trigger input	A-D control register			
P74/AN1— P77/AN4			A-D conversion input	A-D control register	(15)		

SINGLE-CHIP 8-BIT CMOS MICROCOMPUTER

Table 5. List of I/O port functions (2)

Pin	Name	Input/Output	I/O Format	Non-Port Function	Related SFRs	Ref.No.
P8 ₀ /DA ₃ / AN ₁₁ P8 ₁ /DA ₄ / AN ₁₂	Port P8	Input/output, individual bits	CMOS compatible input level CMOS 3-state output	D-A conversion output A-D conversion input	D-A control register A-D control register	(14)
P8 ₂ /RTP ₀ — P8 ₇ /RTP ₅				Real time port output	Real time port control register	(23)

Note1 : For details of the functions of ports P0 to P3 in modes other than single-chip mode, and how to use double-function ports as function I/O ports, refer to the applicable sections.

2 : Make sure that the input level at each pin is either 0 V or V_{cc} during execution of the STP instruction.

When an input level is at an intermediate potential, a current will flow from V_{cc} to V_{ss} through the input-stage gate.

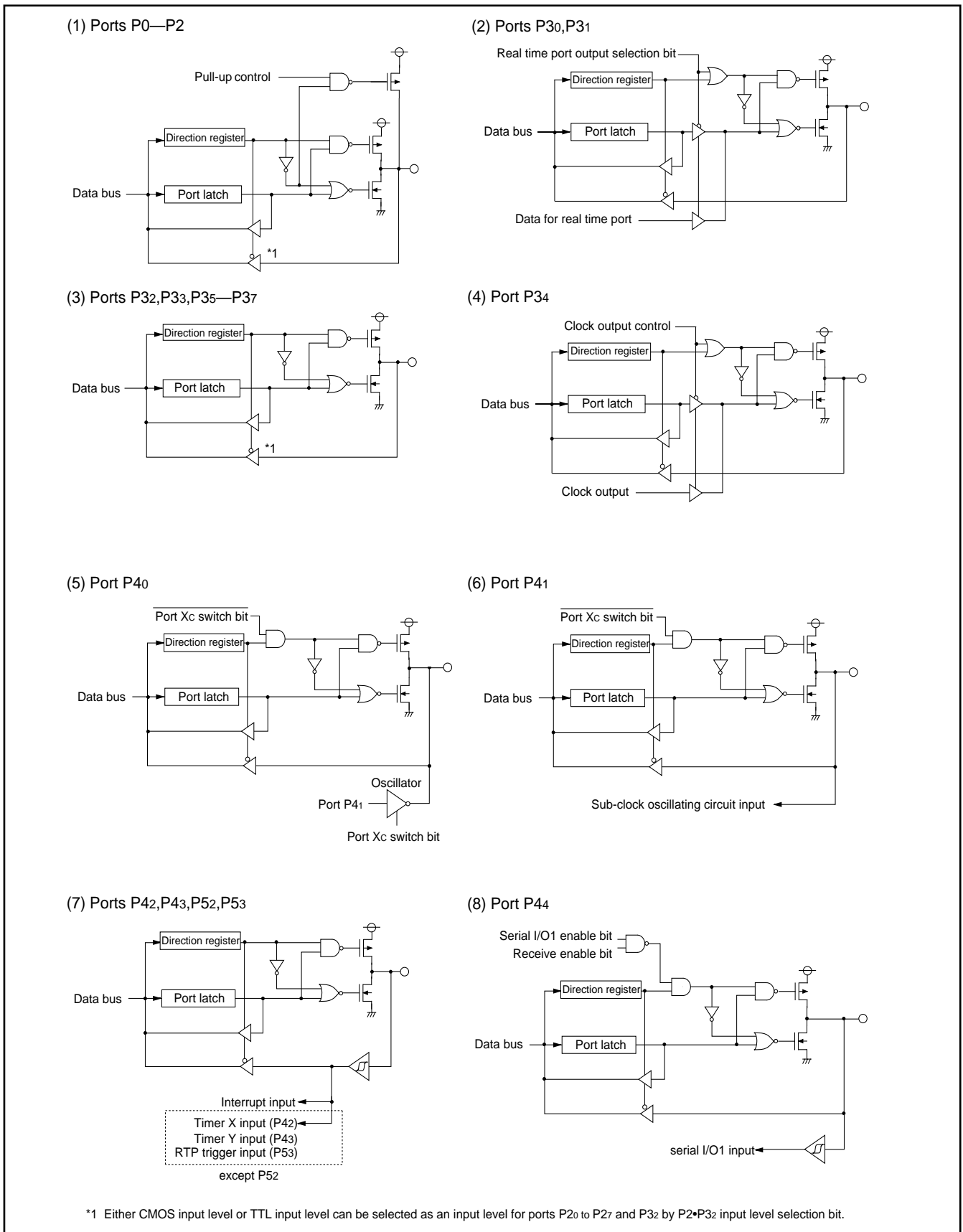

Fig. 10. Port block diagram (1)

SINGLE-CHIP 8-BIT CMOS MICROCOMPUTER

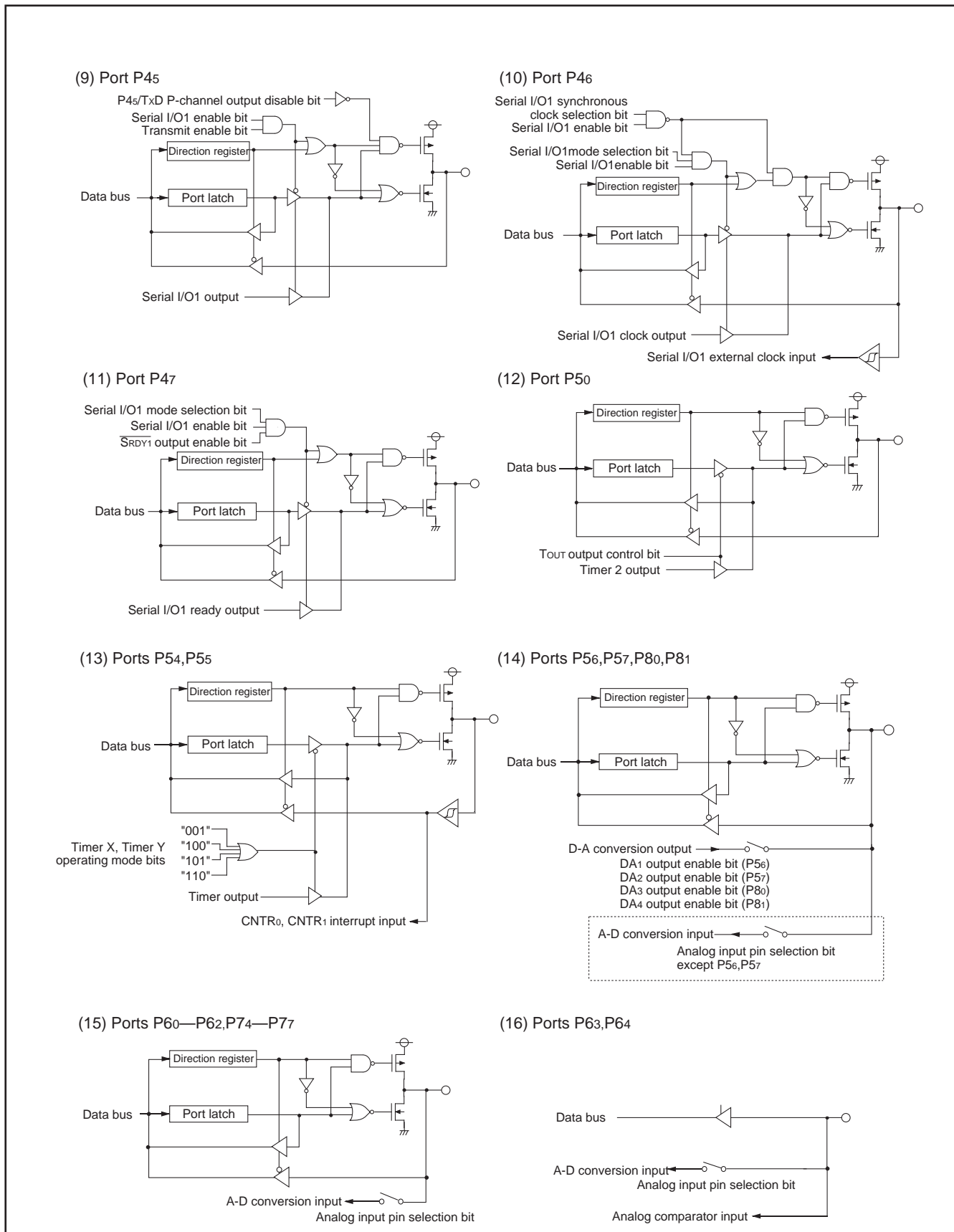

Fig. 11. Port block diagram (2)

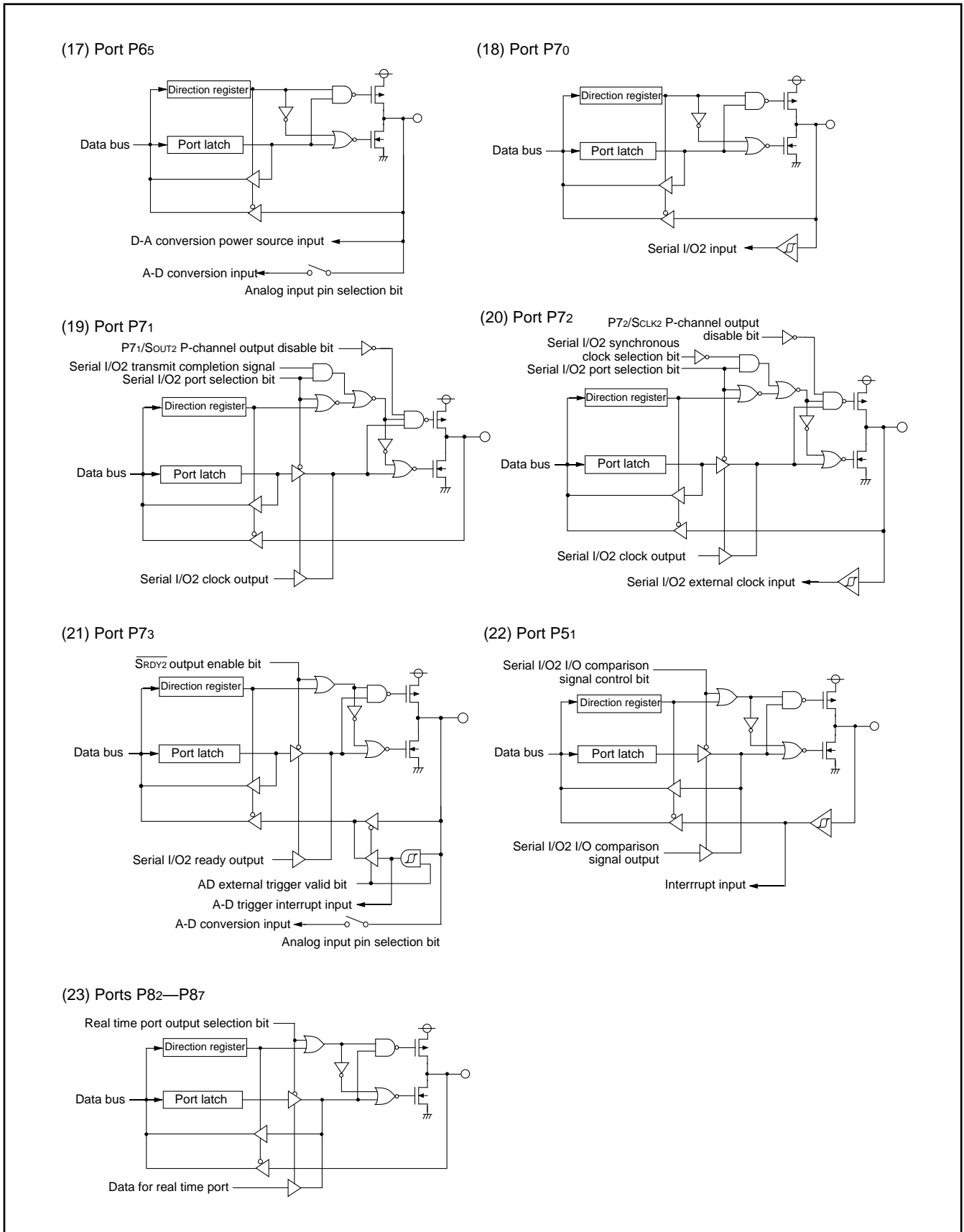

Fig. 12. Port block diagram (3)

Interrupts

Interrupts occur by twenty sources: eight external, eleven internal, and one software.

(1) Interrupt Control

Each interrupt except the BRK instruction interrupt have both an interrupt request bit and an interrupt enable bit, and is controlled by the interrupt disable flag. An interrupt occurs if the corresponding interrupt request and enable bits are "1" and the interrupt disable flag is "0". Interrupt enable bits can be set or cleared by software. Interrupt request bits can be cleared by software, but cannot be set by software. The BRK instruction interrupt and reset cannot be disabled with any flag or bit. The I flag disables all interrupts except the BRK instruction interrupt and reset. If several interrupts requests occurs at the same time the interrupt with highest priority is accepted first.

(2) Interrupt Operation

Upon acceptance of an interrupt the following operations are automatically performed:

1. The processing being executed is stopped.
2. The contents of the program counter and processor status register are automatically pushed onto the stack
3. Concurrently with the push operation, the interrupt jump destination address is read from the vector table into the program counter.
4. The interrupt disable flag is set and the corresponding interrupt request bit is cleared.

■Notes on Use

When the active edge of an external interrupt (INT₀—INT₄, CNTR₀ or CNTR₁) is set or the timer /INT interrupt source and the ADT/ A-D conversion interrupt source are changed, the corresponding interrupt request bit may also be set. Therefore, please take following sequence:

- (1) Disable the external interrupt which is selected.
- (2) Change the active edge in interrupt edge selection register (in case of CNTR₀: Timer X mode register ; in case of CNTR₁: Timer Y mode register).
- (3) Clear the set interrupt request bit to "0."
- (4) Enable the external interrupt which is selected.

SINGLE-CHIP 8-BIT CMOS MICROCOMPUTER

Table 6. Interrupt vector addresses and priority

Interrupt Source	Priority	Vector Addresses (Note 1)		Interrupt Request Generating Conditions	Remarks
		High	Low		
Reset (Note 2)	1	FFFD ₁₆	FFFC ₁₆	At reset	Non-maskable
INT ₀	2	FFFB ₁₆	FFFA ₁₆	At detection of either rising or falling edge of INT ₀ input	External interrupt (active edge selectable)
INT ₁	3	FFF9 ₁₆	FFF8 ₁₆	At detection of either rising or falling edge of INT ₁ input	External interrupt (active edge selectable)
Serial I/O1 receive	4	FFF7 ₁₆	FFF6 ₁₆	At completion of serial I/O1 data receive	Valid when serial I/O1 is selected
Serial I/O1 transmit	5	FFF5 ₁₆	FFF4 ₁₆	At completion of serial I/O1 data transmit shift or when transmit buffer is empty	Valid when serial I/O1 is selected
Timer X	6	FFF3 ₁₆	FFF2 ₁₆	At timer X underflow	
Timer Y	7	FFF1 ₁₆	FFF0 ₁₆	At timer Y underflow	
INT ₃	8	FFE _F 16	FFE _E 16	At detection of either rising or falling edge of INT ₃ input	External interrupt (active edge selectable) Valid when INT ₃ interrupt is selected
Timer 2				At timer 2 underflow	Valid when timer 2 interrupt is selected
INT ₄	9	FFE _D 16	FFE _C 16	At detection of either rising or falling edge of INT ₄ input	External interrupt (active edge selectable) Valid when INT ₄ interrupt is selected
Timer 3				At timer 3 underflow	Valid when timer 3 interrupt is selected
CNTR ₀	10	FFE _B 16	FFE _A 16	At detection of either rising or falling edge of CNTR ₀ input	External interrupt (active edge selectable)
CNTR ₁	11	FFE ₉ 16	FFE ₈ 16	At detection of either rising or falling edge of CNTR ₁ input	External interrupt (active edge selectable)
Serial I/O2	12	FFE ₇ 16	FFE ₆ 16	At completion of serial I/O2 data transmit and receive	Valid when serial I/O2 is selected
INT ₂	13	FFE ₅ 16	FFE ₄ 16	At detection of either rising or falling edge of INT ₂ input	External interrupt (active edge selectable) Valid when INT ₂ interrupt is selected
Timer 1				At timer 1 underflow	Valid when timer 1 interrupt is selected
Timer A	14	FFE ₃ 16	FFE ₂ 16	At timer A underflow	
Timer B	15	FFE ₁ 16	FFE ₀ 16	At timer B underflow	
A-D conversion ADT	16	FFD _F 16	FFD _E 16	At completion of A-D conversion	Valid when A-D interrupt is selected
				At falling edge of ADT input	External interrupt(valid at falling) Valid when ADT interrupt is selected and when A-D external trigger is selected.
BRK instruction	17	FFD _D 16	FFD _C 16	At BRK instruction execution	Non-maskable software interrupt

Note1 : Vector addresses contain interrupt jump destination addresses.

2 : Reset function in the same way as an interrupt with the highest priority.

SINGLE-CHIP 8-BIT CMOS MICROCOMPUTER

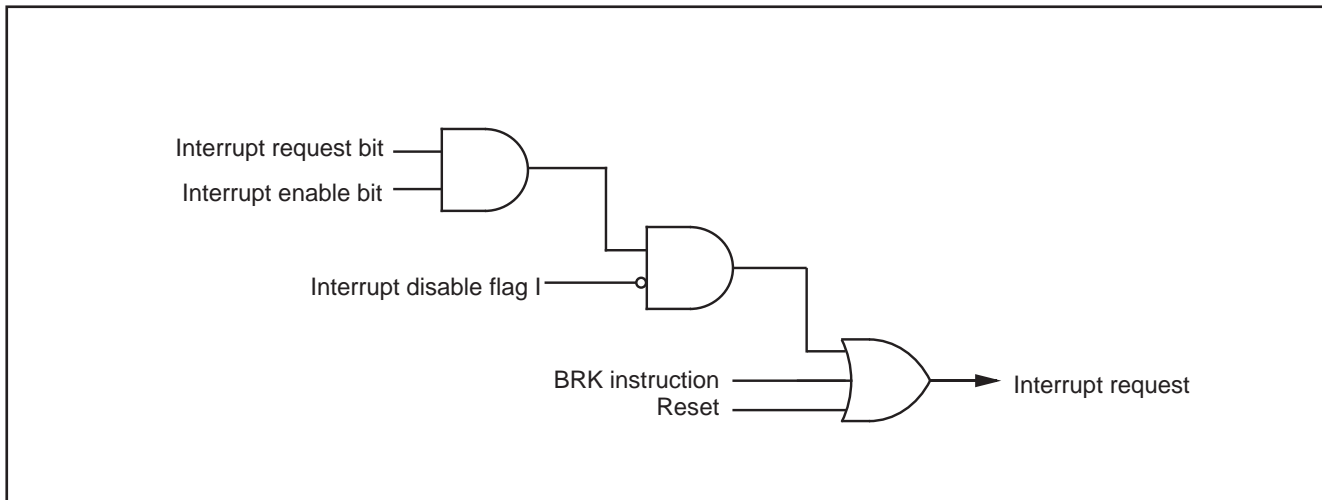

Fig. 13. Interrupt control

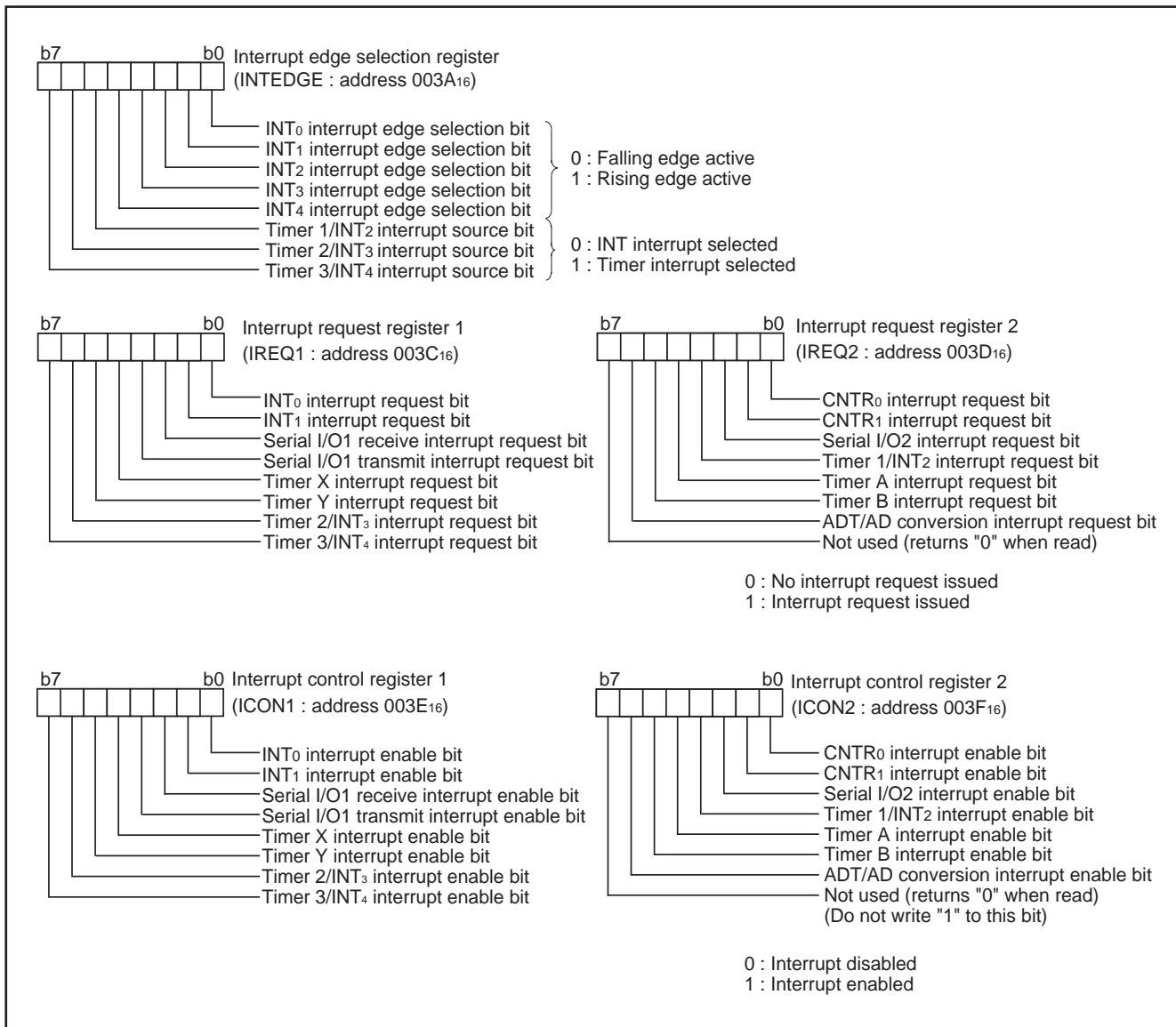

Fig. 14. Structure of Interrupt-related registers

Timers

The 3807 group has seven timers : four 16-bit timers (Timer X, Timer Y, Timer A, and Timer B) and three 8-bit timers (Timer 1, Timer 2, and Timer 3).

All timers are down-counters. When the timer reaches either "00₁₆" or "0000₁₆", an underflow occurs with the next count pulse. Then the contents of the timer latch is reloaded into the timer and the timer continues down-counting. When a timer underflows, the interrupt request bit corresponding to that timer is set to "1."

Read and write operation on 16-bit timer must be performed for both high- and low-order bytes. When reading a 16-bit timer, read from the high-order byte first. When writing to 16-bit timer, write to the low-order byte first. The 16-bit timer cannot perform the correct operation when reading during write operation, or when writing during read operation.

Timers A and B are real time output port timers. For details, refer to the section "Real time output port".

●Timer X, Timer Y

Timer X and Y are independent 16-bit timers which can select enable seven different operation modes each by the setting of their mode registers. The related registers of timer X and Y are listed below. The following register abbreviations are used:

- Timer XY control register (TXYCON: address 0014₁₆)
- Port P4 direction register (P4D: address 0009₁₆)
- Port P5 direction register (P5D: address 000B₁₆)
- Timer X (low-order) (TXL: address 0020₁₆)
- Timer X (high-order) (TXH: address 0021₁₆)
- Timer Y (low-order) (TYL: address 0022₁₆)
- Timer Y (high-order) (TYH: address 0023₁₆)
- Timer X mode register (TXM: address 0027₁₆)
- Timer Y mode register (TYM: address 0028₁₆)
- Interrupt edge selection register (INTEDGE: address 003A₁₆)
- Interrupt request register 1 (IREQ1: address 003C₁₆)
- Interrupt request register 2 (IREQ2: address 003D₁₆)
- Interrupt control register 1 (ICON1: address 003E₁₆)
- Interrupt control register 2 (ICON2: address 003F₁₆)

For details, refer to the structures of each register.

The following is an explanation of the seven modes:

(1) Timer • event counter mode

①Timer mode

- Mode selection

This mode can be selected by setting "000" to the following bits.

Timer X operating mode bit (bits 2 to 0) of TXM

Timer Y operating mode bit (bits 2 to 0) of TYM

- Count source selection

In high- or middle-speed mode, $f(X_{IN})/2$, $f(X_{IN})/16$, or $f(X_{CIN})$ can be selected as the count source.

In low-speed mode the count source is $f(X_{CIN})$.

A count source is selected by the following bit.

Timer X count source selection bit (bits 7 and 6) of TXM

Timer Y count source selection bit (bits 7 and 6) of TYM

- Interrupt

When an underflow is generated, the corresponding timer X interrupt request bit (b4) or timer Y interrupt request bit (b5) of IREQ1 is set to "1".

- Explanation of operation

After reset release, timer X stop control bit (b0) and timer Y stop control bit (b1) of TXYCON are set to "1" and the timer stops. During timer stop, a timer value written to the timer X or timer Y is set by writing data to the corresponding timer latch and timer at the same time. The timer operation is started by setting the bits 0 or 1 of TXYCON to "0". When the timer reaches "0000₁₆", an underflow occurs with the next count pulse. Then the contents of the timer latch is reloaded into the timer and the timer continues down-counting. For changing a timer value during count operation, a latch value must be changed by writing data only to the corresponding latch first. Then the timer is reloaded with the new latch value at the next underflow.

②Event counter mode

- Mode selection

This mode can be selected by the following sequence.

1. Set "000" to the timer X operating mode bit (bits 2 to 0) of TXM, or to the timer Y operating mode bit (bits 2 to 0) of TYM.
2. Select an input signal from the CNTR₀ pin (in case of timer X ; set "11" to bits 7 and 6 of TXM), or from the CNTR₁ pin (in case of timer Y ; set "11" to bits 7 and 6 of TYM) as a count source.

The valid edge for the count operation is selected by the CNTR₀/CNTR₁ active edge switch bit (b5) of TXM or TYM: if set to "0", counting starts with the rising edge or if set to "1", counting starts with the falling edge.

- Interrupt

The interrupt generation at underflow is the same as already explained for the timer mode.

- Explanation of operation

The operation is the same as already explained for the timer mode. In this mode, the double-function port of CNTR₀/CNTR₁ pin must be set to input.

Figure 19 shows the timing chart for the timer • event counter mode.

(2) Pulse output mode

- Mode selection

This mode can be selected by setting "001" to the following bits.

Timer X operating mode bit (bits 2 to 0) of TXM

Timer Y operating mode bit (bits 2 to 0) of TYM

- Count source selection

In high- or middle-speed mode, $f(X_{IN})/2$, $f(X_{IN})/16$, or $f(X_{CIN})$ can be selected as the count source.

In low-speed mode the count source is $f(X_{CIN})$.

- Interrupt

The interrupt generation at underflow is the same as already explained for the timer mode.

- Explanation of operation

Counting operation is the same as in timer mode. Moreover the pulse which is inverted each time the timer underflows is output from CNTR₀/CNTR₁ pin. When the CNTR₀/CNTR₁ active edge switch bit (b5) of TXM or TYM is "0", output starts with "H" level. When set to "1", output starts with "L" level.

■Precautions

Set the double-function port of CNTR0/CNTR1 pin to output in this mode.

[During timer operation stop]

The output from CNTR0/CNTR1 pin is initialized to the level set through CNTR0/CNTR1 active edge switch bit.

[During timer operation enabled]

When the value of the CNTR0/CNTR1 active edge switch bit is written over, the output level of CNTR0/CNTR1 pin is inverted.

Figure 20 shows the timing chart of the pulse output mode.

(3) Pulse period measurement mode

• Mode selection

This mode can be selected by setting "010" to the following bits.

Timer X operating mode bit (bits 2 to 0) of TXM

Timer Y operating mode bit (bits 2 to 0) of TYM

• Count source selection

In high- or middle-speed mode, $f(X_{IN})/2$ or $f(X_{IN})/16$ can be selected as the count source.

In low-speed mode the count source is $f(X_{CIN})$.

• Interrupt

The interrupt generation at underflow is the same as already explained for the timer mode. Bits 0 or 1 of IREQ2 is set to "1" synchronously to pulse period measurement completion.

• Explanation of operation

[During timer operation stop]

Select the count source. Next, select the interval of the pulse periods to be measured. When bit 5 of the TXM or TYM is set to "0", the timer counts during the interval of one falling edge of CNTR0/CNTR1 pin input until the next falling edge of input. If bit 5 is set to "1", the timer counts during the interval of one rising edge until the next rising edge.

[During timer operation enabled]

The pulse period measurement starts by setting bit 0 or 1 of TXYCON to "0" and the timer counts down from the value that was set to the timer before the start of measurement. When a valid edge of measurement start/stop is detected, the 1's complement of the timer value is written to the timer latch and "FFFF₁₆" is set to the timer. Furthermore when the timer underflows, a timer X/Y interrupt request occurs and "FFFF₁₆" is set to the timer. The measured value is held until the next measurement completion.

■Precautions

Set the double-function port of CNTR0/CNTR1 pin to input in this mode.

A read-out of timer value is impossible in this mode. The timer is written to only during timer stop (no measurement of pulse periods). Since the timer latch in this mode is specialized for the read-out of measured values, do not perform any write operations during measurement.

The timer is set to "FFFF₁₆" when the timer either underflows or a valid edge of pulse period measurement is detected. Due to that, the timer value at the start of measurement depends on the timer value before the start of measurement.

Figure 19 shows the timing chart of the pulse period measurement mode.

(4) Pulse width measurement mode

• Mode selection

This mode can be selected by setting "011" to the following bits.

Timer X operating mode bit (bits 2 to 0) of TXM

Timer Y operating mode bit (bits 2 to 0) of TYM

• Count source selection

In high- or middle-speed mode, $f(X_{IN})/2$ or $f(X_{IN})/16$ can be selected as the count source.

In low-speed mode the count source is $f(X_{CIN})$.

• Interrupt

The interrupt generation at underflow is the same as already explained for the timer mode. Bit 0 or 1 of IREQ2 is set to "1" synchronously to pulse width measurement completion.

• Explanation of operation

[During timer operation stop]

Select the count source. Next, select the interval of the pulse widths to be measured. When bit 5 of TXM or TYM is set to "1", the timer counts during the interval of one falling edge of CNTR0/CNTR1 pin input until the next rising edge of input ("L" interval). If bit 5 is set to "0", the timer counts during the interval of one rising edge until the next falling edge ("H" interval).

[During timer operation enabled]

The pulse width measurement starts by setting bit 0 or 1 of TXYCON to "0" and the timer counts down from the value that was set to the timer before the start of measurement. When a valid edge of measurement completion is detected, the 1's complement of the timer value is written to the timer latch and "FFFF₁₆" is set to the timer. Furthermore when the timer underflows, a timer X/Y interrupt request occurs and "FFFF₁₆" is set to the timer. The measured value is held until the next measurement completion.

■Precautions

Set the double-function port of CNTR0/CNTR1 pin to input in this mode.

A read-out of timer value is impossible in this mode. The timer is written to only during timer stop (no measurement of pulse widths). Since the timer latch in this mode is specialized for the read-out of measured values, do not perform any write operations during measurement.

The timer value is set to "FFFF₁₆" when the timer either underflows or a valid edge of pulse widths measurement is detected. Due to that, the timer value at the start of measurement depends on the timer value before the start of measurement.

Figure 20 shows the timing chart of the pulse width measurement mode.

(5) Programmable waveform generation mode

• Mode selection

This mode can be selected by setting "100" to the following bits.

Timer X operating mode bit (bits 2 to 0) of TXM

Timer Y operating mode bit (bits 2 to 0) of TYM

• Count source selection

In high- or middle-speed mode, $f(X_{IN})/2$, $f(X_{IN})/16$, or $f(X_{CIN})$ can be selected as the count source.

In low-speed mode the count source is $f(X_{CIN})$.

• Interrupt

The interrupt generation at underflow is the same as already

explained for the timer mode.

- Explanation of operation

Counting operation is the same as in timer mode. Moreover the timer outputs the data set in the corresponding output level latch (bit 4 of TXM or TYM) to CNTR₀/CNTR₁ pin each time the timer underflows. After the timer underflows, the generation of optional waveform from CNTR₀/CNTR₁ pin is possible through a change of values in the output level latch and timer latch.

- Precautions

Set the double-function port of CNTR₀/CNTR₁ pin to output in this mode.

Figure 23 shows the timing chart of the programmable waveform generation mode.

(6) Programmable one-shot generating mode

- Mode selection

This mode can be selected by setting "101" to the following bits.

Timer X operating mode bit (bits 2 to 0) of TXM

Timer Y operating mode bit (bits 2 to 0) of TYM

- Count source selection

In high- or middle-speed mode, $f(X_{IN})/2$ or $f(X_{IN})/16$ can be selected as the count source.

- Interrupt

The interrupt generation at underflow is the same as already explained for the timer mode. The one-shot generating trigger condition must be set to the INT₀ interrupt edge selection bit (b0) and INT₁ interrupt edge selection bit (b1) of INTEDGE. Setting these bits to "0" causes the interrupt request being triggered by a falling edge, setting them to "1" causes the interrupt request being triggered by a rising edge. The INT₀ interrupt request bit (b0) and INT₁ interrupt request bit (b1) of IREQ1 are set to "1" by detecting the active edge of the INT pin.

- Explanation of operation

For a "H" one-shot pulse, set bit 5 of TXM, TYM to "0".

[During timer operation stop]

The output level of CNTR₀/CNTR₁ pin is initialized to "L" at mode selection. Set the one-shot pulse width to TXH, TXL, TYH, TYL. A trigger generation during timer stop (input signal to INT₀/INT₁ pin) is invalid.

[During timer operation enabled]

When a trigger generation is detected, "H" is output, and at underflow "L" is output from CNTR₀/CNTR₁ pin.

For a "L" one-shot pulse set bit 5 of TXM, TYM to "1".

[During timer operation stop]

The output level of CNTR₀/CNTR₁ pin is initialized to "H" at mode selection. Set the one-shot pulse width to TXH, TXL, TYH, TYL. A trigger generation during timer stop (input signal to INT₀/INT₁ pin) is invalid.

[During timer operation enabled]

When a trigger generation is detected, "L" is output, and at underflow "H" is output from CNTR₀/CNTR₁ pin.

- Precautions

- Set the double-function port of CNTR₀/CNTR₁ pin to output and the double-function port of INT₀/INT₁ pin to input in this mode.
- This mode is unused in low-speed mode.

- During one-shot generation permission or one-shot generation the output level from CNTR₀/CNTR₁ pin changes if the value of the CNTR₀/CNTR₁ active edge switch bit is inverted.

Figure 24 shows the timing chart of the programmable one-shot generating mode.

(7) PWM mode

- Mode selection

This mode can be selected by setting "110" to the following bits.

Timer X operating mode bit (bits 2 to 0) of TXM

Timer Y operating mode bit (bits 2 to 0) of TYM

- Count source selection

In high- or middle-speed mode, $f(X_{IN})/2$ or $f(X_{IN})/16$ can be selected as the count source.

- Interrupt

With a rising edge of CNTR₀/CNTR₁ output, the timer X interrupt request bit (b4) and timer Y interrupt request bit (b5) of IREQ1 are set to "1".

- Explanation of operation

PWM waveform is output from CNTR₀ pin (in case of timer X) or from CNTR₁ pin (in case of timer Y).

The "H" interval of PWM waveform is determined by the setting value m ($m=0$ to 255) of TXH and TYH and the "L" interval of PWM waveform is determined by the setting value n ($n=0$ to 255) of TXL and TYL.

The PWM cycles are:

$$\text{PWM cycle time} = (m+n) \cdot t_s$$

$$\text{PWM duty} = m/(m+n)$$

where: t_s : period of timer X/timer Y count source

[During count operation stop]

When a timer value is set to TXL, TXH, TYL, TYH by writing data to timer and timer latch at the same time. When setting this value, the output of CNTR₀/CNTR₁ pin is initialized to the "H" level.

[During count operation enabled]

By setting the bit 0 or 1 of TXYCON to "0", an "H" interval of TXH or TYH is output first, and after that a "L" level interval of TXL or TYL are output next. These operations are repeated continuously. The PWM output is changed after the underflow by setting a timer value, which is set by writing data to the timer latch only, to TXL, TXH, TYL, TYH.

- Precautions

- Set the double-function port of CNTR₀/CNTR₁ pin to output in this mode.
- This mode is unused in low-speed mode.
- When the PWM "H" interval is set to "00₁₆", PWM output is "L".
- When the PWM "L" interval is set to "00₁₆", PWM output is "H".
- When the PWM "H" interval and "L" interval are set to "00₁₆", PWM output is "L".
- When a PWM "H" interval or "L" interval is set to "00₁₆" at least for a short time, timer X/timer Y interrupt request does not occur.
- When the value set to the timer latch is "00₁₆", the value is undefined since the timer counts down by dummy count operation.

Figure 23 shows the timing chart of the PWM mode.

■ Precautions regarding all modes

• Timer X, timer Y writing control

One of the following operation is selected by bit 3 of TXM or TYM for timer X or timer Y.

Writing data to the corresponding latch and timer at the same time

Writing data to only corresponding latch

When the operation "writing data to only corresponding latch" is selected, the value is set to the timer latch by writing a value to timer X/Y address and a timer is renewed at the next underflow. After releasing a reset, "writing the corresponding latch and timer at the same time" is selected. When a value is written to timer X/Y address, a value is set to a timer and a timer latch at the same time. When "writing data to only corresponding latch" is selected, if writing to a reload latch and an underflow are performed at the same timing, the timer value is undefined.

• Timer X, timer Y read control

In pulse period measurement mode and pulse width measurement mode the timer value cannot be read-out. In all other modes read-out operations without effect to count operations/stops are possible. However, the timer latch value cannot be read-out.

• Precautions regarding the CNTR₀/CNTR₁ active edge switch bit and the INT₀/INT₁ interrupt edge selection bit:

The CNTR₀/CNTR₁ active edge switch bit and the INT₀/INT₁ interrupt edge selection bit settings have an effect also on each interrupt active edge.

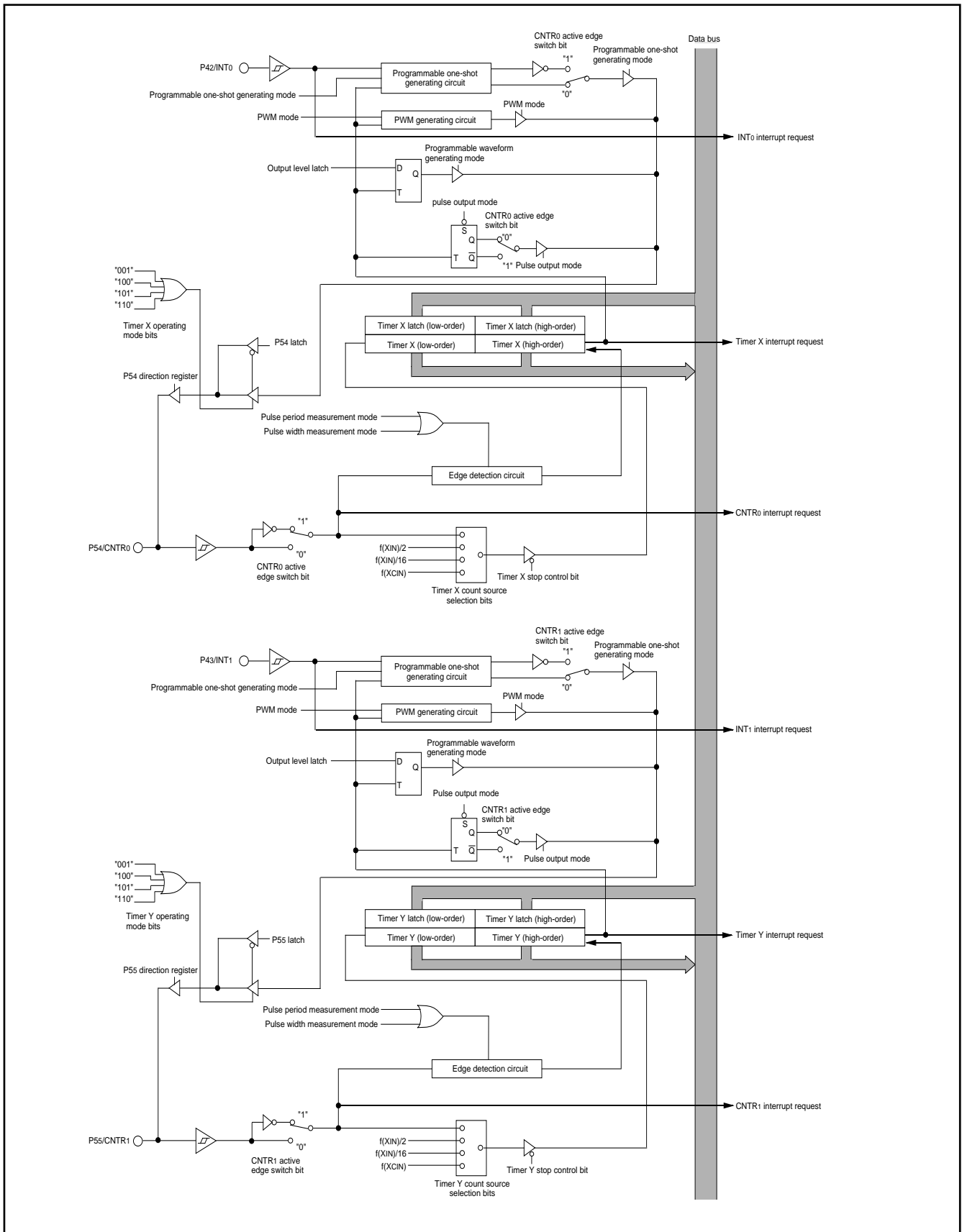

Fig. 15. Block diagram of Timer X and Timer Y

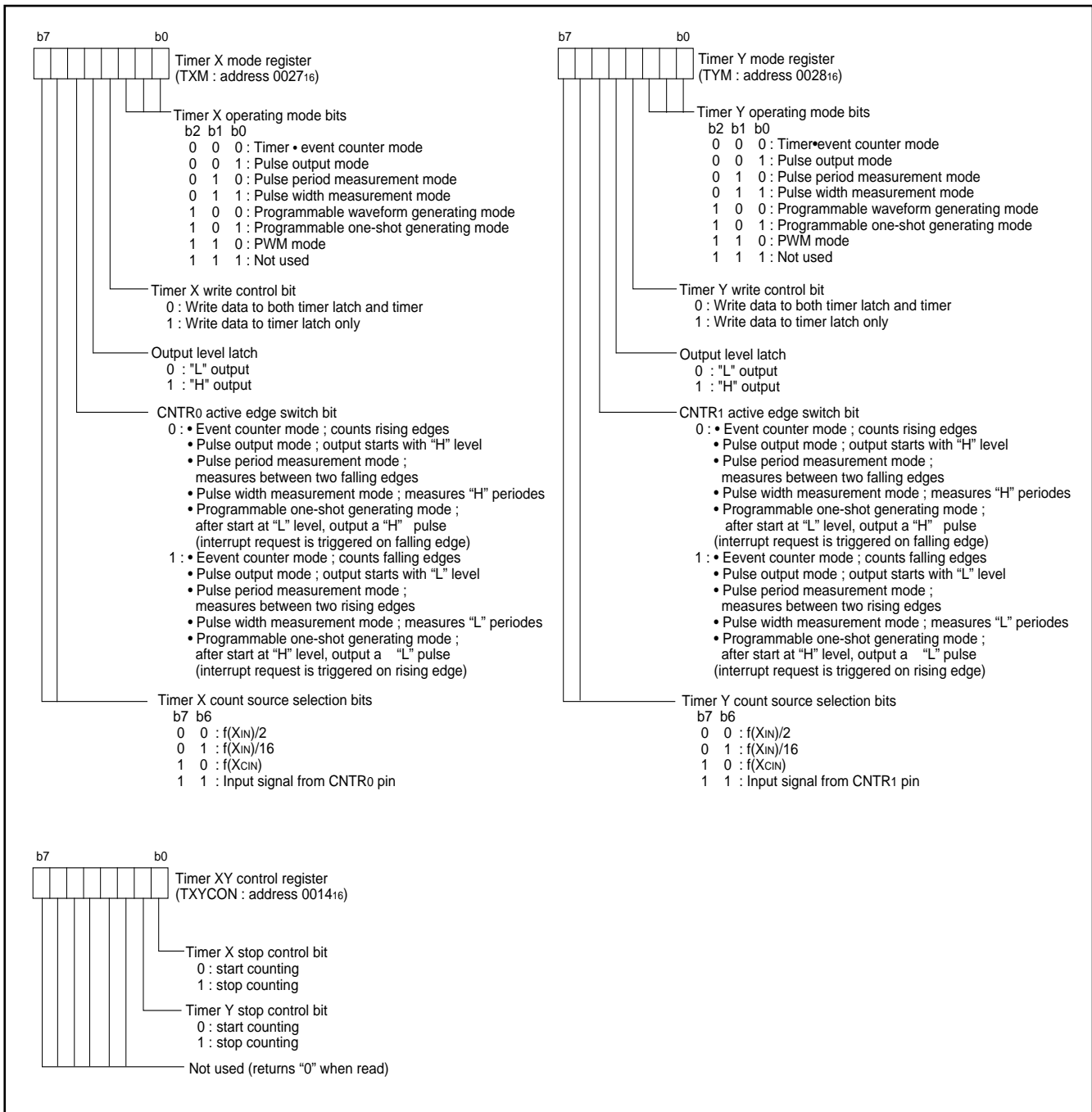

Fig. 16. Structure of Timer X mode register, Timer Y mode register, and Timer XY control register

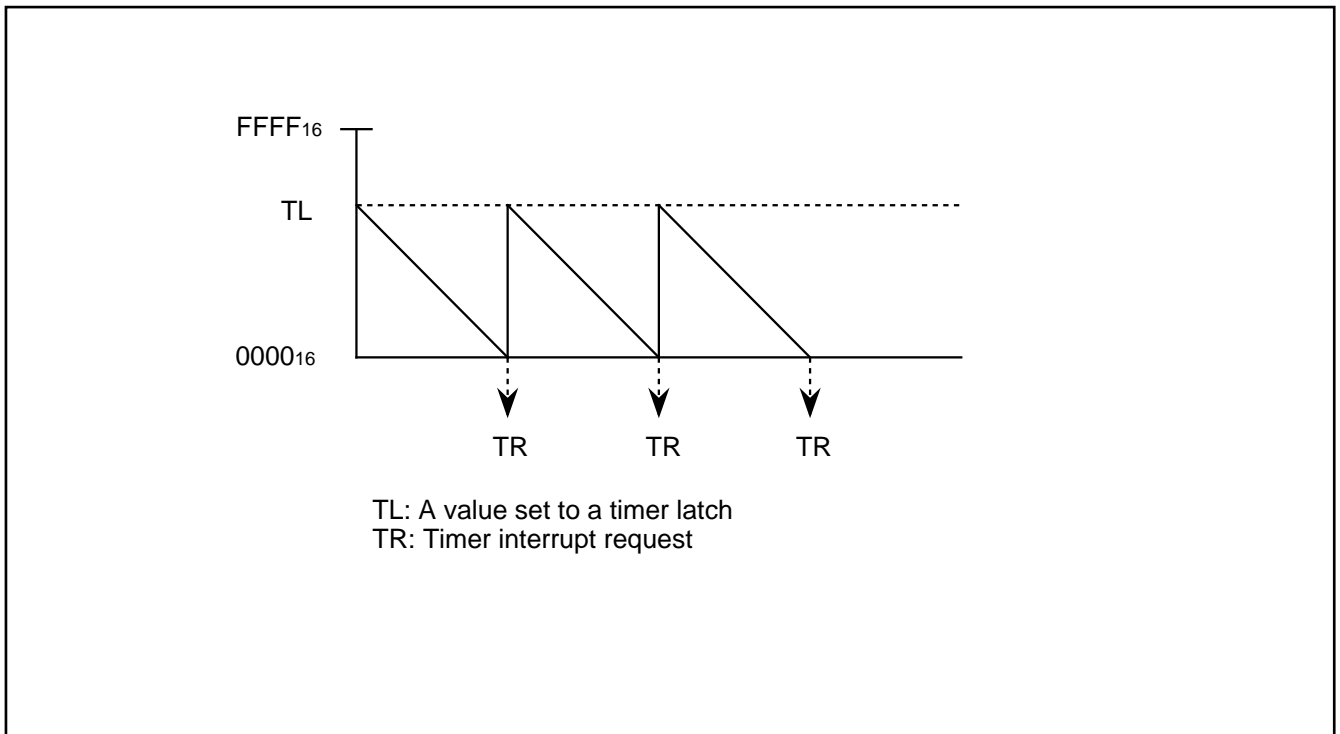

Fig. 17. Timing chart of Timer•Event counter mode

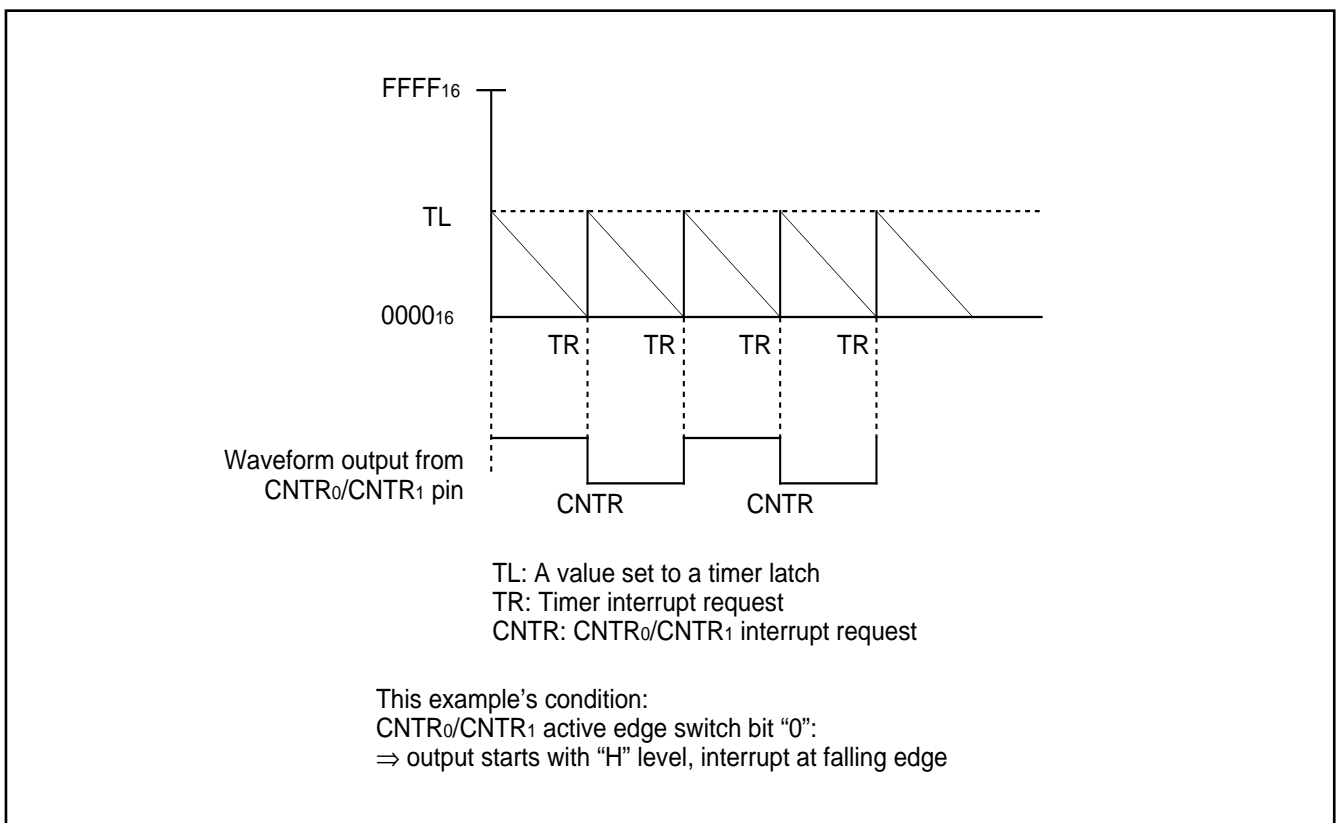

Fig. 18. Timing chart of Pulse output mode

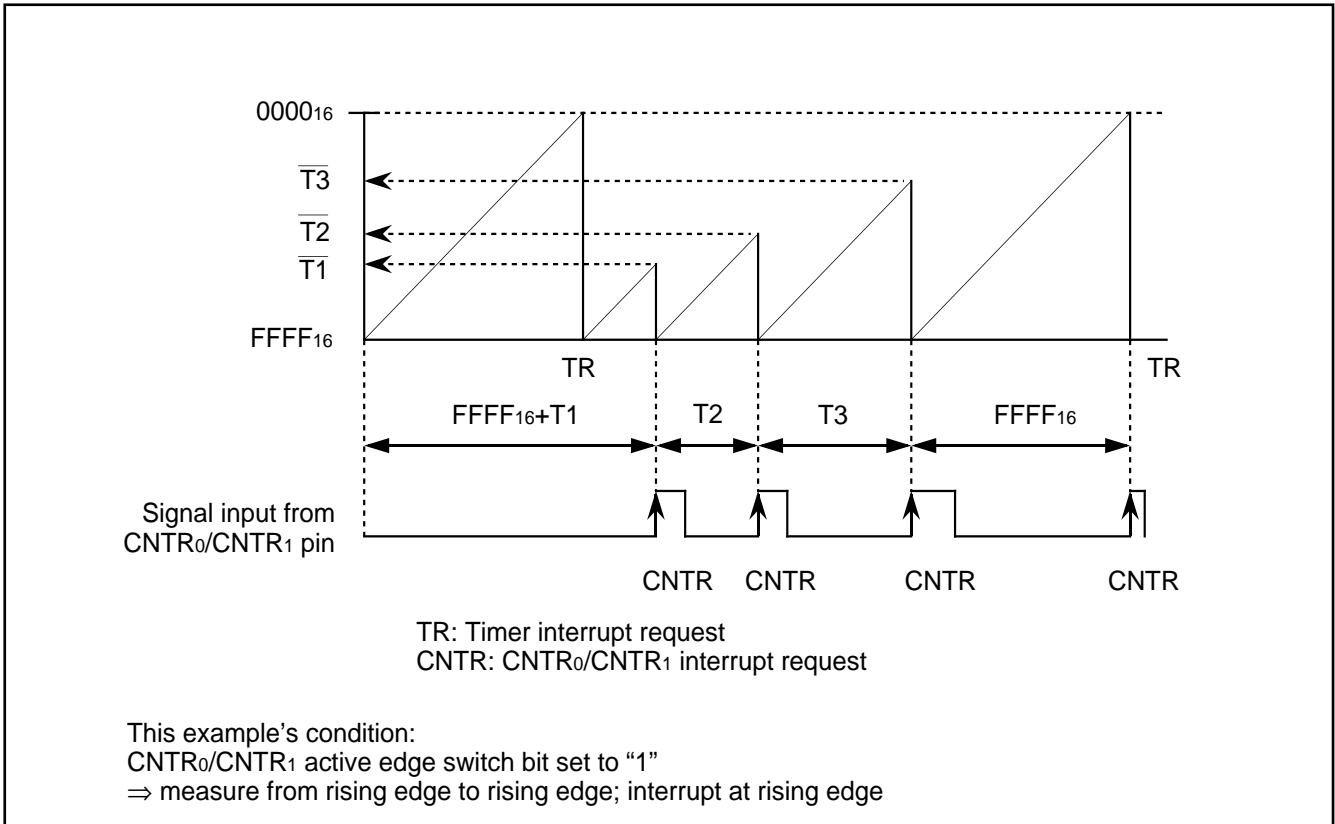

Fig. 19 Timing chart of Pulse period measurement mode

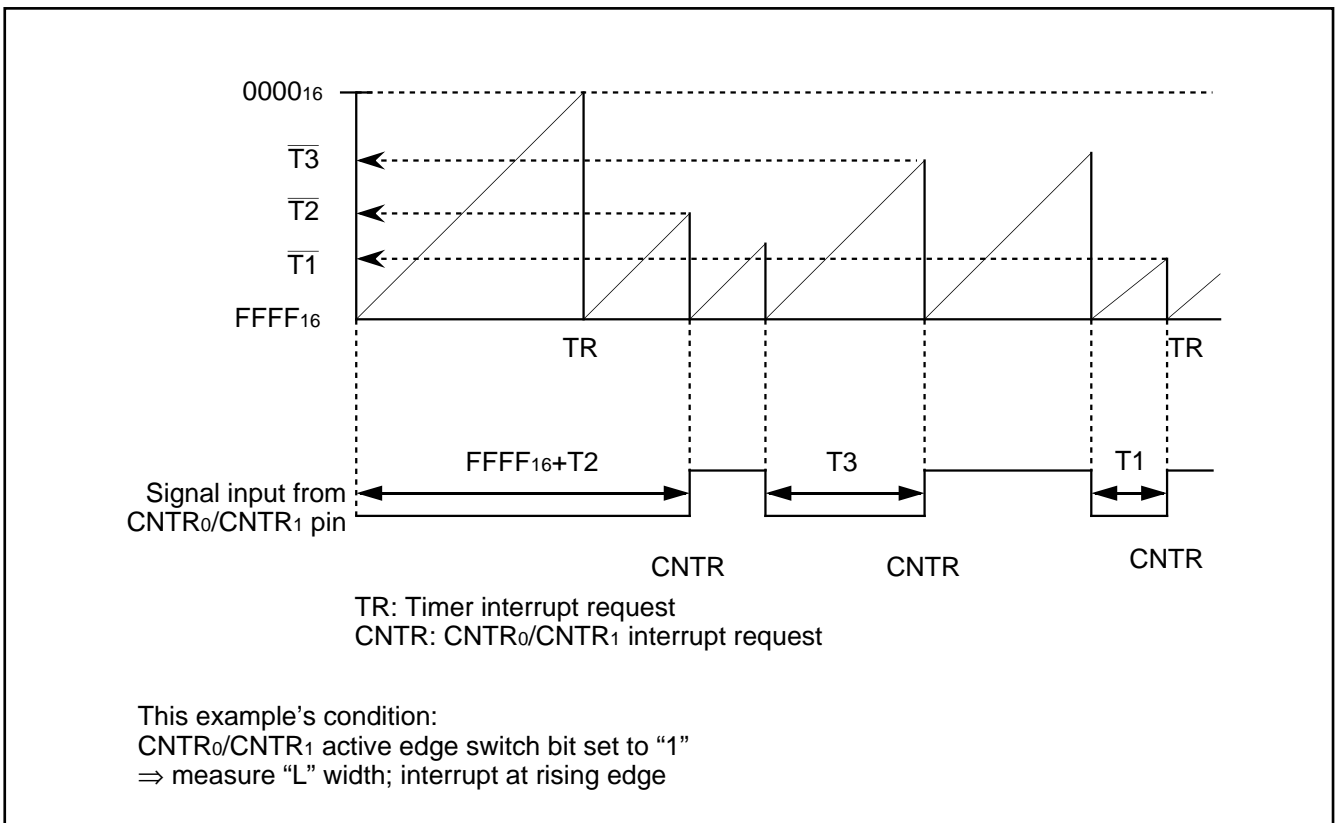

Fig. 20. Timing chart of Pulse width measurement mode

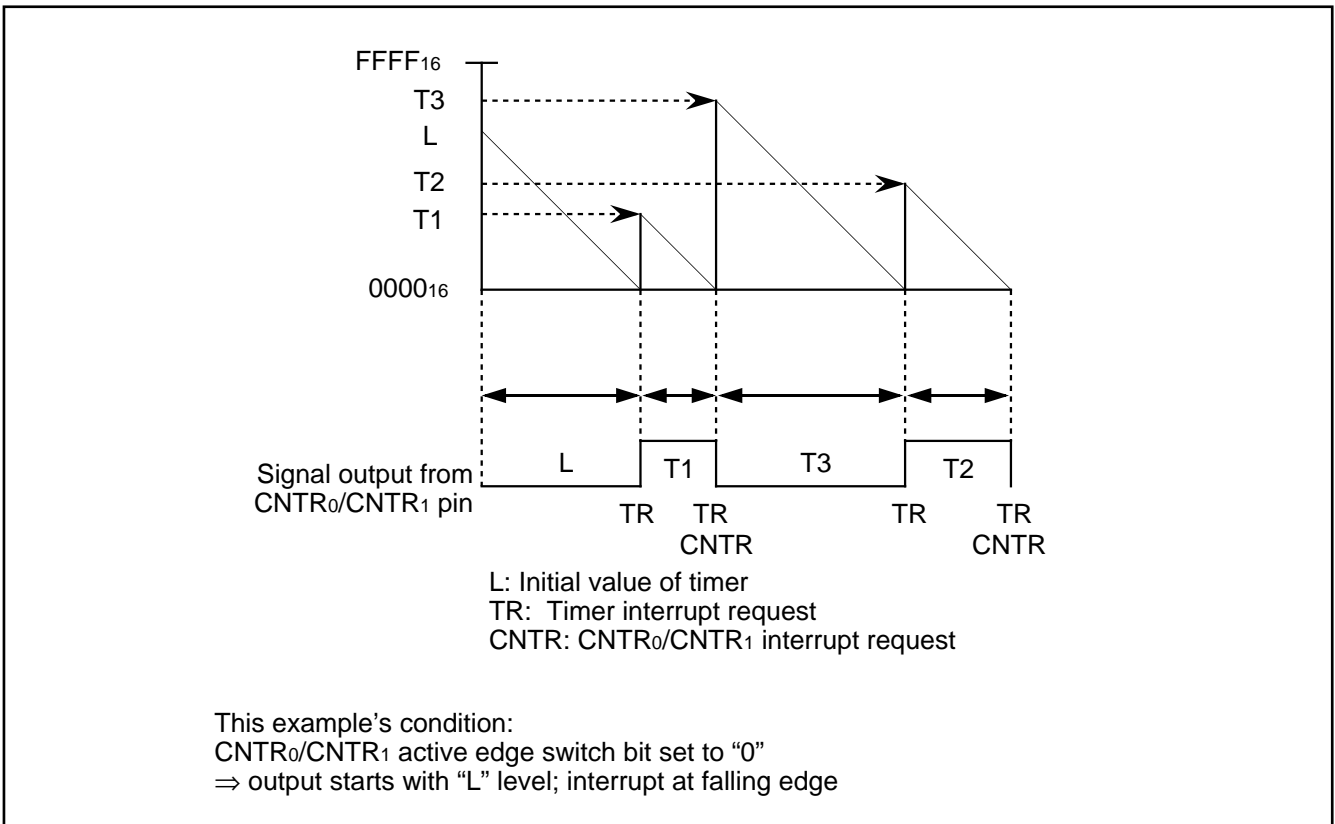

Fig. 21. Timing chart of Programmable waveform generating mode

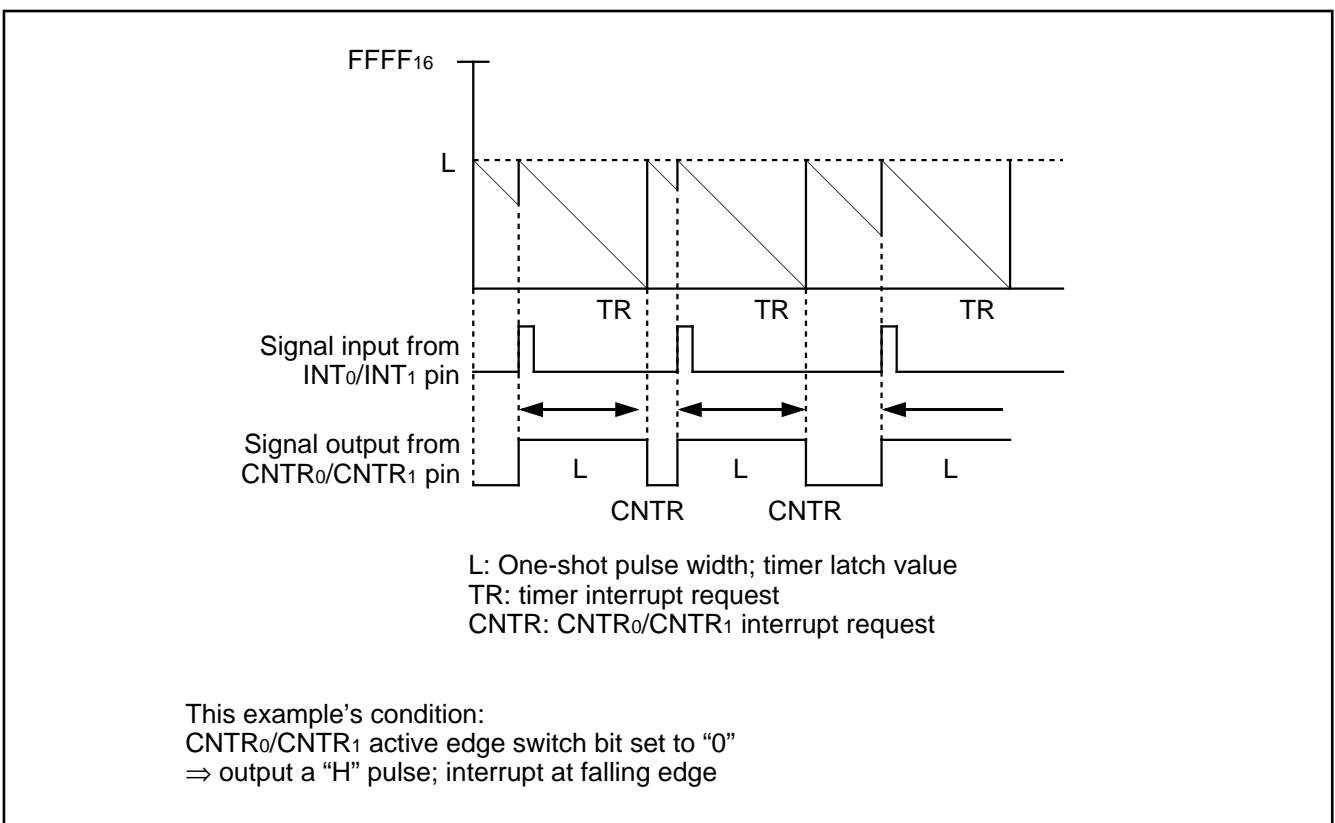

Fig. 22. Timing chart of Programmable one-shot generating mode

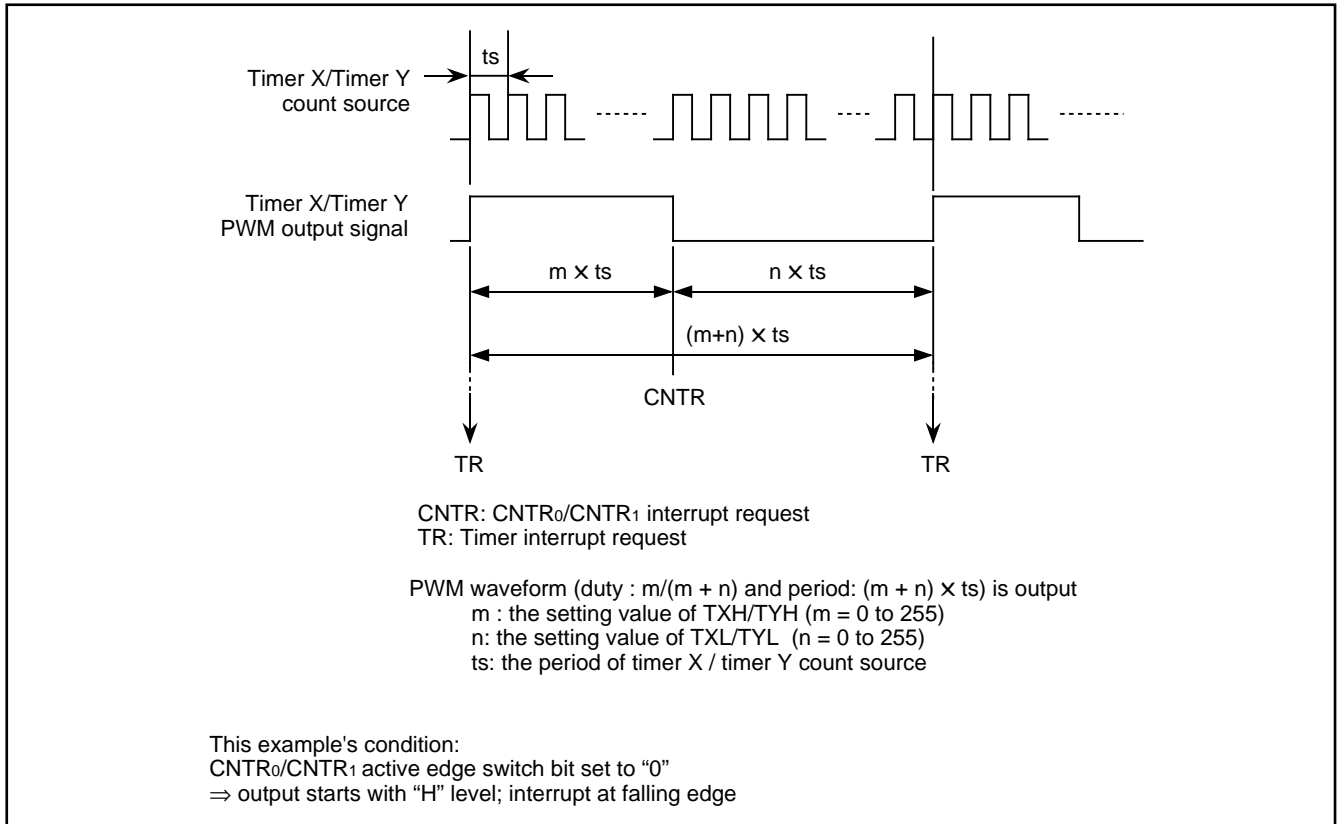

Fig. 23. Timing chart of PWM mode

●Timer 1, Timer 2, Timer 3

Timer 1 to 3 are 8-bit timers for which the count source can be selected through timer 123 mode register.

(1) Timer 2 write control

Timer 2 write control bit (b2) of timer 123 mode register allows to select whether a value written to timer 2 is written to timer latch and timer synchronously or to the timer latch only.

If only the timer latch is written to, the value is set only to the reload-latch by writing a value to the timer address at that time. The content of timer is reloaded with the next underflow. Usually writing operation to the timer latch and timer synchronously is selected. And a value is written to the timer latch and timer synchronously when a value is written to the timer address.

If only the timer latch is written to, it may occur that the value set to the counter is not constant, when the timing with which the reload-latch is written to and the underflow timing is nearly the same.

(2) Timer 2 output control

When timer 2 output (T_{OUT}) is enabled, inverted signals are output from T_{OUT} pin each time timer 2 has underflow. For this reason, set the double-function port of T_{OUT} pin to output mode.

■Precautions on timers 1 to 3

When the count source for timer 1 to 3 is switched, it may occur that short pulses are generated in count signals and that the timer count value shows big changes. When timer 1 output is selected as timer 2 or timer 3 count source, short pulses are generated to signals output from timer 1 through writing timer 1. Due to that, the count values for timer 2 and 3 may change very often.

Therefore, when the count sources for timer 1 to 3 are set, set the values in order starting from timer 1.

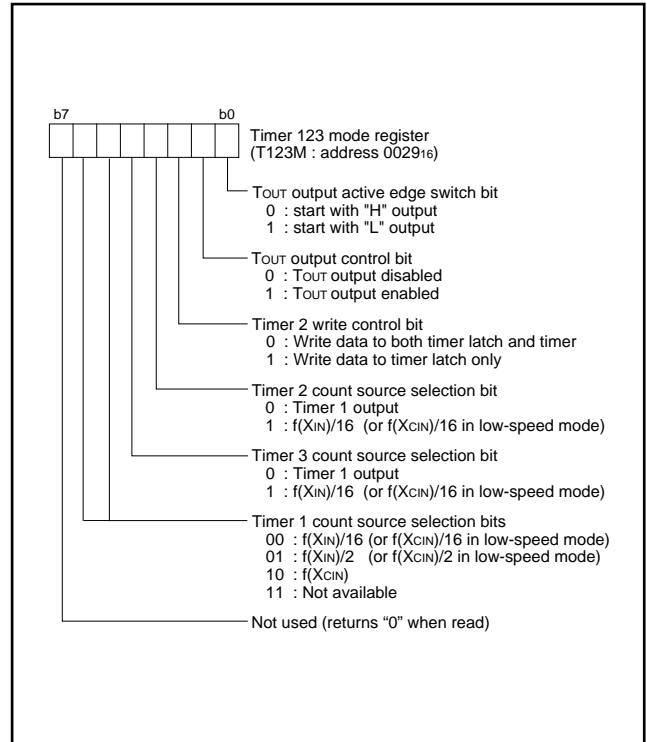

Fig. 24. Structure of Timer 123 mode register

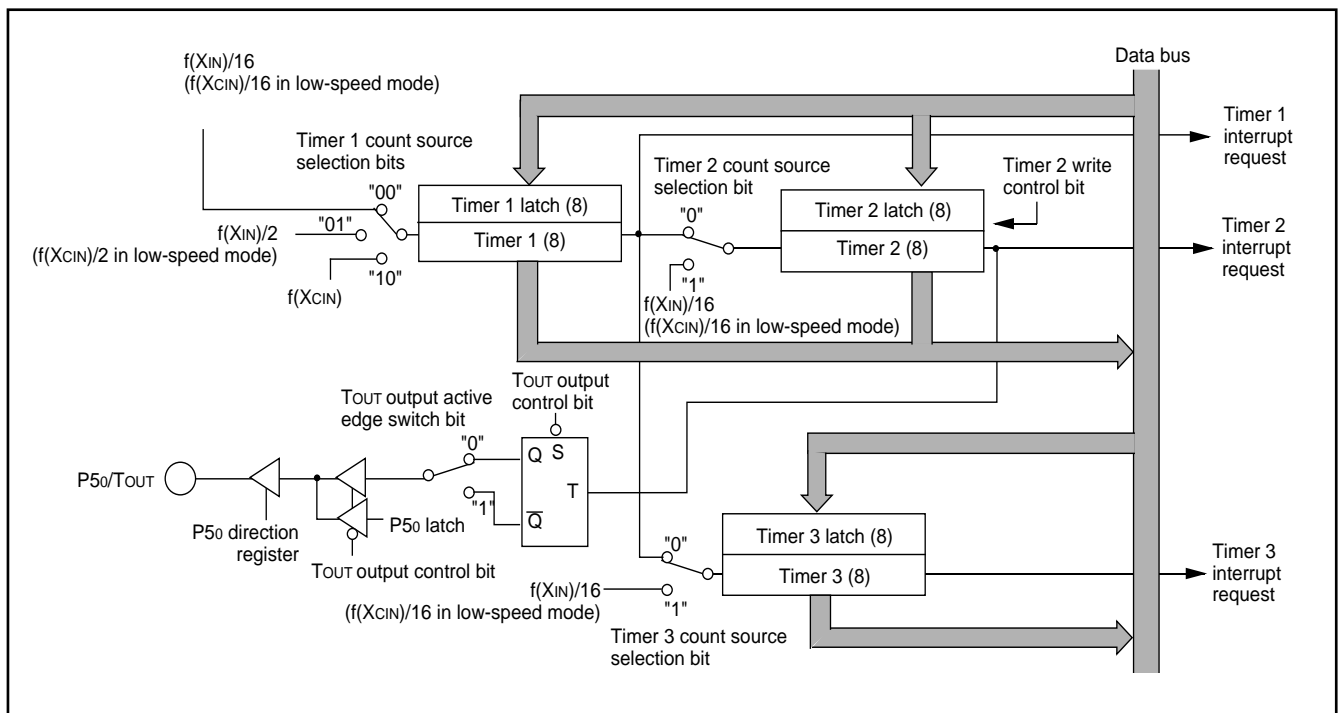

Fig. 25. Block diagram of Timer

●Real time output port

The 3807 group has two on-chip sets of real time output ports (RTP). The two sets of real time output ports consist of two 16-bit timers A and B and eight 8-bit real time port registers. Synchronous to the reloading of timers A and B, the real time port register values are output from ports P8₂ to P8₇, P3₀ and P3₁. The real time port registers consist of 8-bit register 0 to 7. Each port with its corresponding bits is shown in figure 26.

Timer A and timer B have each two 16-bit timer latches. Figure 26 shows the real time port block diagram and figure 27 and 28 show the structure of the real time port control registers 0 to 3.

There are four operating modes for real time ports which are: 8 repeated load mode, 6 repeated load mode, 5 repeated load mode and one-shot pulse generating mode. Each operating mode can be set for timer A and timer B separately. However, switch modes during timer count stop.

(1) 8 repeated load mode

The output operation for each value of the real time port registers 7 to 0 is performed repeatedly in association with an alternate underflow of the corresponding timer latch 1 or 0. The real time port output pointer changes in sequence as a cycle of 8 repeated load operations as "7, 6, 5, 4, 3, 2, 1, 0, 7, 6, 5, 4, 3, 2, 1, 0, 7, 6, 5,"

The initial value at the generation of a start trigger can be specified by setting a value in the output pointer. Figure 29 shows a timing chart of 8 repeated load mode.

(2) 6 repeated load mode

The output operation for each value of real time port registers 5 to 0 is performed repeatedly in association with an alternate underflow of the corresponding timer latch 1 to 0. The real time port output pointer changes in sequence as a cycle of 6 repeated load operations as "5, 4, 3, 2, 1, 0, 5, 4, 3, 2, 1, 0, 5, 4,"

The initial value at the generation of a start trigger can be specified by setting a value in the output pointer. Figure 30 shows a timing chart of the 6 repeated load mode.

(3) 5 repeated load mode

The output operation for each value of real time port registers 4 to 0 is performed repeatedly in association with an alternate underflow of the corresponding timer latch 1 or 0. The real time port output pointer changes in sequence as a cycle of 5 repeated load operations as "4, 3, 2, 1, 0, 4, 3, 2, 1, 0, 4, 3, 2, 1," The initial value at the generation of a start trigger can be specified by setting a value in the output pointer. Figure 31 shows a timing chart of the 5 repeated load mode.

(4) One-shot pulse generation mode

The output operation for each value of real time port registers 2 to 0 is performed only once in association with trigger generation and an underflow of timer latch 1 or 0. After a trigger is generated, the value of real time port register 1 is output from the real time output port and the output pointer value becomes "000₂". At each underflow of the timer, the each value of real time port registers 0 and 2 is output in ascending sequence, then the operation is completed.

After completion of the operation, the value of real time port register 2 is continuously output from the real time output port and the output pointer value continues to be "001₂" until the next start trigger is

generated. In this condition, the real time port function is in the wait status.

When this mode is selected, the pointer value is not changed by writing a value into the output pointer. If external trigger is specified as trigger selection when this mode is selected, a rising and falling double edge trigger is generated regardless of the contents of the INT₄ interrupt source bit (b7) of the interrupt edge selection register.

Figure 32 shows a timing chart of the one-shot pulse generation mode.

(5) Selection of timer interrupt mode

The timer is a count-down system. The contents of the timer latch are reloaded by the count pulse subsequent to the moment when the contents of the counter becomes "0000₁₆". At the same time, the interrupt request bit corresponding to each timer is set to "1." The interrupt request corresponding to the value of the real time port output pointer can also be controlled. For controlling the interrupt request bit, refer to the item pertaining to the timer interrupt mode selection bit of the real time port control register 1,2 shown in figure 27 and 28.

(6) Switch of timer count source

The timer A and the timer B can select the system clock ϕ divided by 2 or 16 as a count source with the timer A, B count source selection bit (b0) of real time port control register 0.

[Timer latches]

Each of the timer A and the timer B has two 16-bit timer latches. Data is written into the 8 low-order bits and the 8 high-order bits in this order. When the high-order side has been written, the next latch is automatically specified. The writing pointer changes in sequence as "1, 0, 1, 0, 1," The timer latch to be written first can be specified by setting the timer writing pointer. Data is not written directly into the timer A and the timer B. When reading the contents of the timer, the count value at that point of time is read. Read the high-order side first and then the low-order side. The low-order side value is read with the same timing as that for the high-order side value and held at the timer read latch. The data held state is released by reading the low-order side. At a reload operation of the timer A or the timer B. Timer latch 1 is reloaded as the initial value after a trigger is generated. After that, the timer latch is reloaded in sequence as "0, 1, 0, 1," The timer latch value cannot be read out.

[Start trigger]

The operation of the real time port is started by a start trigger. When a start trigger is generated, the value of the real time port register specified by the output pointer (the value of real time port register 1 in the one-shot pulse generation mode) is output from the real time output port.

The value of timer latch 1 is reloaded into the timer A or the timer B and the timer count A, B source stop bit is released, so that the timer count is started.

After that, when the timer underflows, data is transferred from the real port register to the real time output port.

As a start trigger, either internal trigger or external trigger can be selected by the timer A start trigger selection bit (b2) or timer B start trigger selection bit (b5) of real time port control register 0.

When the internal trigger is selected, a start trigger is generated by an input signal of the INT4 pin. The start trigger becomes a falling edge when the INT4 interrupt edge selection bit is "0" and a rising edge when this bit is "1".

When the external trigger is selected in the one-shot pulse generation mode, the start trigger becomes a rising/falling double edge trigger regardless of the contents of the INT4 interrupt edge selection bit.

[Real time port registers] RTP

The data to be output to real time ports is written into 8 real time port registers 0 to 7. The correspondence between each bit of real time port registers and each port output is as follows :

- P31: bit 7 of real time port registers 7 to 0
- P30: bit 6 of real time port registers 7 to 0
- P87: bit 5 of real time port registers 7 to 0
- P86: bit 4 of real time port registers 7 to 0
- P85: bit 3 of real time port registers 7 to 0
- P84: bit 2 of real time port registers 7 to 0
- P83: bit 1 of real time port registers 7 to 0
- P82: bit 0 of real time port registers 7 to 0

It can be selected for each bit by real time port control register 3 whether the output of each port is to be used as an ordinary I/O port or a real time port output.

[Real time port data pointer]

It can be optionally specified by the real time port data pointers A or B and the real time port data pointer A or B switching bit in which real time port register the output data is to be set or from which real time port register the data output is to be started.

When writing output data into the real time port register, set the real time port data pointer A, B switch bit to "0" (select the R/W pointer) and also write a value into the 3 bits of the real time port data pointers A, B. With this, the real time port register for writing will be specified. After that, when a value is written into the real time port register (address 002A16), the data is written into the specified real time port register and also the R/W pointer value is automatically decreased by 1. Then writing data is enabled into the next real time port register.

A value of "0002" to "1112" can be set into the R/W pointer regardless of the operating mode specified by the timer A, B operating mode selection bit, and the R/W pointer value is automatically decreased by 1 by writing data into the real time port register. However, when a value becomes "0002", the R/W pointer value is decreased by 1 in the numeral range of stages to be used in each operating mode unless the R/W pointer is set again at the subsequent write operation to the real time port register. When "1112 (=7)" is set in the R/W pointer, the R/W pointer operation in each selected mode is as follows :

- During 8 repeated load mode 7→6→5→4→3→2→1→0→7→6→5...
- During 6 repeated load mode 7→6→5→4→3→2→1→0→5→4→3...
- During 5 repeated load mode 7→6→5→4→3→2→1→0→4→3→2....
- During one-shot pulse generation mode
7→6→5→4→3→2→1→0→2→1→0....

When reading the real time port register, set the real time port data pointer A, B switch bit to "0" (select the R/W pointer) and also writing a value into the 3 bits of the real time port data pointer A, B to specify the real time port register for reading. After that, the value of the

specified real time port register can be read by reading the real time port register (address 002A16). In this case, however, the R/W pointer value is not counted down automatically. Accordingly, to read another real time port register, rewrite the R/W pointer beforehand.

To specify a read port register to be output to the real time output port, set the real time port data pointer A, B switch bit to "1" (select an output pointer) and also set a value in the 3 bits of the real time port data pointer A or B.

When a start trigger is generated, data is output beginning with the real time port register set in the output pointer and the output pointer value is automatically decreased by 1.

At each underflow of the timer A or timer B, the output pointer value is automatically decreased by 1. Regarding the case of the one-shot pulse generation mode, however, refer to the item pertaining to the one-shot pulse generation mode.

When the real time port data pointer A to B has been read, only the output pointer can be read.

■Notes regarding all modes

- When the trigger is generated again during timer count operation, the operation is started from the beginning. In this case, put an interval of 3 cycles or more between the generation of a trigger and the generation of the next trigger. If the generation of the next trigger occurs almost concurrently with the underflow timing of the timer, the next real time output may not be performed normally.
- To stop the timer count after generation of a start trigger, write "1" in the timer A, B count source stop bit of real time port control register 0 at an interval of 3 cycles or more of the timer count source.
- To change the contents of the real time port data pointer A, B switch bit, the real time port data pointer must be specified simultaneously. Therefore, use the LDM/STA instruction instead of the SEB/CLB instruction.
- If the timer A, B count source stop bit is changed ("1"→"0") by a start trigger between the read operation and the write operation of a read-modify-write instruction such as the SEB instruction which is used in real time port control register 0, the timer count will stop, having an effect on the real time output.
An maximum interval of 2 cycles of the count source is required before the timer A, B count source stop bit is cleared to "0" which indicates the count operation state after a start trigger is generated regardless of whether the start trigger is an internal trigger or an external trigger.
Accordingly, do not use the read-modify-write instruction for real time port control register 0 in this period. If a write operation for real time port control register 0 with any purpose other than stopping the timer count is performed concurrently with the generation of a start trigger, be sure to use such an instruction for writing "0" into the timer A, B count source stop bit as the LDM/STA instruction.
Even if "0" is written into the timer A, B count source stop bit, the timer count remains in the stop state without change.
- When the timing for writing to the high-order side reload latch is almost equal to the underflow timing, an undesirable value may be set in the timer A or timer B.
- If the real time output port is selected by real time port control register 3 after resetting, "L" is output from this pin until a start trigger is generated.

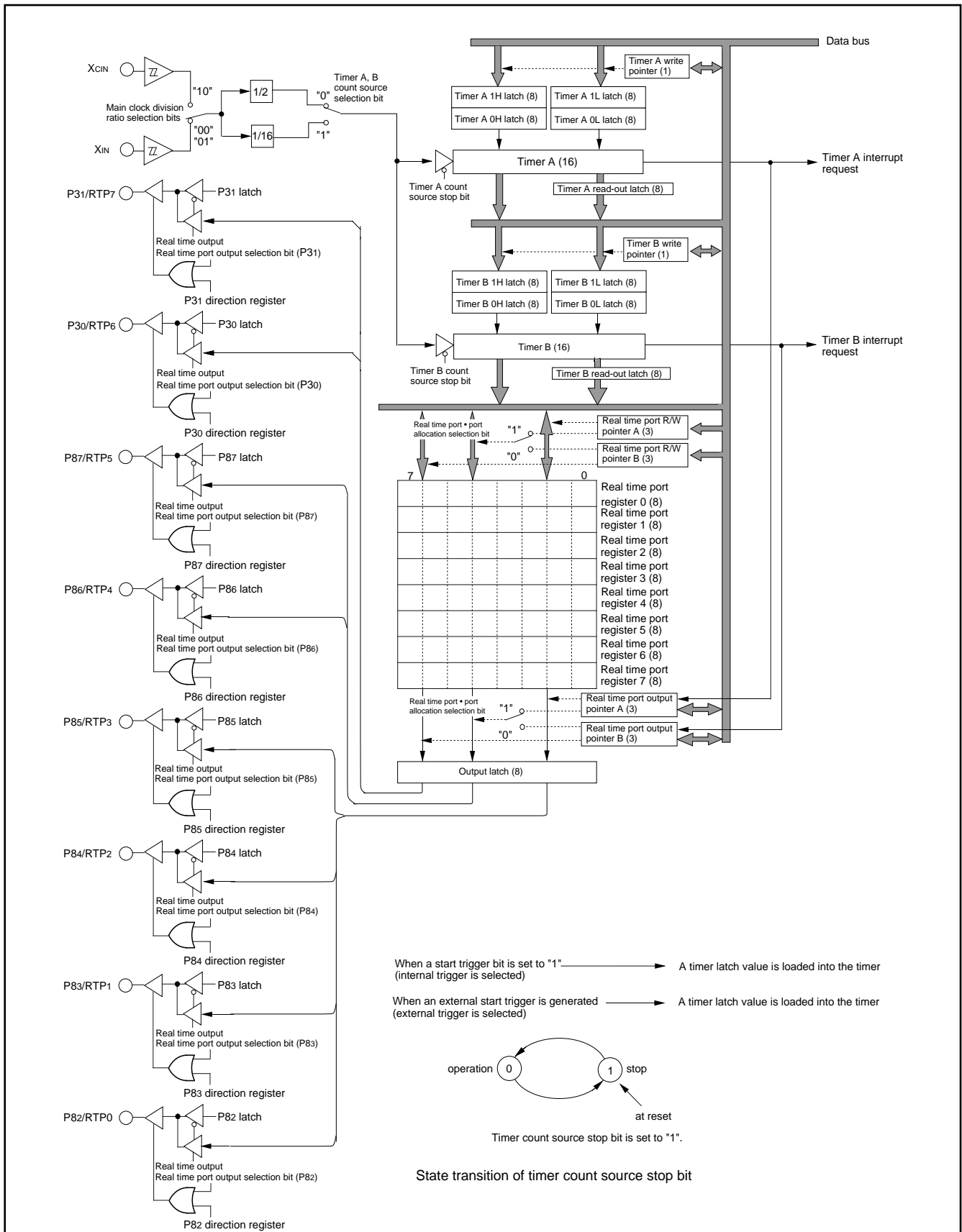

Fig. 26. Block diagram of Real time output port

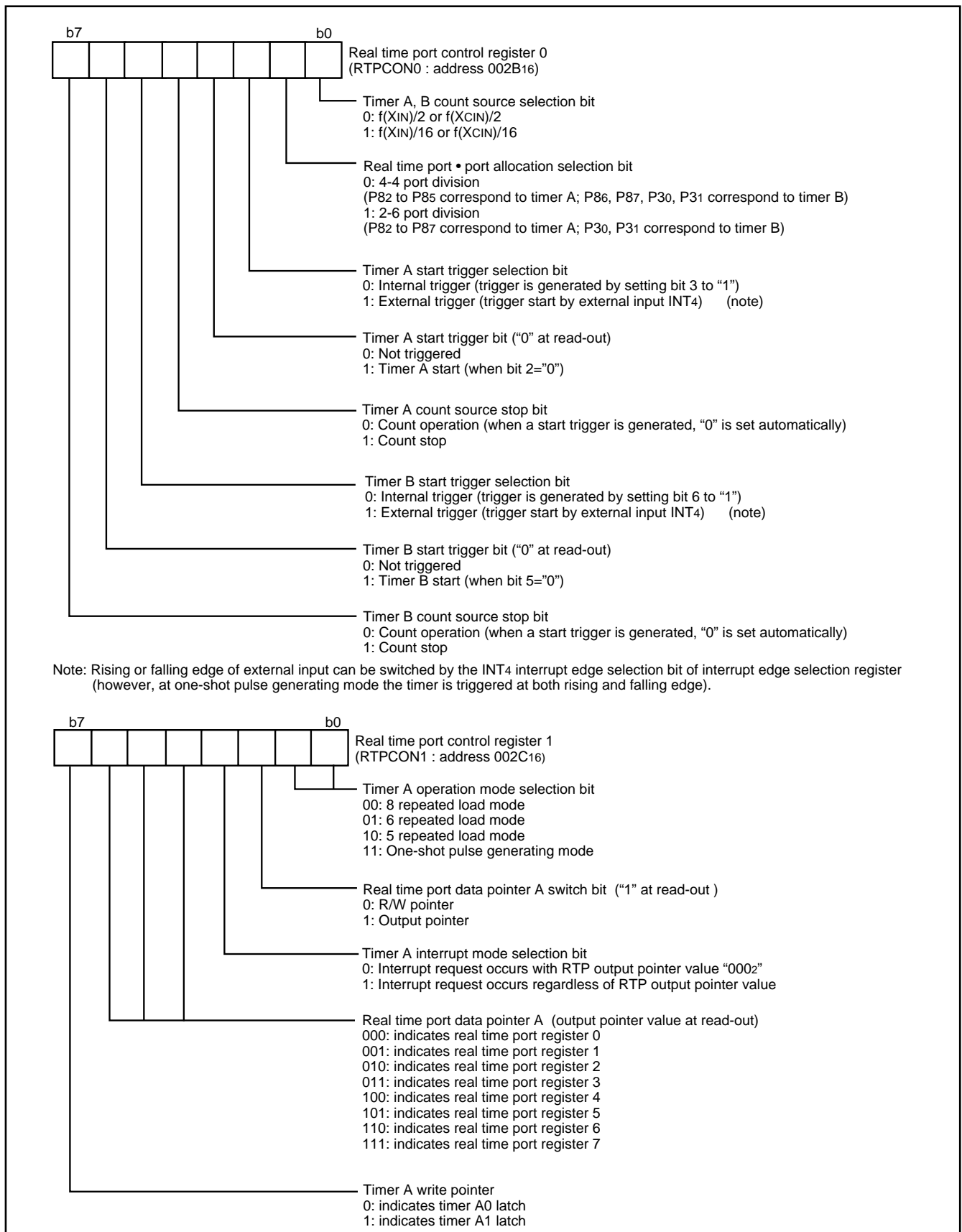

Fig. 27. Structure of Real time output port related register (1)

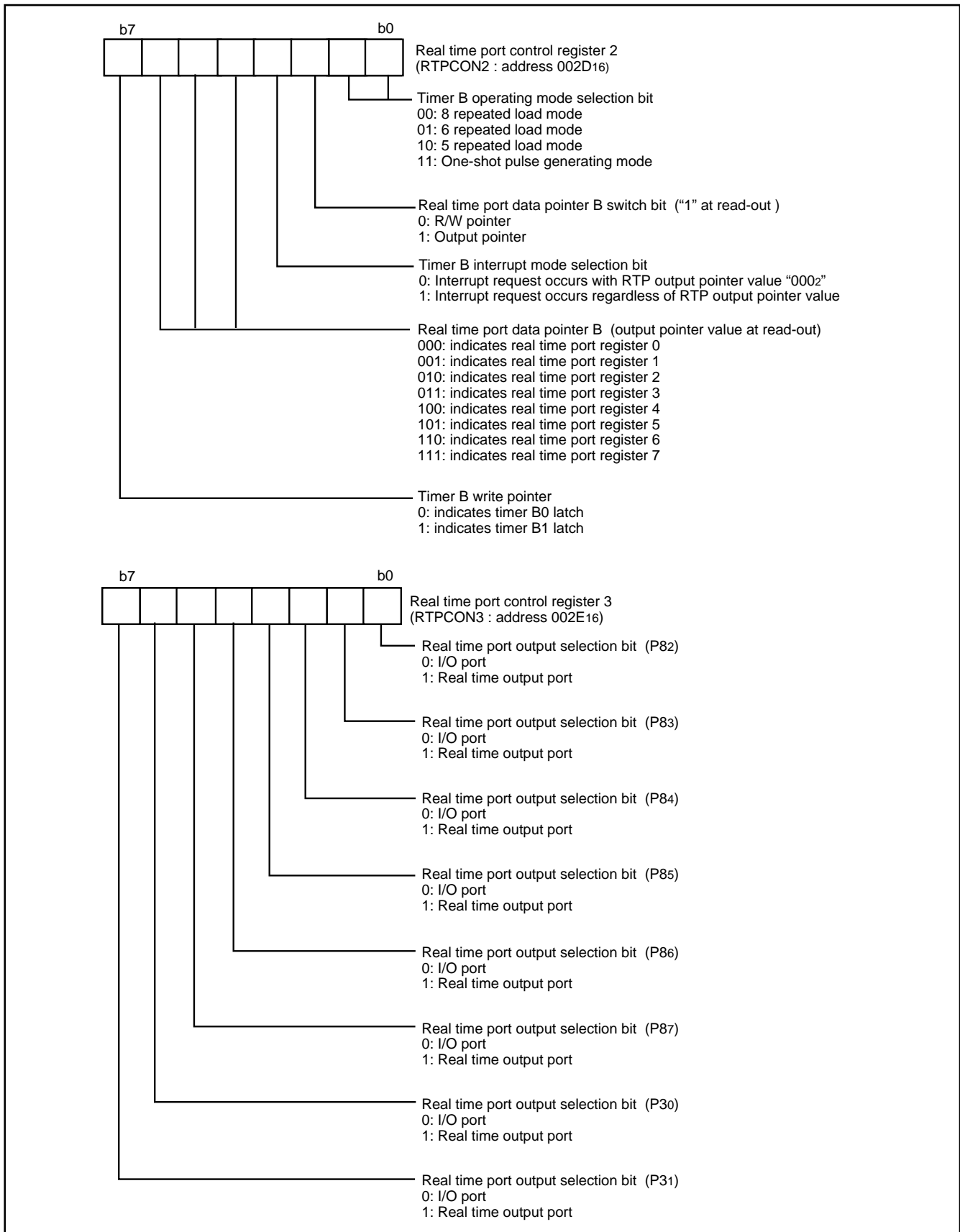

Fig. 28 Structure of Real time output port related register (2)

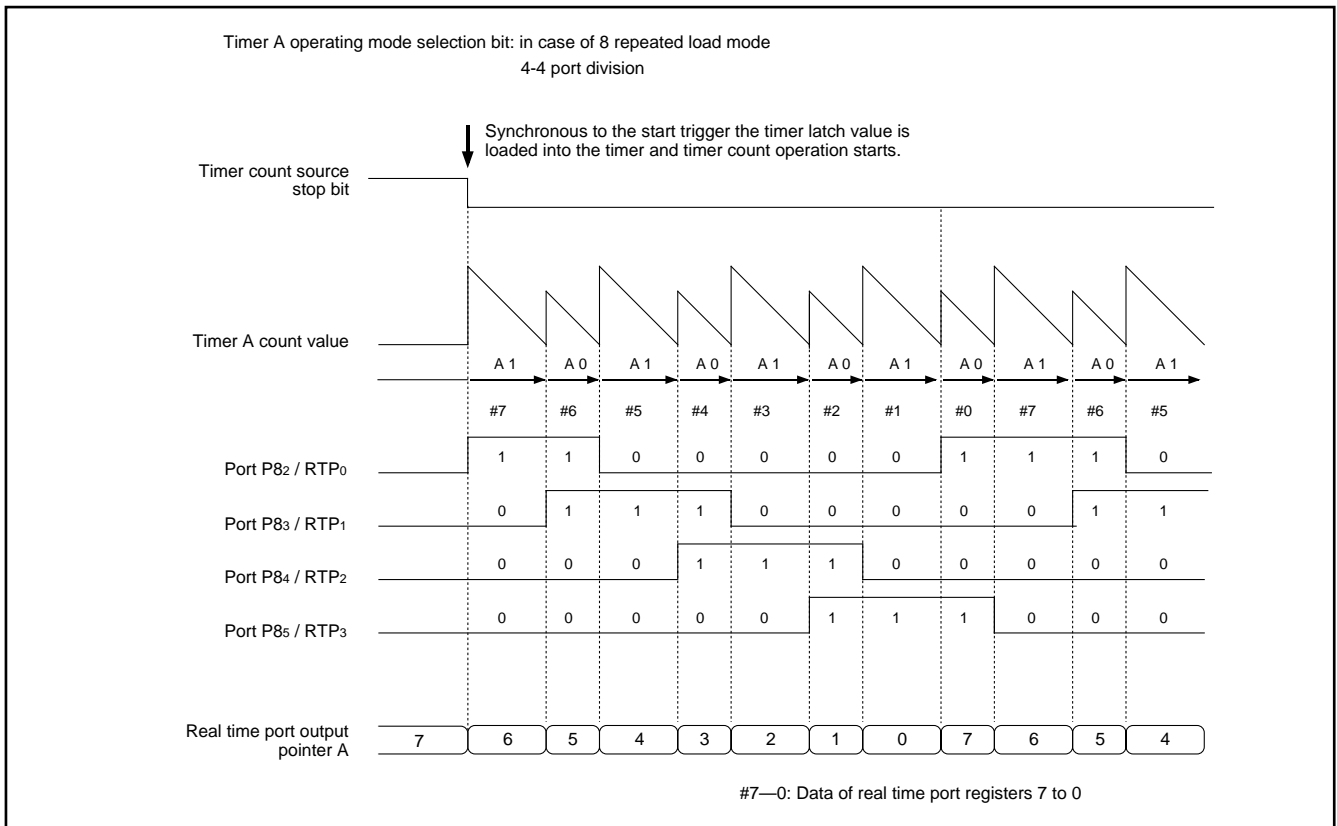

Fig. 29. 8 repeated load mode operation

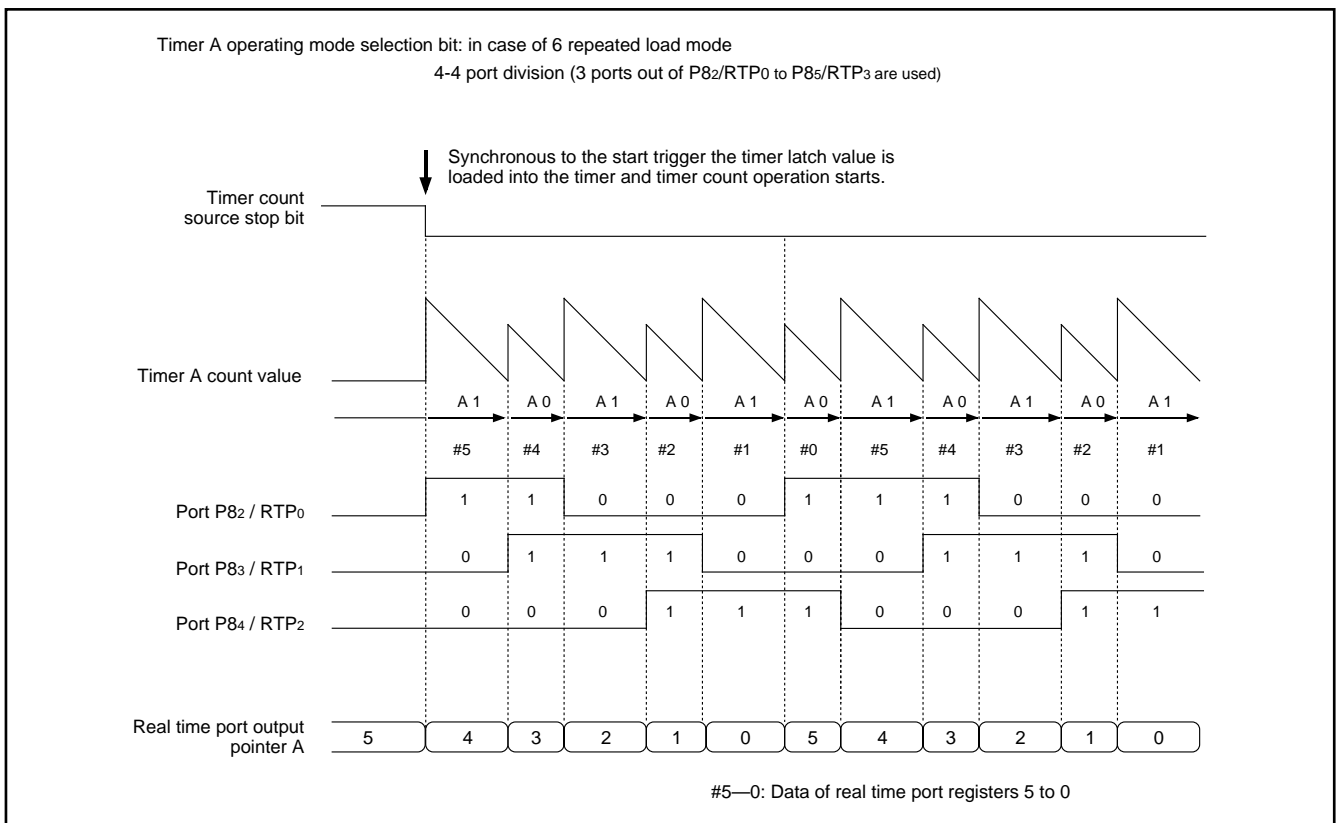

Fig. 30. 6 repeated load mode operation

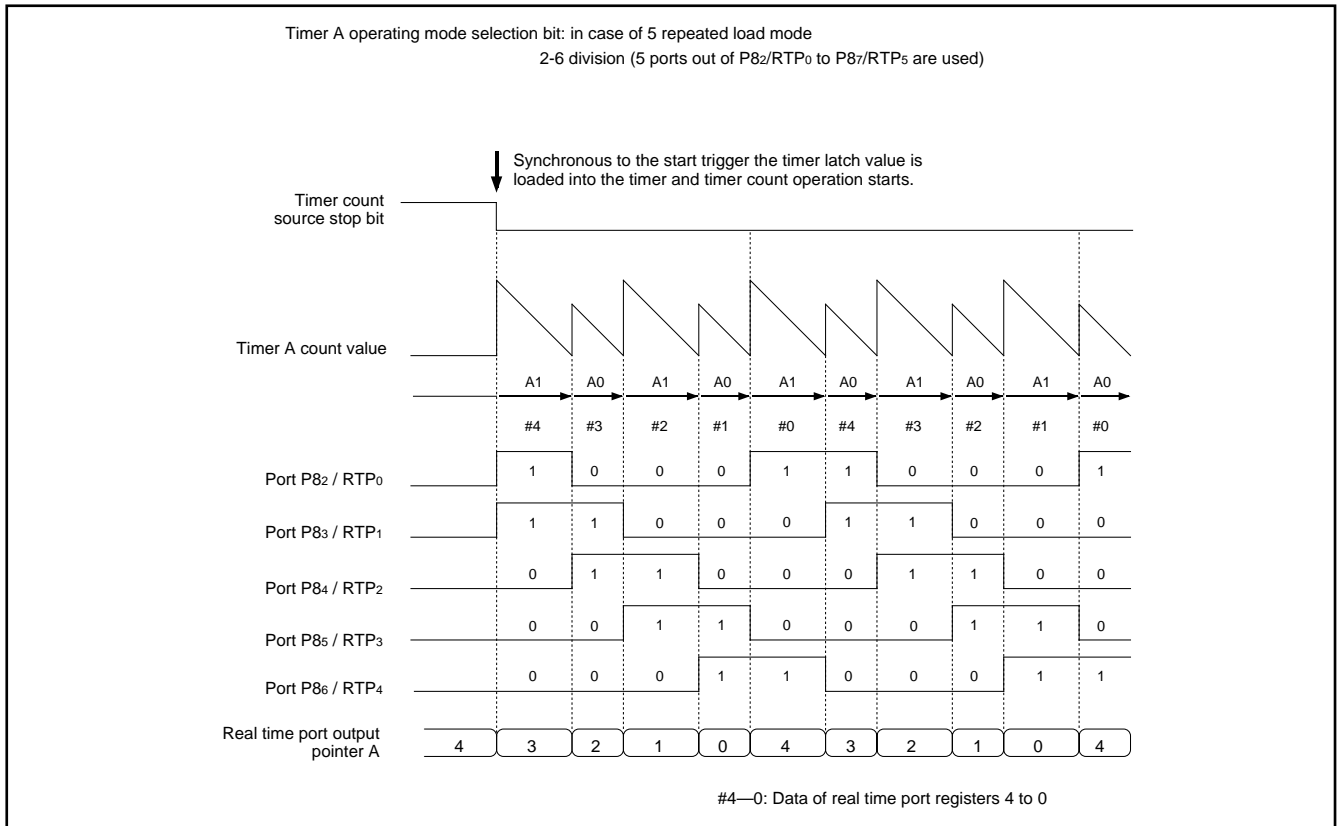

Fig. 31. 5 repeated load mode operation

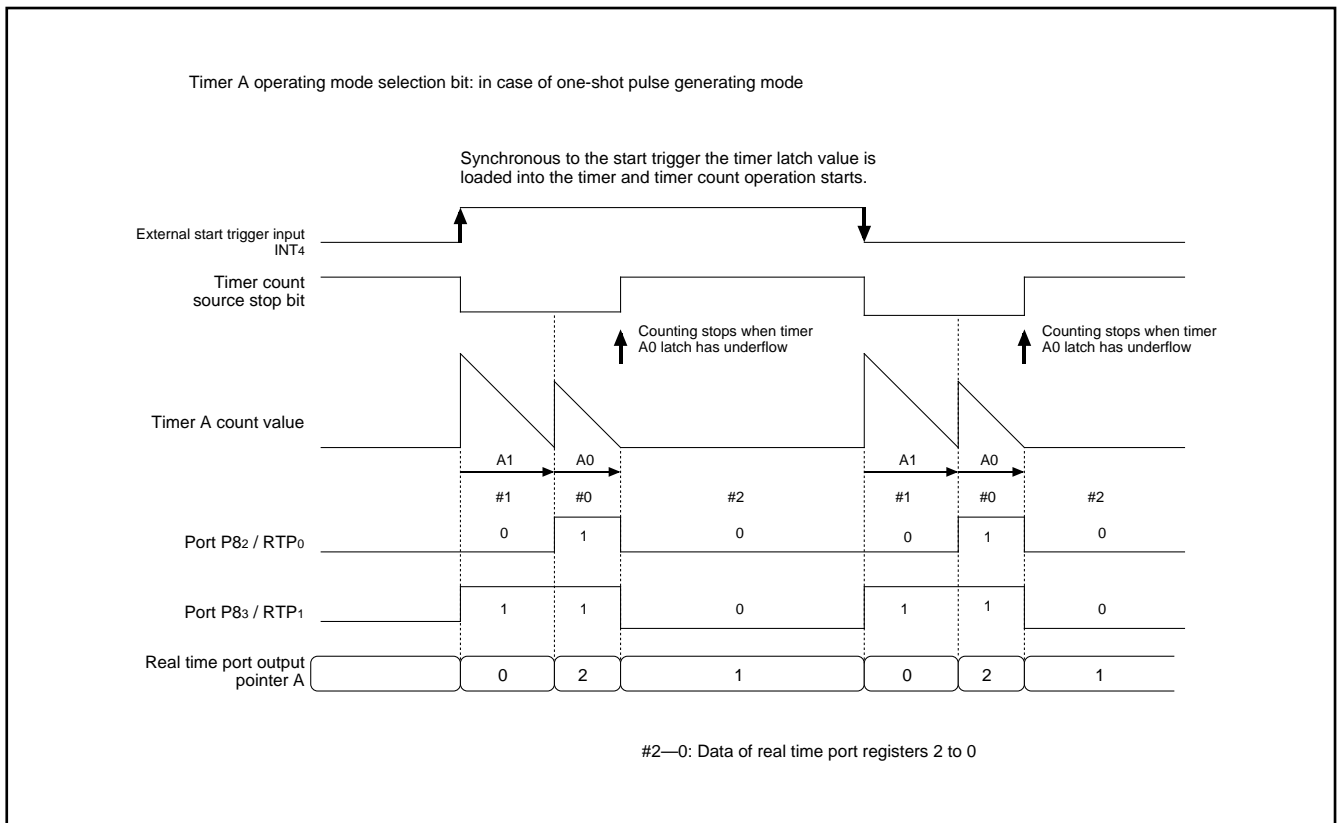

Fig. 32. One-shot pulse generating mode operation

Serial I/O

●Serial I/O1

Serial I/O1 can be used as either clock synchronous or asynchronous (UART) serial I/O. A dedicated timer (baud rate generator) is also provided for baud rate generation during Serial I/O1 operation.

(1) Clock Synchronous Serial I/O Mode

Clock synchronous serial I/O1 mode can be selected by setting the serial I/O1 mode selection bit (b6) of the serial I/O1 control register to "1." For clock synchronous serial I/O, the transmitter and the receiver must use the same clock for serial I/O1 operation. If an internal clock is used, transmit/receive is started by a write signal to the Transmit/Receive buffer register (TB/RB) (address:0018₁₆).

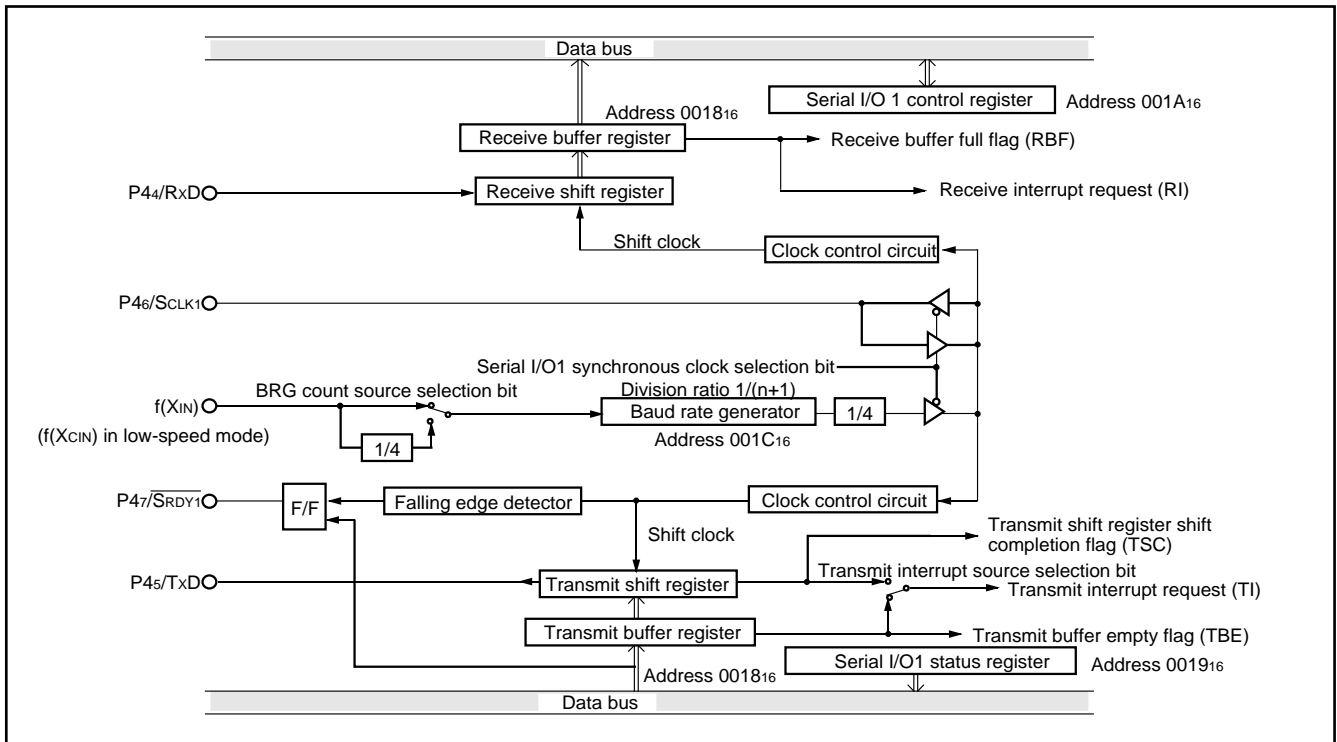

Fig. 33. Block diagram of clock synchronous serial I/O1

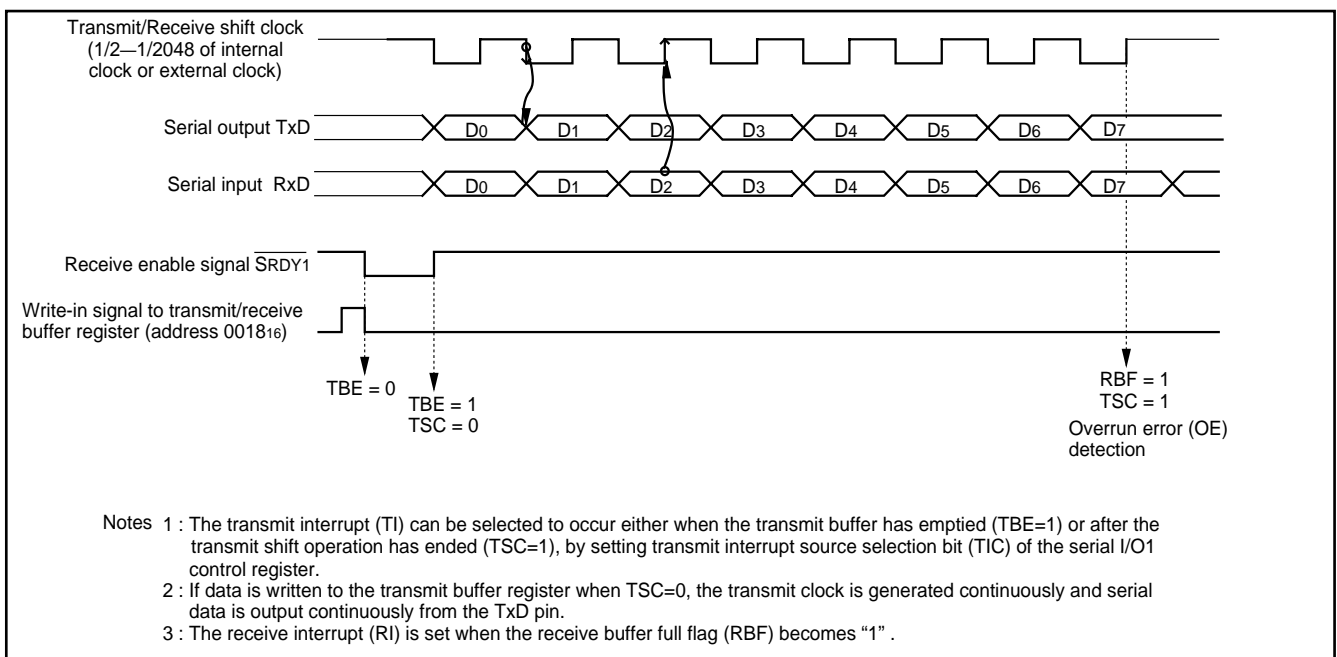

Fig. 34. Operation of clock synchronous serial I/O1 function

(2) Asynchronous Serial I/O (UART) Mode

Asynchronous serial I/O1 mode (UART) can be selected by clearing the Serial I/O1 mode selection bit (b6) of the Serial I/O1 control register to "0." Eight serial data transfer formats can be selected and the transfer formats used by a transmitter and receiver must be identical.

The transmit and receive shift registers each have a buffer (the two buffers have the same address in memory). Since the shift register cannot be written to or read from directly, transmit data is written to the transmit buffer, and receive data is read from the receive buffer. The transmit buffer can also hold the next data to be transmitted, and the receive buffer can hold a character while the next character is being received.

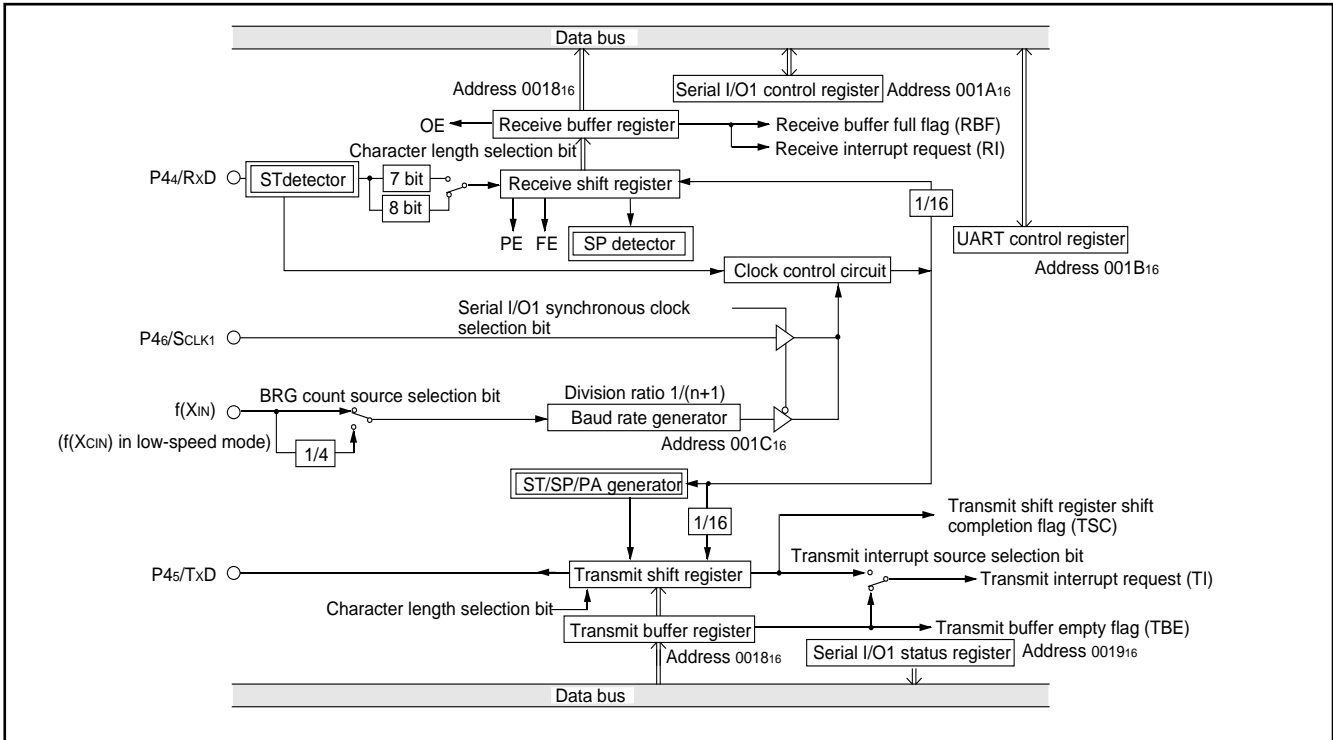

Fig. 35. Block diagram of UART serial I/O1

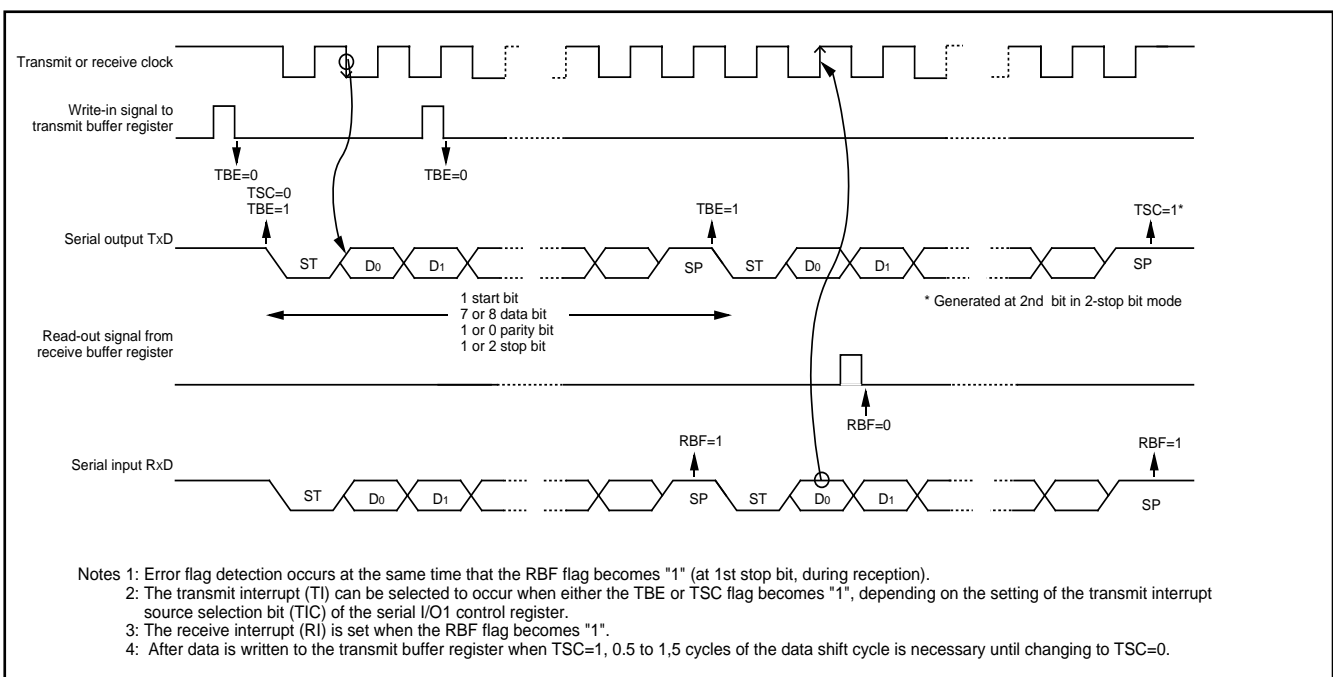

Fig. 36. Operation of UART serial I/O1 function

[Transmit Buffer Register/Receive Buffer Register] TB/RB (0018₁₆)

The transmit buffer and the receive buffer are located in the same address. The transmit buffer is write-only and the receive buffer is read-only. If a character bit length is 7 bits, the MSB of data stored in the receive buffer is "0".

[Serial I/O 1 Status Register] SIO1STS (0019₁₆)

The read-only serial I/O1 status register consists of seven flags (b0 to b6) which indicate the operating status of the serial I/O1 function and various errors. Three of the flags (b4 to b6) are only valid in UART mode. The receive buffer full flag (b1) is cleared to "0" when the receive buffer is read.

The error detection is performed at the same time data is transferred from the receive shift register to the receive buffer register, and the receive buffer full flag is set. A writing to the serial I/O1 status register clears all the error flags OE, PE, FE, and SE (b3 to b6, respectively). Writing "0" to the serial I/O1 enable bit (SIOE : b7 of the serial I/O1 control register) also clears all the status flags, including the error flags.

All bits of the serial I/O1 status register are initialized to "0" at reset, but if the transmit enable bit (b4) of the serial I/O1 control register has been set to "1", the transmit shift register shift completion flag (b2) and the transmit buffer empty flag (b0) become "1".

[Serial I/O1 Control Register] SIO1CON (001A₁₆)

The serial I/O1 control register contains eight control bits for serial I/O1 functions.

[UART Control Register] UARTCON (001B₁₆)

The UART control register consists of four control bits (b0 to b3) which are valid when asynchronous serial I/O is selected and set the data format of an data transfer. One bit in this register (b4) is always valid and sets the output structure of the P45/TxD pin.

[Baud Rate Generator] BRG (001C₁₆)

The baud rate generator determines the baud rate for serial transfer. With the 8-bit counter having a reload register the baud rate generator divides the frequency of the count source by 1/(n+1), where n is the value written to the baud rate generator.

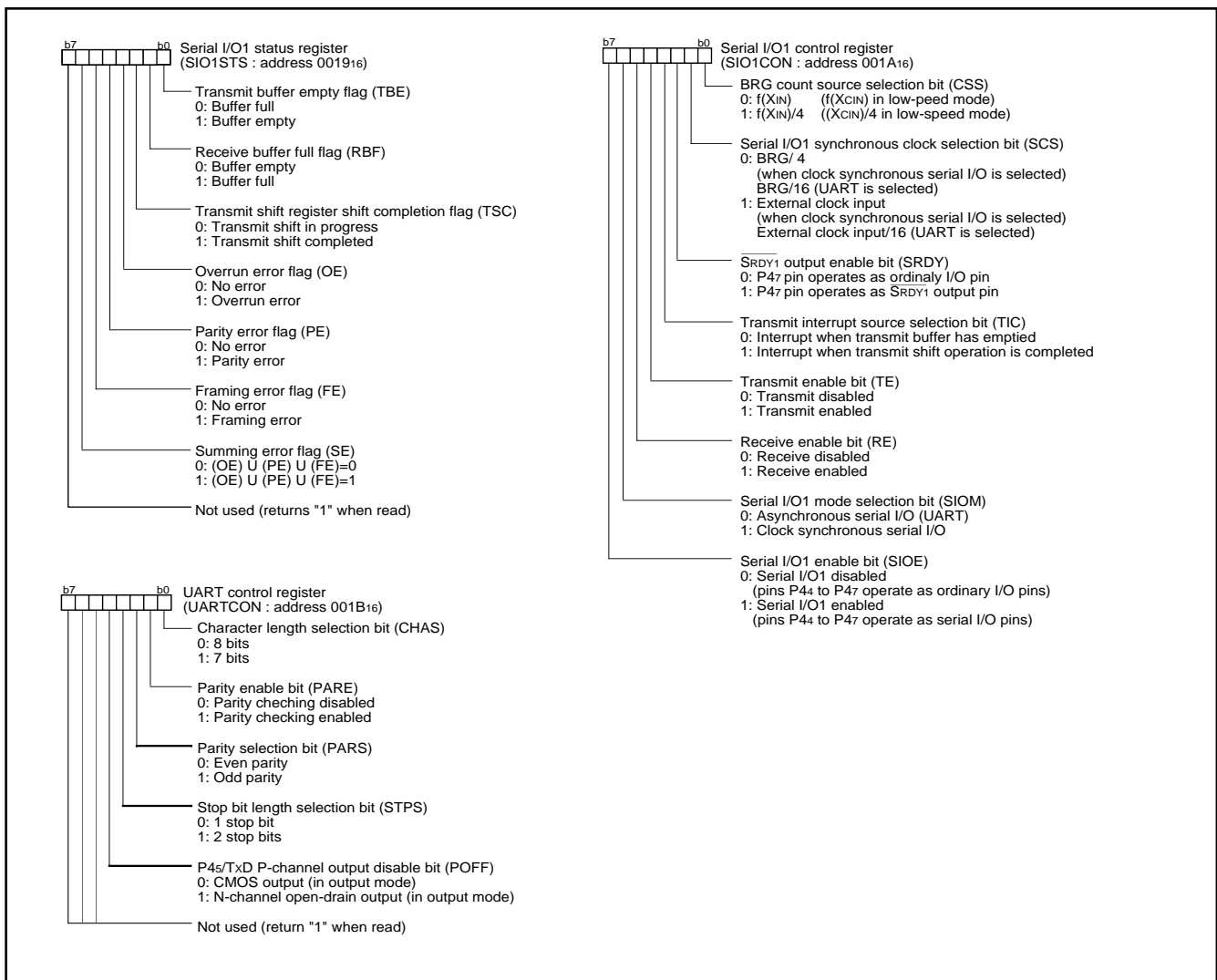

Fig. 37. Structure of serial I/O1 related register

●Serial I/O2

The serial I/O2 can be operated only as the clock synchronous type. As a synchronous clock for serial transfer, either internal clock or external clock can be selected by the serial I/O2 synchronous clock selection bit (b6) of serial I/O2 control register 1.

The internal clock incorporates a dedicated divider and permits selecting 6 types of clock by the internal synchronous clock selection bit (b2, b1, b0) of serial I/O2 control register 1.

Regarding SOUT2 and SCLK2 being output pins, either CMOS output format or N-channel open-drain output format can be selected by the P71/SOUT2, P72/SCLK2 P-channel output disable bit (b7) of serial I/O2 control register 1.

When the internal clock has been selected, a transfer starts by a write signal to the serial I/O2 register (address 001F16). After completion of data transfer, the level of the SOUT2 pin goes to high impedance automatically but bit 7 of the serial I/O2 control register 2 is not set to "1" automatically.

When the external clock has been selected, the contents of the serial I/O2 register is continuously sifted while transfer clocks are input. Accordingly, control the clock externally. Note that the SOUT2 pin does not go to high impedance after completion of data transfer.

To cause the SOUT2 pin to go to high impedance in the case where the external clock is selected, set bit 7 of the serial I/O2 control register 2 to "1" when SCLK2 is "H" after completion of data transfer. After the next data transfer is started (the transfer clock falls), bit 7 of the serial I/O2 control register 2 is set to "0" and the SOUT2 pin is put into the active state.

Regardless of the internal clock to external clock, the interrupt request bit is set after the number of bits (1 to 8 bits) selected by the optional transfer bit is transferred. In case of a fractional number of bits less than 8 bits as the last data, the received data to be stored in the serial I/O2 register becomes a fractional number of bits close to MSB if the transfer direction selection bit of serial I/O2 control register 1 is LSB first, or a fractional number of bits close to LSB if the said bit is MSB first. For the remaining bits, the previously received data is shifted.

At transmit operation using the clock synchronous serial I/O, the SCMP2 signal can be output by comparing the state of the transmit pin SOUT2 with the state of the receive pin SIN2 in synchronization with a rise of the transfer clock. If the output level of the SOUT2 pin is equal to the input level to the SIN2 pin, "L" is output from the SCMP2 pin. If not, "H" is output. At this time, an INT2 interrupt request can also be generated. Select a valid edge by bit 2 of the interrupt edge selection register (address 003A16).

[Serial I/O2 Control Registers 1, 2] SIO2CON1 / SIO2CON2

The serial I/O2 control registers 1 and 2 are containing various selection bits for serial I/O2 control as shown in Figure 40.

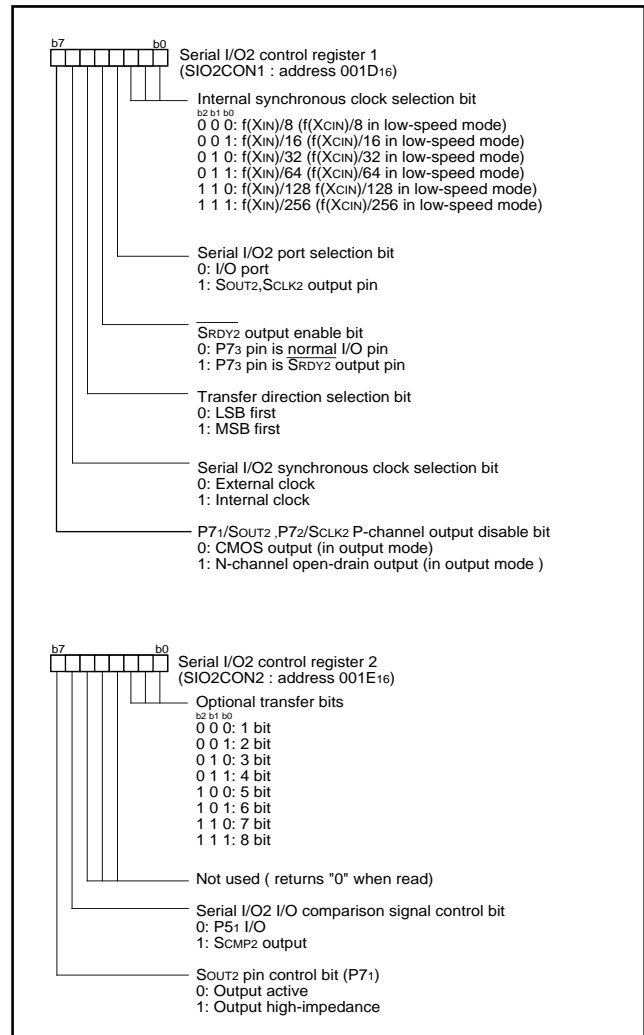

Fig. 38 Structure of Serial I/O2 control registers 1, 2

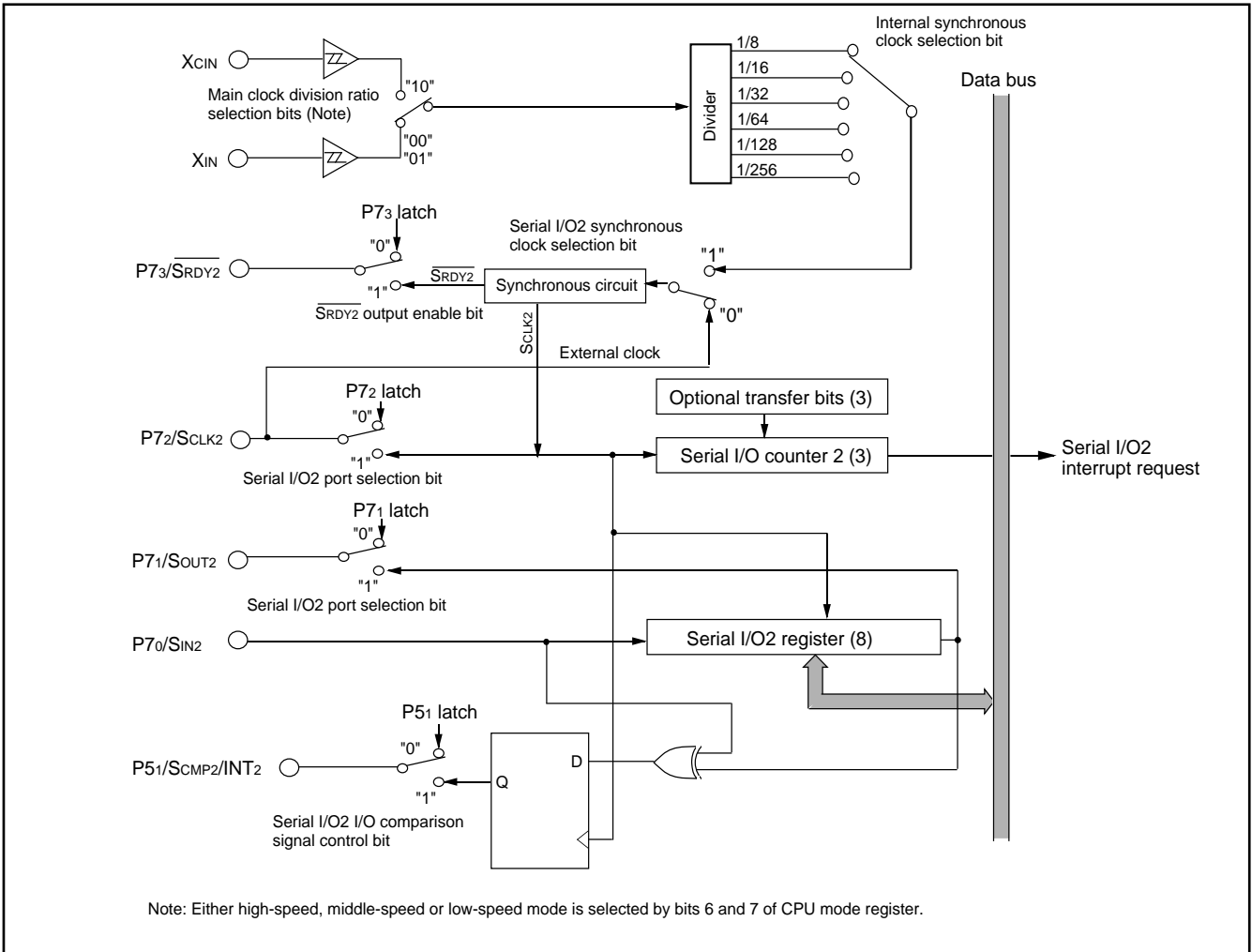

Fig. 39. Block diagram of Serial I/O2

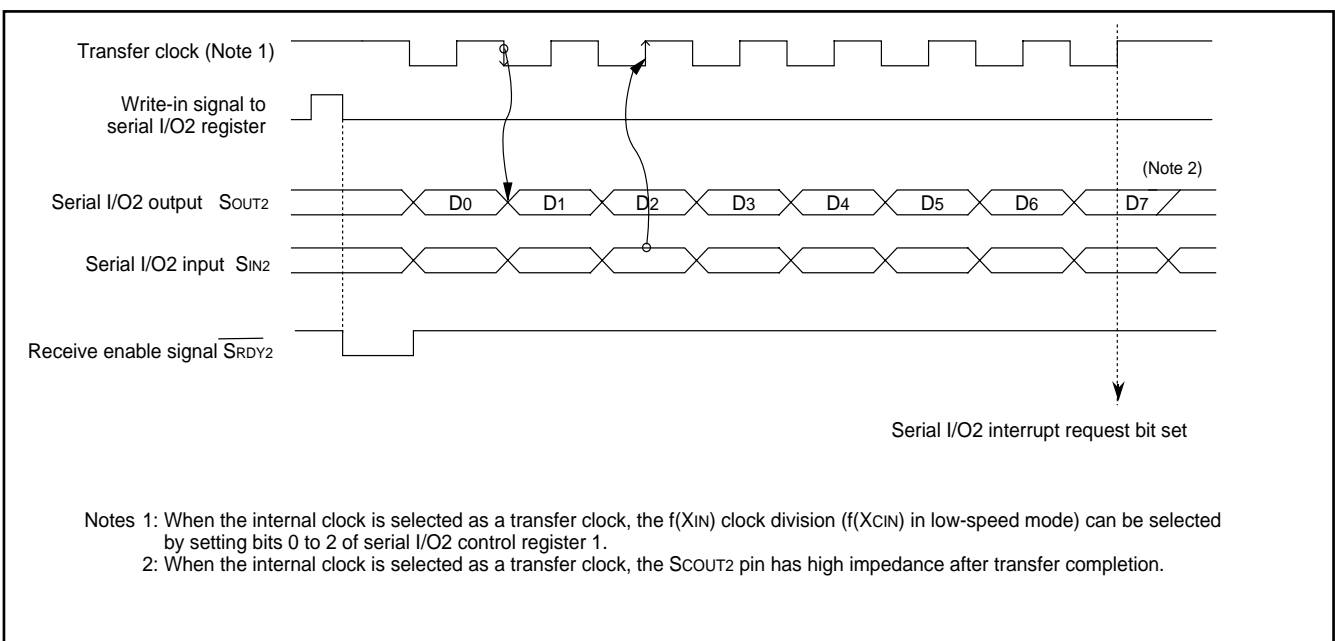

Fig. 40. Timing chart of Serial I/O2

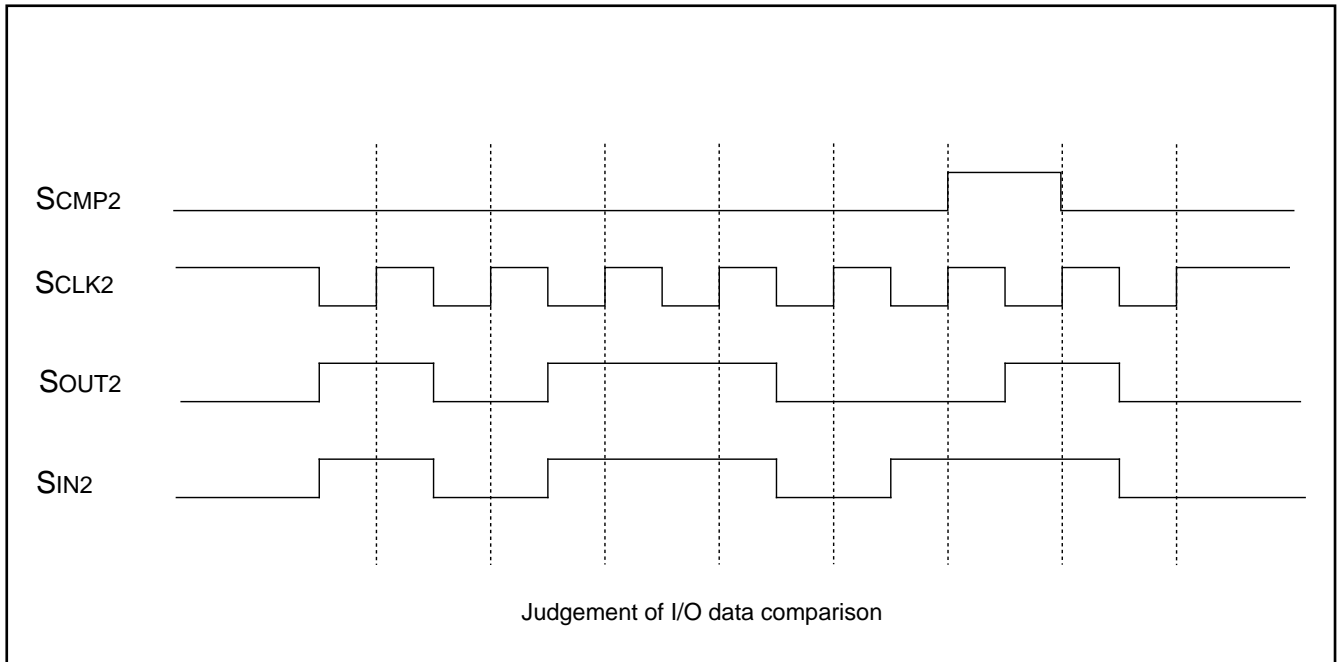

Fig. 41 SCMP2 output operation

A-D Converter

[A-D Conversion Register] AD (address 0035₁₆)

The A-D conversion register is a read-only register that contains the result of an A-D conversion. When reading this register during an A-D conversion, the previous conversion result is read.

[A-D Control Register] ADCON

The A-D control register controls the A-D conversion process. Bits 0 to 3 of this register select specific analog input pins. Bit 4 signals the completion of an A-D conversion. The value of this bit remains at "0" during an A-D conversion, then changes to "1" when the A-D conversion is completed. Writing "0" to this bit starts the A-D conversion. When bit 6, which is the AD external trigger valid bit, is set to "1", this bit enables A-D conversion at a falling edge of an ADT input. Set ports which is also used as ADT pins to input when using an A-D external trigger. Bit 5 is the ADVREF input switch bit. Writing "1" to this bit, this bit always causes ADVREF connection. Writing "0" to this bit causes ADVREF connection only during A-D conversion and cut off when A-D conversion is completed.

[Comparison Voltage Generator]

The comparison voltage generator divides the voltage between AV_{SS} and ADVREF by 256, and outputs the divided voltages.

[Channel Selector]

The channel selector selects one of the input ports AN₁₂ to AN₀ and inputs it to the comparator.

[Comparator and Control Circuit]

The comparator and control circuit compares an analog input voltage with the comparison voltage and stores the result in the A-D conversion register. When an A-D conversion is completed, the control circuit sets the AD conversion completion bit and the AD conversion interrupt request bit to "1."

Note that the comparator is constructed linked to a capacitor, so set

f(X_{IN}) to at least 500kHz during A-D conversion. Use a CPU system clock dividing the main clock X_{IN} as the internal clock ϕ .

■Note

When the A-D external trigger is invalidated by the AD external trigger valid bit, any interrupt request is not generated at a fall of the ADT input. When the AD external trigger valid bit is set to "1" beforehand, A-D conversion is not started by writing "0" into the AD conversion completion bit and "0" is not written into the AD conversion completion bit. Do not set "0" in the AD conversion completion bit concurrently with the timing at which the AD external trigger valid bit is rewritten. Put an interval of at least 50 cycles to more of the internal clock ϕ between a start of A-D conversion and the next start of A-D conversion.

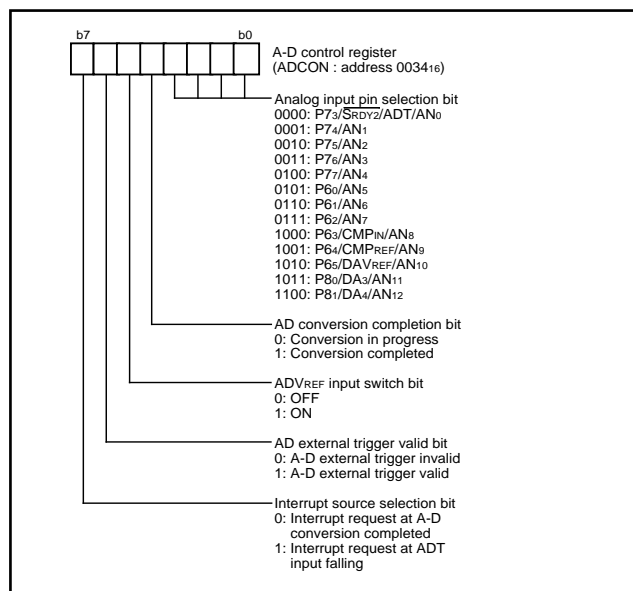

Fig. 42. Structure of A-D control register

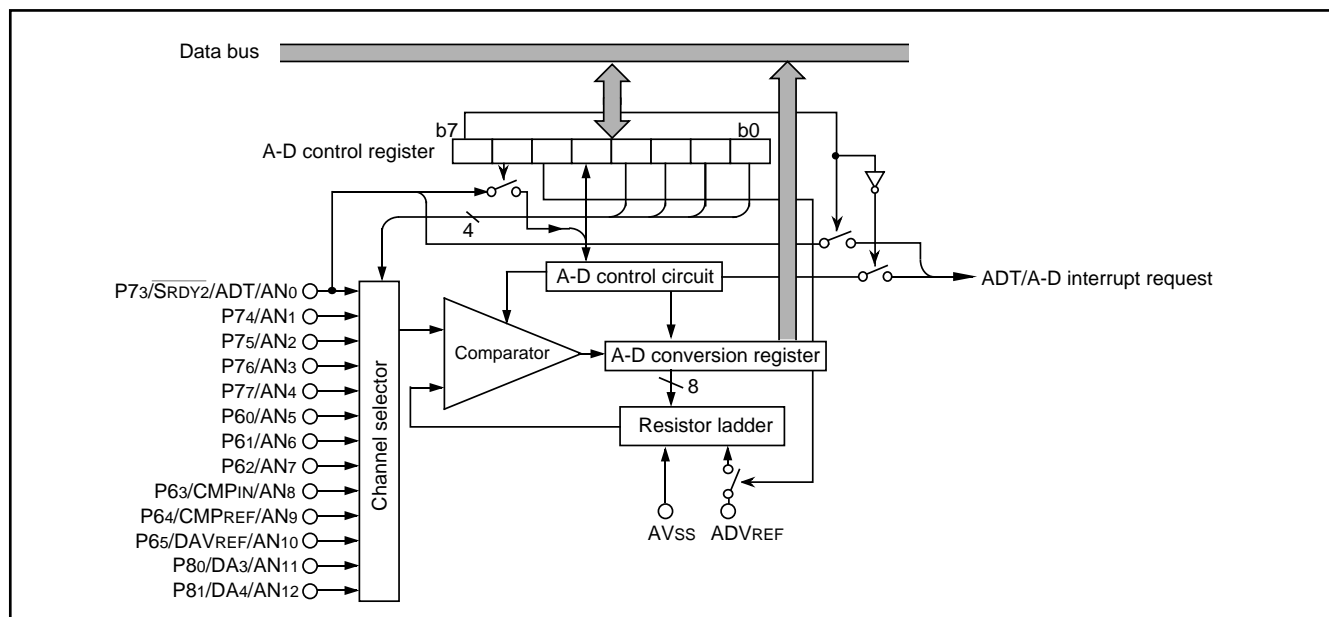

Fig. 43. Block diagram of A-D converter

D-A Converter

The 3807 group has an on-chip D-A converter with 8-bit resolution and 4 channels (DA_i (i=1—4)). The D-A converter is performed by setting the value in the D-A conversion register. The result of D-A converter is output from DA_i pin by setting the DA_i output enable bits to "1." When using the D-A converter, the corresponding port direction register bit (P6₅/DAVREF/AN10, P5₆/DA1, P5₇/DA2, P8₀/DA3/AN11, P8₁/DA4/AN12) should be set to "0" (input status). The output analog voltage V is determined by the value n (base 10) in the D-A conversion register as follows:

$$V = DAV_{REF} \times n / 256 \quad (n=0 \text{ to } 255)$$

Where DAV_{REF} is the reference voltage.

At reset, the D-A conversion registers are cleared to "0016", the DA_i output enable bits are cleared to "0", and DA_i pin is set to input (high impedance). The DA output is not buffered, so connect an external buffer when driving a low-impedance load.

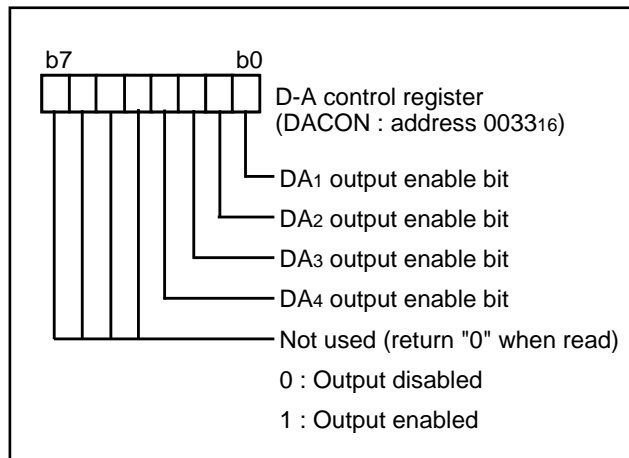

Fig. 44. Structure of D-A control register

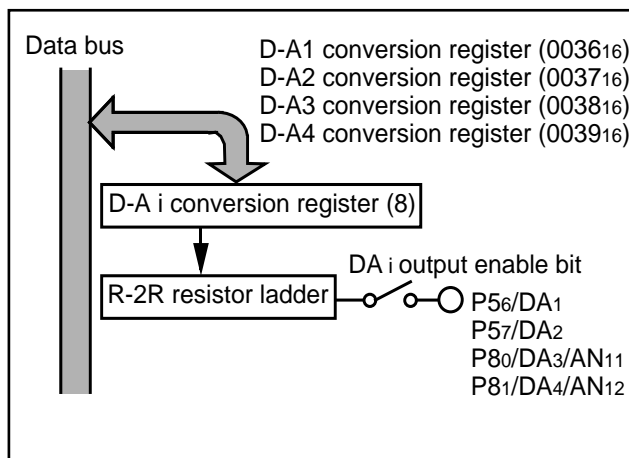

Fig. 45. Block diagram of D-A converter

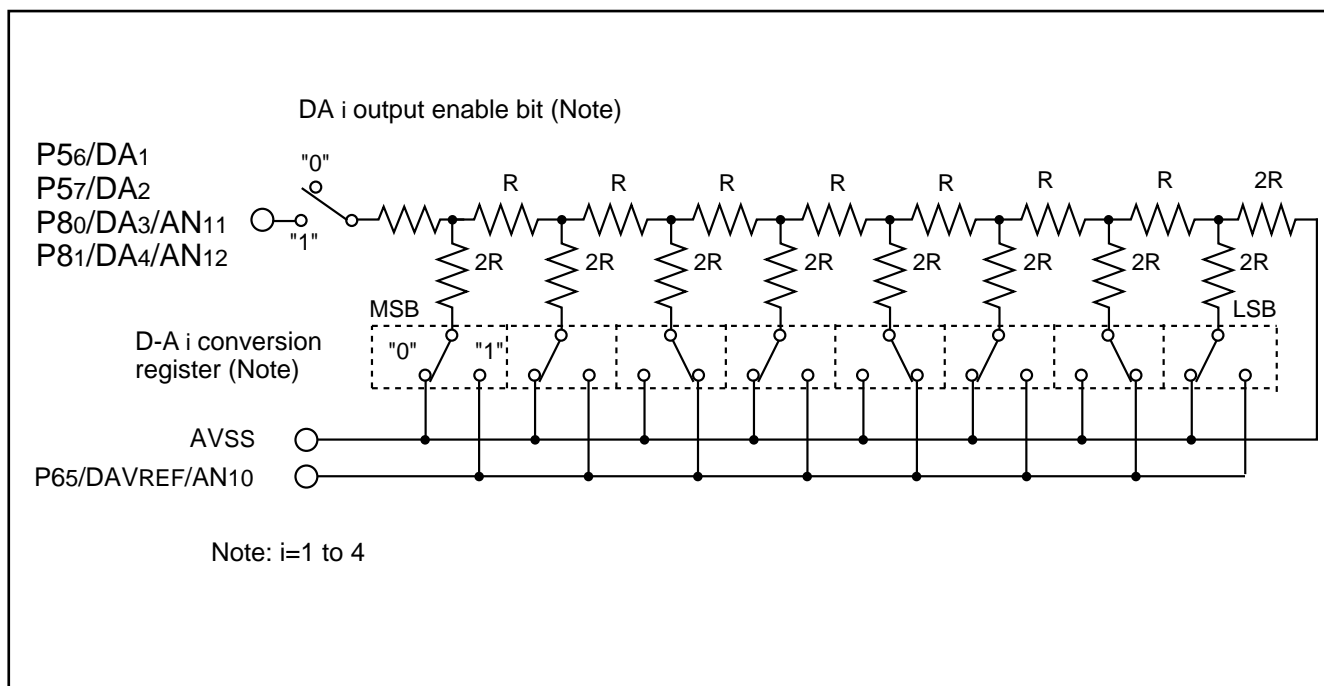

Fig. 46. Equivalent connection circuit of D-A converter

Analog Comparator

An analog comparator circuit which is independent of peripheral circuits in the microcomputer is incorporated (**Note**).

An analog comparator outputs the result of comparison with an input voltage of CMPREF pin which is specified as a reference voltage and an input voltage of CMPIN pin to CMPOUT pin. The result is "1" when the input voltage to port CMPIN is higher than the voltage applied to port CMPREF and "0" when the voltage is lower.

Because the analog comparator consists of an analog MOS circuit, set the input voltage to the CMPIN pin and the CMPREF pin within the following range :

$$V_{ss} + 1.2 \text{ V to } CMPV_{CC} - 0.5 \text{ V}$$

■**Note**

The analog comparator circuit is separated from the MCU internal peripheral circuit in the microcomputer. Accordingly, even if the microcomputer runs away, the analog comparator is still in operation. For this reason, the analog comparator can be used for safety circuit design.

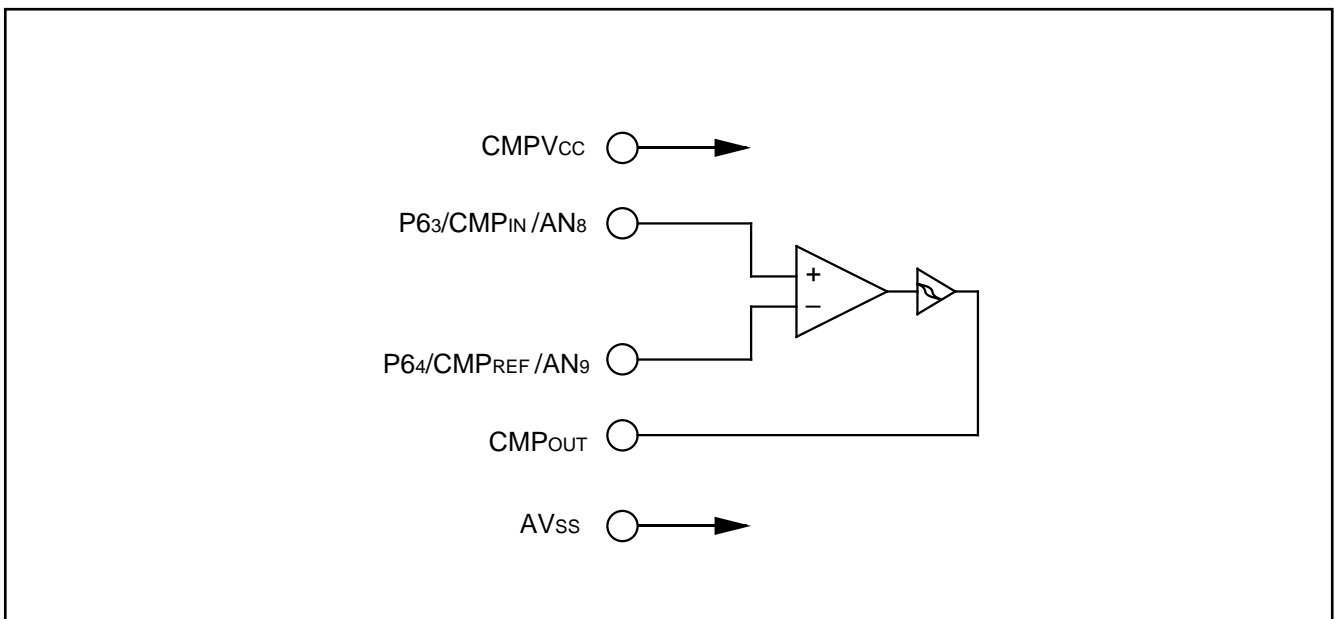

Fig. 47. Block diagram of Analog comparator

Watchdog Timer

The watchdog timer gives a mean of returning to the reset status when a program cannot run on a normal loop (for example, because of a software run-away). The watchdog timer consists of an 8-bit watchdog timer L and a 8-bit watchdog timer H.

Standard operation of watchdog timer

When any data is not written into the watchdog timer control register (address 0017₁₆) after resetting, the watchdog timer is in the stop state. The watchdog timer starts to count down by writing an optional value into the watchdog timer control register (address 0017₁₆) and an internal resetting takes place at an underflow of the watchdog timer H.

Accordingly, programming is usually performed so that writing to the watchdog timer control register (address 0017₁₆) may be started before an underflow. When the watchdog timer control register (address 0017₁₆) is read, the values of the 6 high-order bits of the watchdog timer H, STP instruction disable bit, and watchdog timer H count source selection bit are read.

(1) Initial value of watchdog timer

At reset or writing to the watchdog timer control register (address 0017₁₆), each watchdog timer H and L is set to "FF₁₆."

(2) Watchdog timer H count source selection bit operation

Bit 7 of the watchdog timer control register (address 0017₁₆) permits selecting a watchdog timer H count source. When this bit is set to "0", the count source becomes the underflow signal of watchdog timer L. The detection time is set then to $f(X_{IN})=131.072$ ms at 8 MHz frequency and $f(X_{CIN})=32.768$ s at 32 kHz frequency.

When this bit is set to "1", the count source becomes the signal divided by 16 for $f(X_{IN})$ (or $f(X_{CIN})$). The detection time in this case is set to $f(X_{IN})=512$ μ s at 8 MHz frequency and $f(X_{CIN})=128$ ms at 32 KHz frequency. This bit is cleared to "0" after resetting.

(3) Operation of STP instruction disable bit

Bit 6 of the watchdog timer control register (address 0017₁₆) permits disabling the STP instruction when the watchdog timer is in operation.

When this bit is "0", the STP instruction is enabled.

When this bit is "1", the STP instruction is disabled.

Once the STP instruction is executed, an internal resetting takes place.

When this bit is set to "1", it cannot be rewritten to "0" by program. This bit is cleared to "0" after resetting.

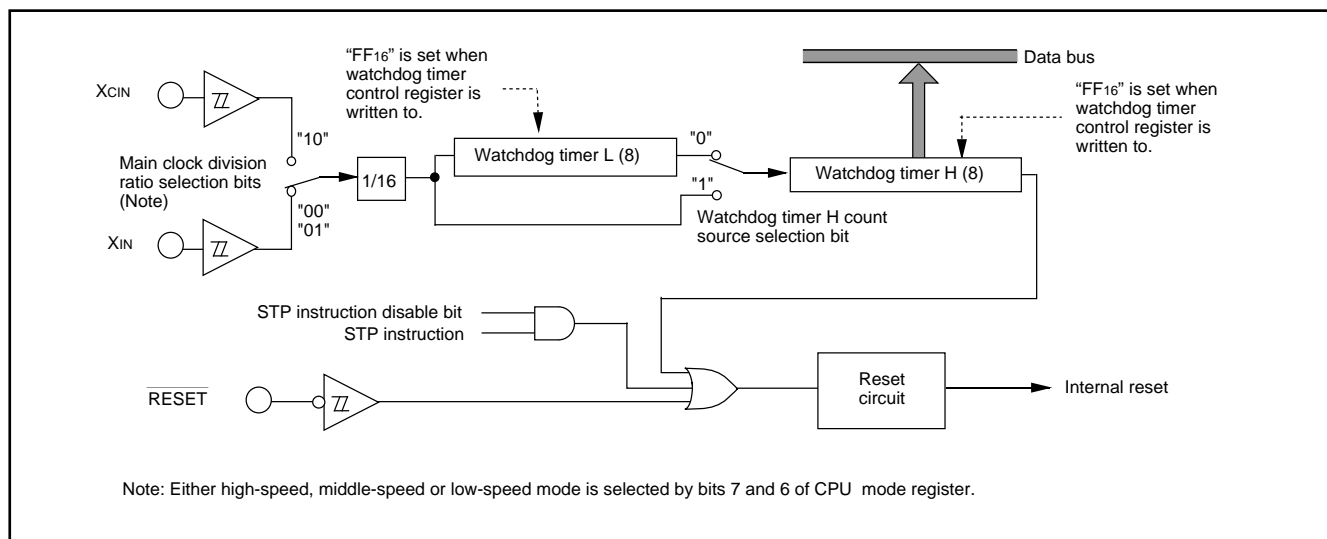

Fig. 48. Block diagram of Watchdog timer

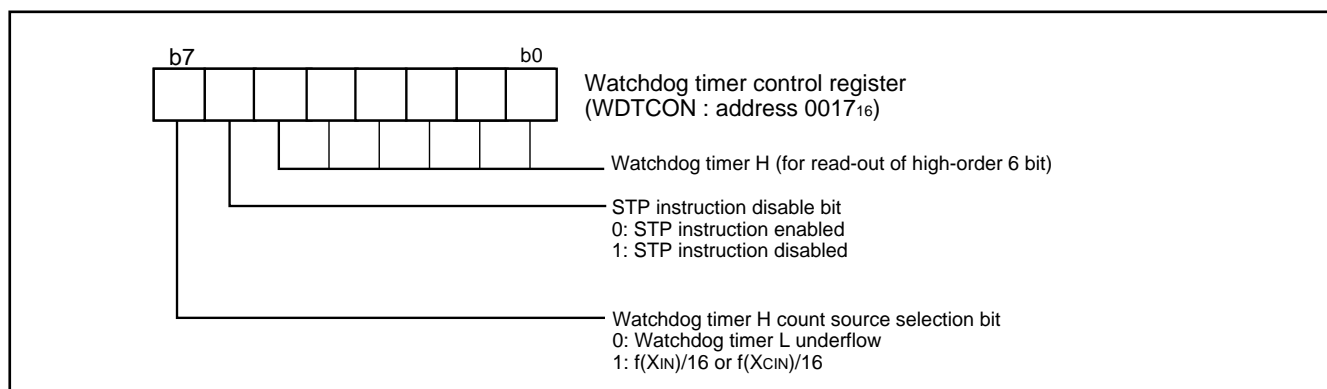

Fig. 49. Structure of Watchdog timer control register

Clock output function

The internal clock ϕ can be output from I/O port P34. Control of I/O ports and clock output function can be performed by port P2P3 control register (address 0015₁₆).

(1) I/O ports or clock output function selection

The P34 clock output control bit (b0) of port P2P3 control register selects the I/O port or clock output function. When clock output function is selected, the clock is output regardless of the port P34 direction register settings.

Directly after bit 0 is written to, the port or clock output is switched synchronous to a falling edge of clock frequency selected by the output clock frequency selection bit. When memory expansion mode or microprocessor mode is selected in CPU mode register (b1, b0), clock output is selected on regardless of P34 clock output control bit settings or port P34 direction register settings.

(2) Selection of output clock frequency

The output clock frequency selection bits (b3, b2, b1) of port P2P3 control register select the output clock frequency.

The output waveform when $f(X_{IN})$ or $f(X_{CIN})$ is selected, depends on X_{IN} or X_{CIN} input waveform however; all other output waveform settings have a duty cycle of 50%.

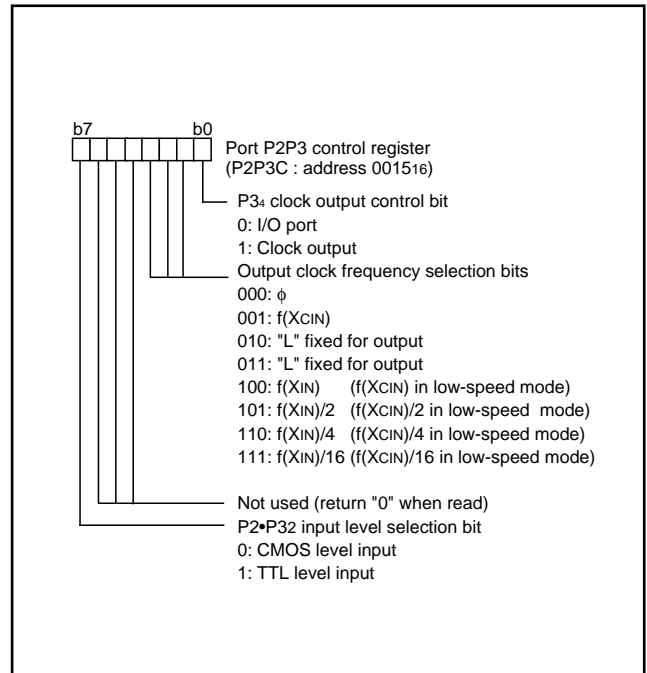
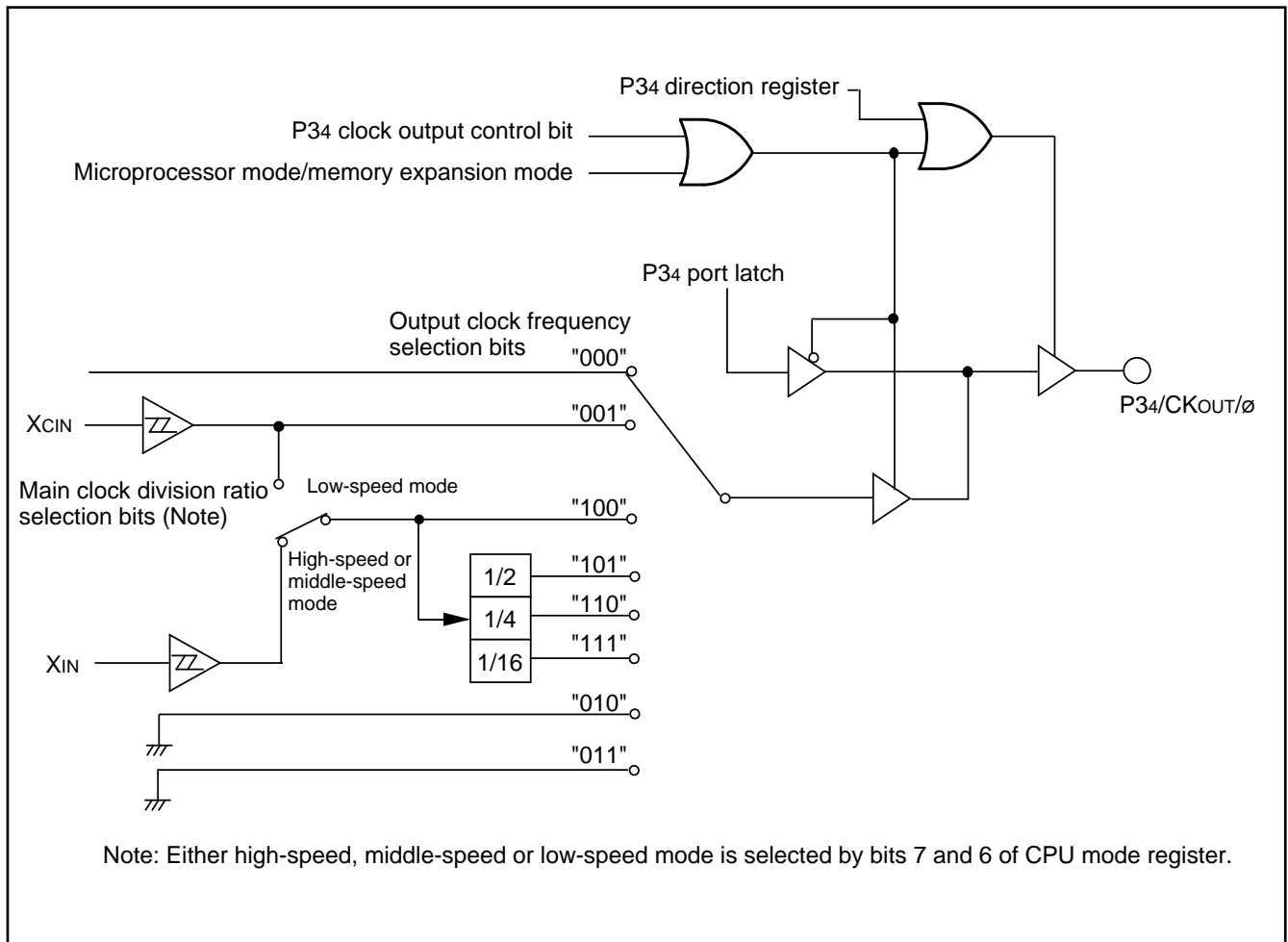

Fig. 50. Structure of Port P2P3 control register



Note: Either high-speed, middle-speed or low-speed mode is selected by bits 7 and 6 of CPU mode register.

Fig. 51. Block diagram of Clock output function

Reset Circuit

To reset the microcomputer, RESET pin should be held at an "L" level for 2 μ s or more. Then the RESET pin is returned to an "H" level (the power source voltage should be between 2.7 V and 5.5 V, and the oscillation should be stable), reset is released. After the reset is completed, the program starts from the address contained in address FFFD₁₆ (high-order byte) and address FFFC₁₆ (low-order byte). Make sure that the reset input voltage is less than 0.54 V for V_{cc} of 2.7 V.

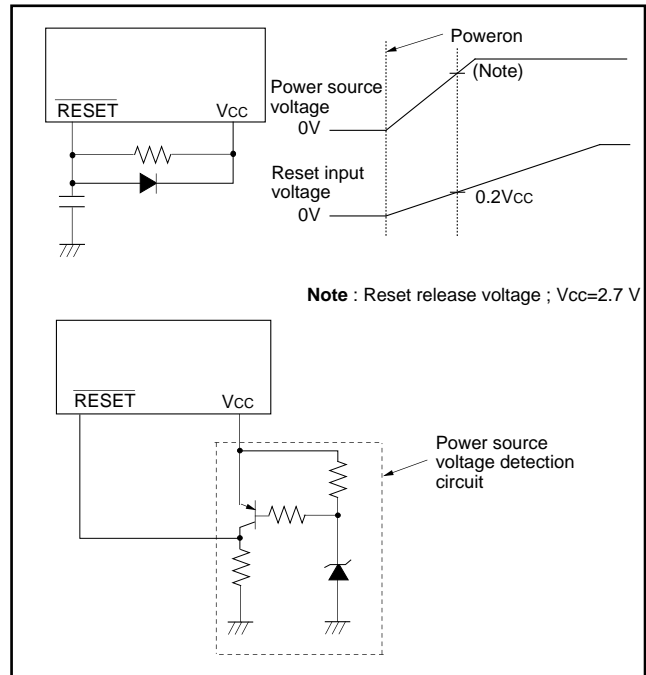

Fig. 52. Reset circuit example

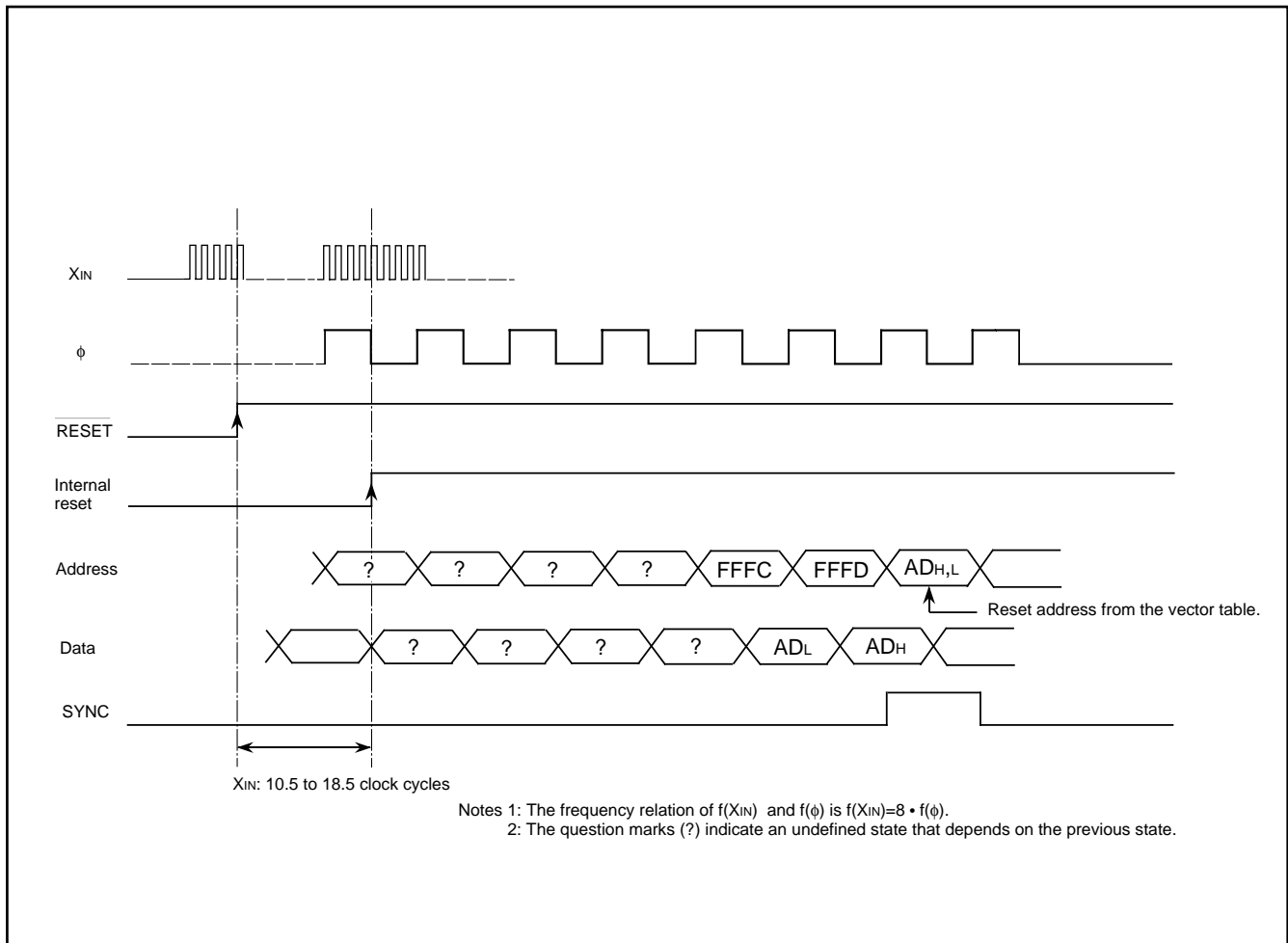

Fig. 53. Reset sequence

	Address	Register contents		Address	Register contents
(1) Port P0	0000 ₁₆	00 ₁₆	(34) Timer 3	0026 ₁₆	FF ₁₆
(2) Port P0 direction register	0001 ₁₆	00 ₁₆	(35) Timer X mode register	0027 ₁₆	00 ₁₆
(3) Port P1	0002 ₁₆	00 ₁₆	(36) Timer Y mode register	0028 ₁₆	00 ₁₆
(4) Port P1 direction register	0003 ₁₆	00 ₁₆	(37) Timer 123 mode register	0029 ₁₆	00 ₁₆
(5) Port P2	0004 ₁₆	00 ₁₆	(38) Real time port register 0—7	002A ₁₆	00 ₁₆
(6) Port P2 direction register	0005 ₁₆	00 ₁₆	(39) Real time port control register 0	002B ₁₆	10010000
(7) Port P3	0006 ₁₆	00 ₁₆	(40) Real time port control register 1	002C ₁₆	1---0000
(8) Port P3 direction register	0007 ₁₆	00 ₁₆	R/W pointer		-111----
(9) Port P4	0008 ₁₆	00 ₁₆	Output pointer		-111----
(10) Port P4 direction register	0009 ₁₆	00 ₁₆	(41) Real time port control register 2	002D ₁₆	1---0000
(11) Port P5	000A ₁₆	00 ₁₆	R/W pointer		-111----
(12) Port P5 direction register	000B ₁₆	00 ₁₆	Output pointer		-111----
(13) Port P6	000C ₁₆	00 ₁₆	(42) Real time port control register 3	002E ₁₆	00 ₁₆
(14) Port P6 direction register	000D ₁₆	00 ₁₆	(43) Timer A (low-order)	002F ₁₆	FF ₁₆
(15) Port P7	000E ₁₆	00 ₁₆	(44) Timer A (high-order)	0030 ₁₆	FF ₁₆
(16) Port P7 direction register	000F ₁₆	00 ₁₆	(45) Timer B (low-order)	0031 ₁₆	FF ₁₆
(17) Port P8	0010 ₁₆	00 ₁₆	(46) Timer B (high-order)	0032 ₁₆	FF ₁₆
(18) Port P8 direction register	0011 ₁₆	00 ₁₆	(47) D-A control register	0033 ₁₆	00 ₁₆
(19) Timer XY control register	0014 ₁₆	0000011	(48) A-D control register	0034 ₁₆	00010000
(20) Port P2P3 control register	0015 ₁₆	*0000000	(49) D-A1 conversion register	0036 ₁₆	00 ₁₆
(21) Pull-up control register	0016 ₁₆	00 ₁₆	(50) D-A2 conversion register	0037 ₁₆	00 ₁₆
(22) Watchdog timer control register	0017 ₁₆	0011111	(51) D-A3 conversion register	0038 ₁₆	00 ₁₆
(23) Serial I/O1 status register	0019 ₁₆	10000000	(52) D-A4 conversion register	0039 ₁₆	00 ₁₆
(24) Serial I/O1 control register	001A ₁₆	00 ₁₆	(53) Interrupt edge selection register	003A ₁₆	00 ₁₆
(25) UART control register	001B ₁₆	11100000	(54) CPU mode register	003B ₁₆	010010*0
(26) Serial I/O2 control register 1	001D ₁₆	00 ₁₆	(55) Interrupt request register 1	003C ₁₆	00 ₁₆
(27) Serial I/O2 control register 2	001E ₁₆	0000011	(56) Interrupt request register 2	003D ₁₆	00 ₁₆
(28) Timer X (low-order)	0020 ₁₆	FF ₁₆	(57) Interrupt control register 1	003E ₁₆	00 ₁₆
(29) Timer X (high-order)	0021 ₁₆	FF ₁₆	(58) Interrupt control register 2	003F ₁₆	00 ₁₆
(30) Timer Y (low-order)	0022 ₁₆	FF ₁₆	(59) Processor status register	(PS)	XXXX1XX
(31) Timer Y (high-order)	0023 ₁₆	FF ₁₆	(60) Program counter	(PC _H)	FFFD ₁₆ contents
(32) Timer 1	0024 ₁₆	FF ₁₆		(PC _L)	FFFC ₁₆ contents
(33) Timer 2	0025 ₁₆	01 ₁₆			

* The initial values depend on level of port CNV_{ss}.
X: Not fixed
Since the initial values for other than above mentioned registers and RAM contents are indefinite at reset, they must be set.

Fig. 54. Internal status at reset

Clock Generating Circuit

The 3807 group has two built-in oscillation circuits. An oscillation circuit can be formed by connecting a resonator between X_{IN} and X_{OUT} (X_{CIN} and X_{COUT}). Use the circuit constants in accordance with the resonator manufacturer's recommended values. No external resistor is needed between X_{IN} and X_{OUT} since a feed-back resistor exists on-chip. However, an external feed-back resistor is needed between X_{CIN} and X_{COUT} .

Immediately after poweron, only the X_{IN} oscillation circuit starts oscillating, and X_{CIN} and X_{COUT} pins function as I/O ports.

●Frequency control

(1) Middle-speed mode

The internal clock ϕ is the frequency of X_{IN} divided by 8. After reset, this mode is selected.

(2) High-speed mode

The internal clock ϕ is half the frequency of X_{IN} .

(3) Low-speed mode

The internal clock ϕ is half the frequency of X_{CIN} .

■Note

If you switch the mode between middle/high-speed and low-speed, stabilize both X_{IN} and X_{CIN} oscillations. The sufficient time is required for the sub clock to stabilize, especially immediately after poweron and at returning from stop mode. When switching the mode between middle/high-speed and low-speed, set the frequency on condition that $f(X_{IN}) > 3f(X_{CIN})$.

(4) Low power consumption mode

The low power consumption operation can be realized by stopping the main clock X_{IN} in low-speed mode. To stop the main clock, set bit 5 of the CPU mode register to "1." When the main clock X_{IN} is re-started (by setting the main clock stop bit to "0"), set enough time for oscillation to stabilize.

By clearing furthermore the X_{COUT} drivability selection bit (b3) of CPU mode register to "0", low power consumption operation of less than $55 \mu A$ ($V_{CC}=3 V$, $X_{CIN}=32 \text{ kHz}$) can be realized by reducing the drivability between X_{CIN} and X_{COUT} . At reset or during STP instruction execution this bit is set to "1" and a reduced drivability that has an easy oscillation start is set. The sub-clock X_{CIN} - X_{COUT} oscillating circuit can not directly input clocks that are generated externally. Accordingly, make sure to cause an external resonator to oscillate.

●Oscillation control

(1) Stop mode

If the STP instruction is executed, the internal clock ϕ stops at an "H" level, and X_{IN} and X_{CIN} oscillators stop. Timer 1 is set to "FF₁₆" and timer 2 is set to "01₁₆."

Either X_{IN} or X_{CIN} divided by 16 is input to timer 1 as count source, and the output of timer 1 is connected to timer 2. The bits of the timer 123 mode register except timer 3 count source selection bit (b4) are cleared to "0". Set the timer 2/INT₃ interrupt source bit to "1" and timer 1/INT₂ as well as timer 2/INT₃ interrupt enable bit to disabled

("0") before executing the STP instruction. Oscillator restarts when an external interrupt is received, but the internal clock ϕ is not supplied to the CPU (remains at "H") until timer 2 underflows. This allows time for the clock circuit oscillation to stabilize. The internal clock ϕ is supplied for the first time, when timer 2 underflows. Therefore make sure not to set the timer 2/INT₃ interrupt request bit to "1" before the STP instruction stops the oscillator. When the oscillator is restarted by reset apply "L" level to port $\overline{\text{RESET}}$ until the oscillation is stable since a wait time will not be generated.

(2) Wait mode

If the WIT instruction is executed, the internal clock ϕ stops at an "H" level. The states of X_{IN} and X_{CIN} are the same as the state before executing the WIT instruction. The internal clock restarts at reset or when an interrupt is received. Since the oscillator does not stop, normal operation can be started immediately after the clock is restarted.

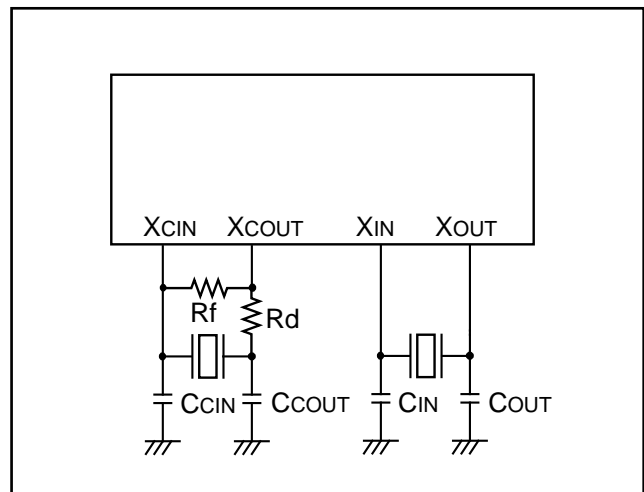

Fig. 55. Ceramic resonator circuit

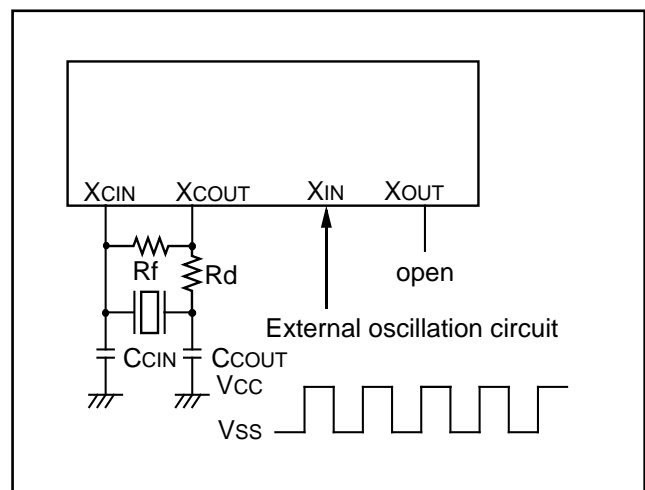

Fig. 56. External clock input circuit

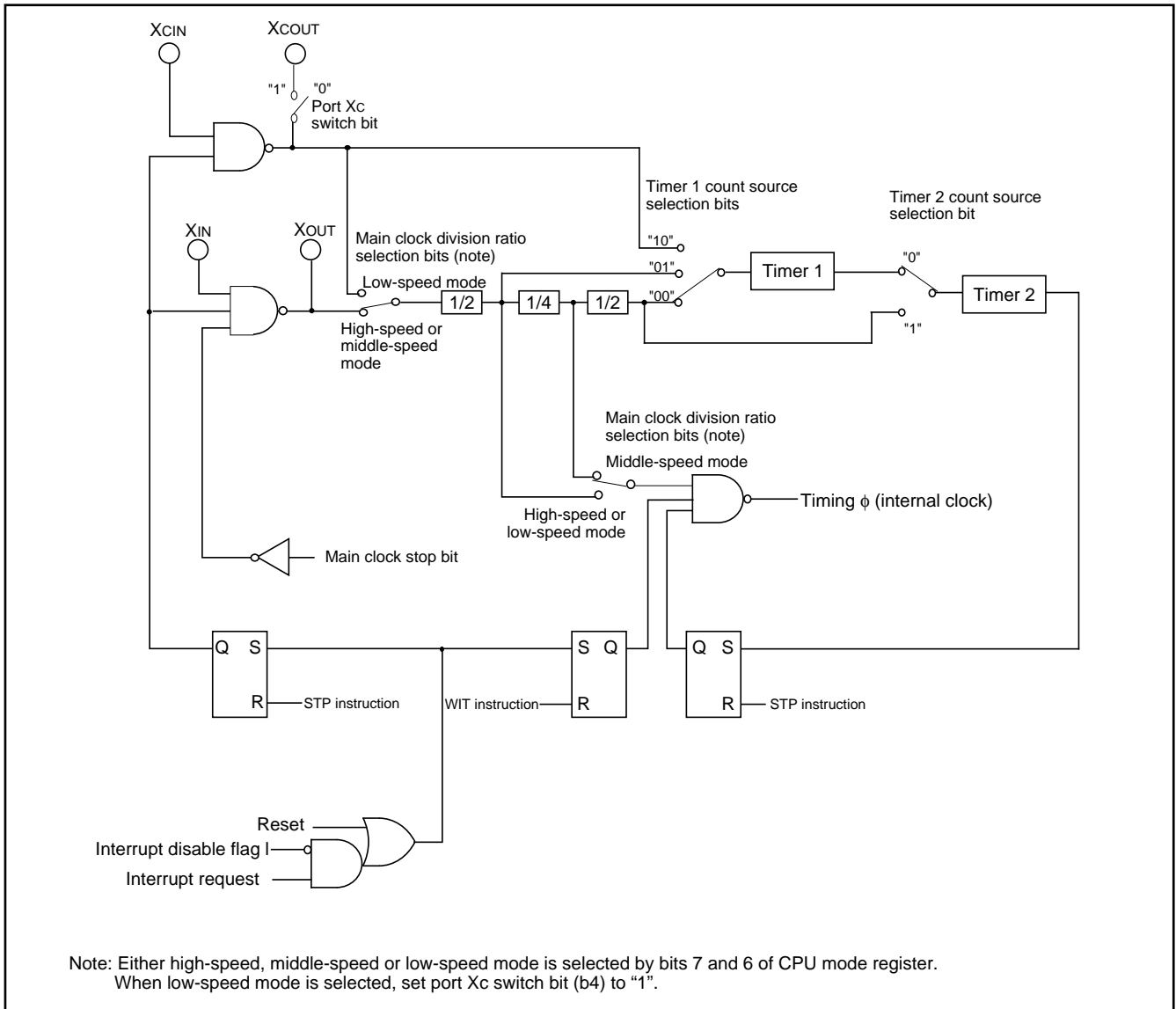

Fig. 57. System clock generating circuit block diagram (Single-chip mode)

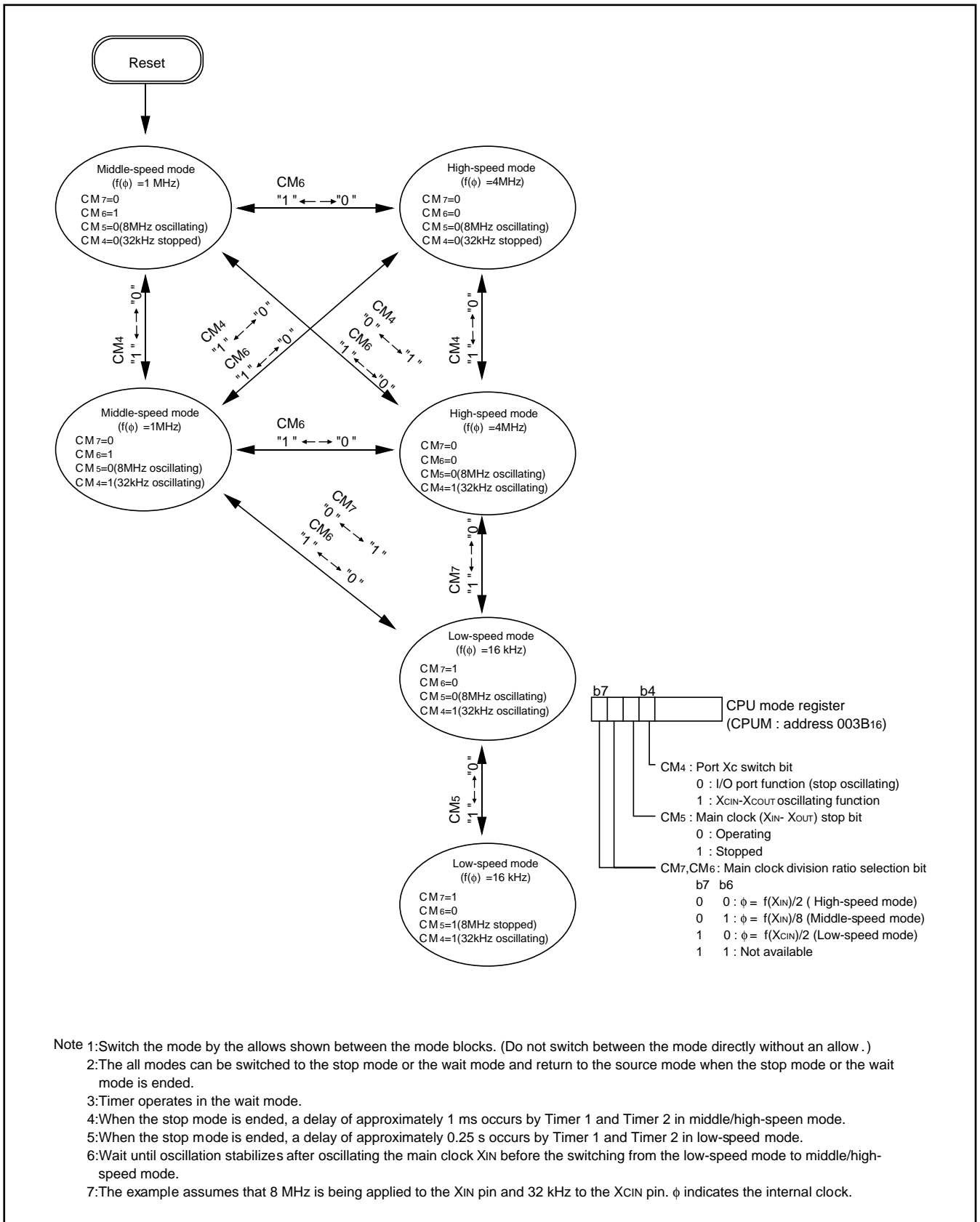

Fig. 58. State transitions of system clock

Processor Mode

Single-chip mode, memory expansion mode, and microprocessor mode can be selected by changing the contents of the processor mode bits (CM₀ and CM₁ : b1 and b0 of address 003B₁₆). In memory expansion mode and microprocessor mode, memory can be expanded externally through ports P0 to P3. In these modes, ports P0 to P3 lose their I/O port functions and become bus pins.

Table 7. Port functions in memory expansion mode and microprocessor mode

Port Name	Function
Port P0	Outputs 8-bits low-order byte of address.
Port P1	Outputs 8-bits high-order byte of address.
Port P2	Operates as I/O pins for data D ₇ to D ₀ (including instruction code)
Port P3	P ₃₀ and P ₃₁ function only as output pins (except that the port latch cannot be read). P ₃₂ is the \overline{ONW} input pin. P ₃₃ is the $\overline{RESTOUT}$ output pin. (Note) P ₃₄ is the ϕ output pin. P ₃₅ is the \overline{SYNC} output pin. P ₃₆ is the \overline{WR} output pin, and P ₃₇ is the \overline{RD} output pin.

Note : If CNV_{SS} is connected to V_{SS}, the microcomputer goes to single-chip mode after a reset, so this pin cannot be used as the $\overline{RESETOUT}$ output pin.

(1) Single-chip mode

Select this mode by resetting the microcomputer with CNV_{SS} connected to V_{SS}.

(2) Memory expansion mode

Select this mode by setting the processor mode bits (b1, b0) to "01" in software with CNV_{SS} connected to V_{SS}. This mode enables external memory expansion while maintaining the validity of the internal ROM. However, some I/O devices will not support the memory expansion mode. Internal ROM will take precedence over external memory if addresses conflict.

(3) Microprocessor mode

Select this mode by resetting the microcomputer with CNV_{SS} connected to V_{CC}, or by setting the processor mode bits to "10" in software with CNV_{SS} connected to V_{SS}. In microprocessor mode, the internal ROM is no longer valid and external memory must be used.

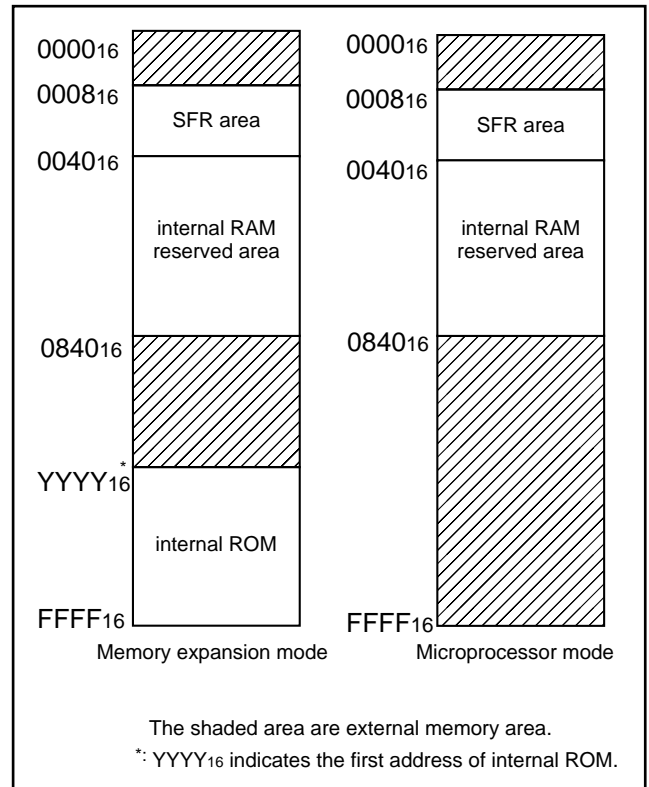

Fig. 59. Memory maps in various processor modes

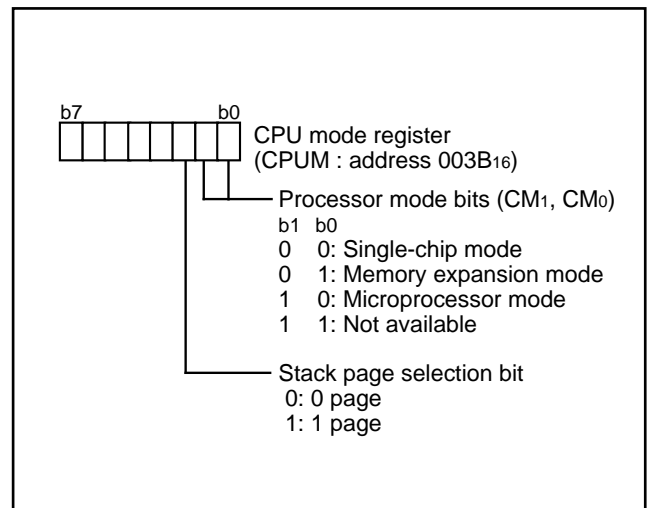

Fig. 60. Structure of CPU mode register

Bus control at memory expansion

The 3807 group has a built-in ONW function to facilitate access to external (expanded) memory and I/O devices in memory expansion mode or microprocessor mode.

If an "L" level signal is input to port P32/ONW when the CPU is in a read or write state, the corresponding read or write cycle is extended by one cycle of ϕ . During this extended period, the RD or WR signal remains at "L". This extension function is valid only for writing to and reading from addresses 0000₁₆ to 0007₁₆ and 0840₁₆ to FFFF₁₆, and only read and write cycles are extended.

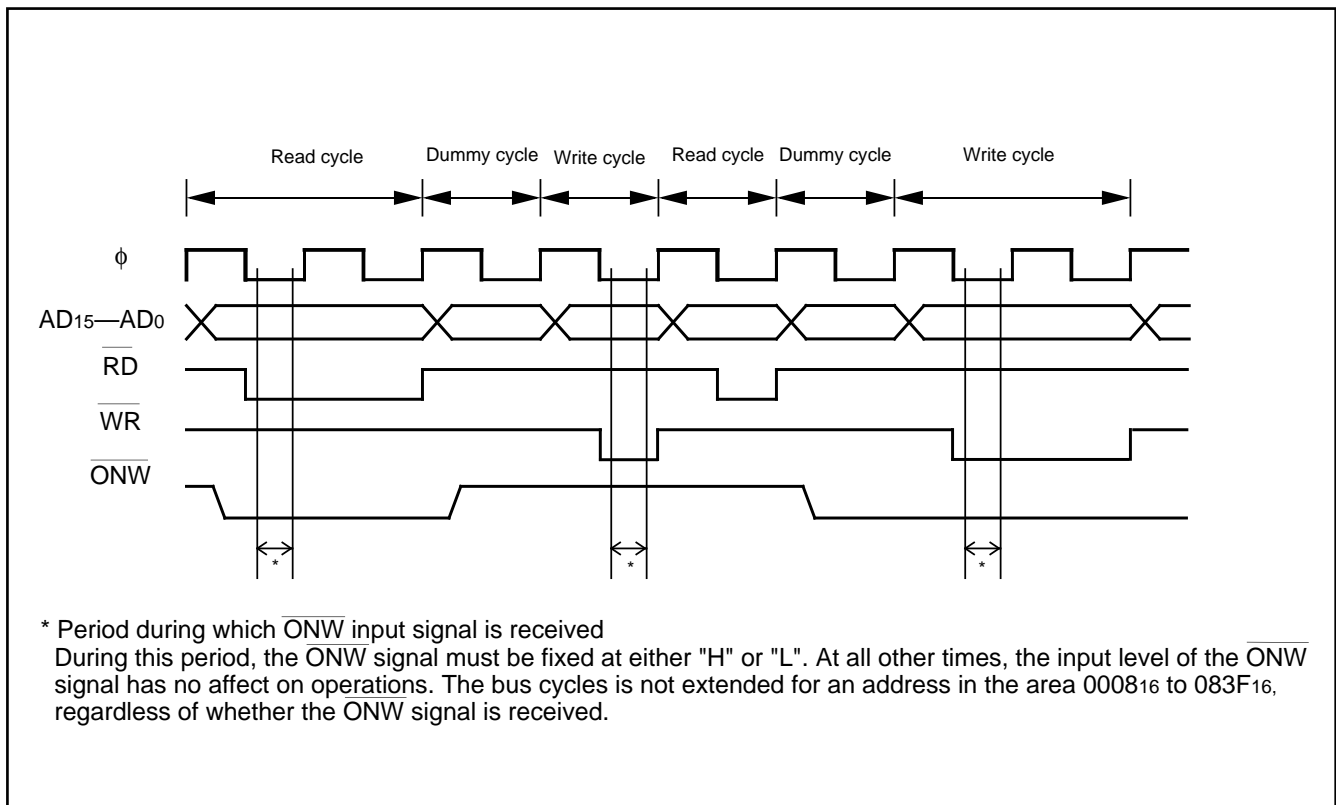

Fig. 61. ONW function timing

NOTES ON PROGRAMMING

Processor Status Register

The contents of the processor status register (PS) after a reset are undefined, except for the interrupt disable flag (I) which is "1." After a reset, initialize flags which affect program execution. In particular, it is essential to initialize the index X mode (T) and the decimal mode (D) flags because of their effect on calculations.

Interrupts

The contents of the interrupt request bits do not change immediately after they have been written. After writing to an interrupt request register, execute at least one instruction before performing a BBC or BBS instruction.

Decimal Calculations

- To calculate in decimal notation, set the decimal mode flag (D) to "1", then execute an ADC or SBC instruction. Only the ADC and SBC instructions yield proper decimal results. After executing an ADC or SBC instruction, execute at least one instruction before executing a SEC, CLC, or CLD instruction.
- In decimal mode, the values of the negative (N), overflow (V), and zero (Z) flags are invalid.

Timers

If a value n (between 0 and 255) is written to a timer latch, the frequency division ratio is $1/(n+1)$.

Multiplication and Division Instructions

- The index X mode (T) and the decimal mode (D) flags do not affect the MUL and DIV instruction.
- The execution of these instructions does not change the contents of the processor status register.

Ports

The contents of the port direction registers cannot be read. The following cannot be used:

- The data transfer instruction (LDA, etc.)
- The operation instruction when the index X mode flag (T) is "1"
- The addressing mode which uses the value of a direction register as an index
- The bit-test instruction (BBC or BBS, etc.) to a direction register
- The read-modify-write instructions (ROR, CLB, or SEB, etc.) to a direction register.

Use instructions such as LDM and STA, etc., to set the port direction registers.

Serial I/O

In clock synchronous serial I/O, if the receive side is using an external clock and it is to output the $SRDY_1$ signal, set the transmit enable bit, the receive enable bit, and the $SRDY_1$ output enable bit to "1."

Serial I/O1 continues to output the final bit from the TxD pin after transmission is completed. $SOUT_2$ pin for serial I/O2 goes to high impedance after transfer is completed.

When in serial I/O1 (clock-synchronous mode) or in serial I/O2 an external clock is used as synchronous clock, write transmission data to both the transmit buffer register and serial I/O2 register, during transfer clock is "H."

A-D Converter

The comparator uses internal capacitors whose charge will be lost if the clock frequency is too low.

Therefore, make sure that $f(X_{IN})$ is at least on 500 kHz during an A-D conversion. (When the ONW pin has been set to "L", the A-D conversion will take twice as long to match the longer bus cycle, and so $f(X_{IN})$ must be at least 1 MHz.)

Do not execute the STP or WIT instruction during an A-D conversion.

D-A Converter

The accuracy of the D-A converter becomes rapidly poor under the $V_{CC} = 4.0$ V or less condition; a supply voltage of $V_{CC} \geq 4.0$ V is recommended. When a D-A converter is not used, set all values of D-Ai conversion registers ($i=1$ to 4) to "0016."

Instruction Execution Time

The instruction execution time is obtained by multiplying the frequency of the internal clock ϕ by the number of cycles needed to execute an instruction.

The number of cycles required to execute an instruction is shown in the list of machine instructions.

The frequency of the internal clock ϕ is half of the X_{IN} frequency in high-speed mode.

When the ONW function is used in modes other than single-chip mode, the frequency of the internal clock ϕ may be one fourth of the X_{IN} frequency.

NOTES ON USAGE

Handling of Source Pins

In order to avoid a latch-up occurrence, connect a capacitor suitable for high frequencies as bypass capacitor between power source pin (Vcc pin) and GND pin (Vss pin) and between power source pin (Vcc pin) and analog power source input pin (AVss pin). Besides, connect the capacitor to as close as possible. For bypass capacitor which should not be located too far from the pins to be connected, a ceramic capacitor of 0.01 μ F—0.1 μ F is recommended.

P34 clock output function

In the case of using an I/O port P34 as a clock output function, note the following : when an output clock frequency is changed during outputting a clock, the port may feed a noise having a shorter pulse width than the standard at the switch timing. Besides, it also may happen at the timing for switching the low-speed mode to the middle/high-speed mode.

Timer X and timer Y

In the pulse period measurement mode or the pulse width measurement mode for timers X and Y, set the "L" or "H" pulse width of input signal from CNTR0/CNTR1 pin to 2 cycles or more of a timer count source.

EPROM version/One Time PROM version

The CNVss pin is connected to the internal memory circuit block by a low-ohmic resistance, since it has the multiplexed function to be a programmable power source pin (VPP pin) as well.

To improve the noise reduction, connect a track between CNVss pin and Vss pin or Vcc pin with 1 to 10 k Ω resistance.

The mask ROM version track of port CNVss has no operational interference even if it is connected via a resistor.

DATA REQUIRED FOR MASK ORDERS

The following are necessary when ordering a mask ROM production:

- (1) Mask ROM Order Confirmation Form
- (2) Mask Specification Form
- (3) Data to be written to ROM, in EPROM form (three identical copies)

ROM PROGRAMMING METHOD

The built-in PROM of the blank One Time PROM version and built-in EPROM version can be read or programmed with a general purpose PROM programmer using a special programming adapter. Set the address of PROM programmer in the user ROM area.

Table. 8. Special programming adapter

Package	Name of Programming Adapter
80P6N-A	PCA4738F-80A
80D0	PCA4738L-80A

The PROM of the blank One Time PROM version is not tested or screened in the assembly process and following processes. To ensure proper operation after programming, the procedure shown in Figure 64 is recommended to verify programming.

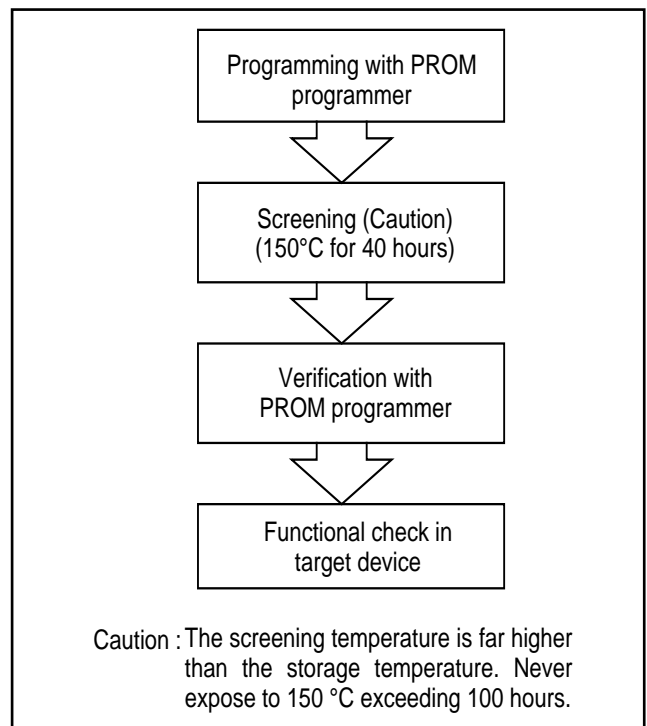

Fig. 62. Programming and testing of One Time PROM version

ELECTRICAL CHARACTERISTICS

ABSOLUTE MAXIMUM RATINGS

Table 9 Absolute maximum ratings

Symbol	Parameter	Conditions	Ratings	Unit
V _{CC}	Power source voltage	All voltages are based on V _{SS} . Output transistors are cut off.	-0.3 to 7.0	V
CMPV _{CC}	Analog comparator power source voltage		-0.3 to 7.0	V
V _I	Input voltage P00-P07, P10-P17, P20-P27, P30-P37, P40-P47, P50-P57, P60-P65, P70-P77, P80-P87, ADVREF		-0.3 to V _{CC} +0.3	V
V _I	Input voltage RESET, X _{IN}		-0.3 to V _{CC} +0.3	V
V _I	Input voltage CNV _{SS} (ROM version)		-0.3 to 7	V
V _I	Input voltage CNV _{SS} (PROM version)		-0.3 to 13	V
V _I	In-phase input voltage CMP _{IN} , CMP _{REF}		-0.3 to CMPV _{CC} +0.3	V
V _{ID}	Differential input voltage CMP _{IN} -CMP _{REF}		CMPV _{CC}	V
V _O	Output voltage P00-P07, P10-P17, P20-P27, P30-P37, P40-P47, P50-P57, P60-P62, P65, P70-P77, P80-P87, X _{OUT}		-0.3 to V _{CC} +0.3	V
V _O	Output voltage CMP _{OUT}		-0.3 to CMPV _{CC} +0.3	V
P _d	Power dissipation	T _a = 25°C	500	mW
T _{opr}	Operating temperature		-20 to 85	°C
T _{stg}	Storage temperature		-40 to 125	°C

RECOMMENDED OPERATING CONDITIONS

Table 10 Recommended operating conditions (1) ($V_{CC} = 2.7$ to 5.5 V, $T_a = -20$ to 85 °C, unless otherwise noted)

Symbol	Parameter		Limits			Unit
			Min.	Typ.	Max.	
V _{CC}	Power source voltage	$f(X_{IN}) \leq 4.1\text{MHz}$	2.7	5.0	5.5	V
		$f(X_{IN}) = 8\text{MHz}$	4.0	5.0	5.5	V
V _{SS}	Power source voltage			0		V
ADVREF	A-D comparator reference voltage		2.0		V _{CC}	V
DAVREF	D-A comparator reference voltage		2.7		V _{CC}	V
CMPVCC	Analog comparator power source voltage			V _{CC}		V
AVSS	Analog power source voltage			0		V
V _{IA}	A-D comparator input voltage	AN ₀ —AN ₁₂	AV _{SS}		V _{CC}	V
V _{IH}	"H" input voltage	P ₀₀ —P ₀₇ , P ₁₀ —P ₁₇ , P ₃₀ , P ₃₁ , P ₃₃ —P ₃₇ , P ₄₀ —P ₄₇ , P ₅₀ —P ₅₇ , P ₆₀ —P ₆₅ , P ₇₀ —P ₇₇ , P ₈₀ —P ₈₇	0.8V _{CC}		V _{CC}	V
V _{IH}	"H" input voltage (CMOS input level selected)	P ₂₀ —P ₂₇ , P ₃₂	0.8V _{CC}		V _{CC}	V
V _{IH}	"H" input voltage (TTL input level selected)	P ₂₀ —P ₂₇ , P ₃₂ (Note)	2.0		V _{CC}	V
V _{IH}	"H" input voltage	RESET, X _{IN} , CNV _{SS}	0.8V _{CC}		V _{CC}	V
V _{IL}	"L" input voltage	P ₀₀ —P ₀₇ , P ₁₀ —P ₁₇ , P ₃₀ , P ₃₁ , P ₃₃ —P ₃₇ , P ₄₀ —P ₄₇ , P ₅₀ —P ₅₇ , P ₆₀ —P ₆₅ , P ₇₀ —P ₇₇ , P ₈₀ —P ₈₇	0		0.2V _{CC}	V
V _{IL}	"L" input voltage (CMOS input level selected)	P ₂₀ —P ₂₇ , P ₃₂	0		0.2V _{CC}	V
V _{IL}	"L" input voltage (TTL input level selected)	P ₂₀ —P ₂₇ , P ₃₂ (Note)	0		0.8	V
V _{IL}	"L" input voltage	RESET, CNV _{SS}	0		0.2V _{CC}	V
V _{IL}	"L" input voltage	X _{IN}	0		0.16V _{CC}	V

Note: When V_{CC} is 4.0 to 5.5 V.

Table 11 Recommended operating conditions (2) ($V_{CC} = 2.7$ to 5.5 V, $T_a = -20$ to 85 °C, unless otherwise noted)

Symbol	Parameter		Limits			Unit
			Min.	Typ.	Max.	
$\Sigma I_{OH(peak)}$	"H" total peak output current (Note)	P ₀₀ —P ₀₇ , P ₁₀ —P ₁₇ , P ₂₀ —P ₂₇ , P ₃₀ —P ₃₇ , P ₈₀ —P ₈₇			-80	mA
$\Sigma I_{OH(peak)}$	"H" total peak output current (Note)	P ₄₀ —P ₄₇ , P ₅₀ —P ₅₇ , P ₆₀ —P ₆₂ , P ₆₅ , CMP _{OUT} , P ₇₀ —P ₇₇			-80	mA
$\Sigma I_{OL(peak)}$	"L" total peak output current (Note)	P ₀₀ —P ₀₇ , P ₁₀ —P ₁₇ , P ₂₀ —P ₂₃ , P ₃₀ —P ₃₇ , P ₈₀ —P ₈₇			80	mA
$\Sigma I_{OL(peak)}$	"L" total peak output current (Note) P ₂₄ —P ₂₇	in single chip mode			80	mA
		in memory expansion mode and microprocessor mode			80	mA
$\Sigma I_{OL(peak)}$	"L" total peak output current (Note)	P ₄₀ —P ₄₇ , P ₅₀ —P ₅₇ , P ₆₀ —P ₆₂ , P ₆₅ , CMP _{OUT} , P ₇₀ —P ₇₇			80	mA
$\Sigma I_{OH(avg)}$	"H" total average output current (Note)	P ₀₀ —P ₀₇ , P ₁₀ —P ₁₇ , P ₂₀ —P ₂₇ , P ₃₀ —P ₃₇ , P ₈₀ —P ₈₇			-40	mA
$\Sigma I_{OH(avg)}$	"H" total average output current (Note)	P ₄₀ —P ₄₇ , P ₅₀ —P ₅₇ , P ₆₀ —P ₆₂ , P ₆₅ , CMP _{OUT} , P ₇₀ —P ₇₇			-40	mA
$\Sigma I_{OL(avg)}$	"L" total average output current (Note)	P ₀₀ —P ₀₇ , P ₁₀ —P ₁₇ , P ₂₀ —P ₂₃ , P ₃₀ —P ₃₇ , P ₈₀ —P ₈₇			40	mA
$\Sigma I_{OL(avg)}$	"L" total average output current (Note) P ₂₄ —P ₂₇	in single chip mode			40	mA
		in memory expansion mode and microprocessor mode			40	mA
$\Sigma I_{OL(avg)}$	"L" total average output current (Note)	P ₄₀ —P ₄₇ , P ₅₀ —P ₅₇ , P ₆₀ —P ₆₂ , P ₆₅ , CMP _{OUT} , P ₇₀ —P ₇₇			40	mA

Note: The total output current is the sum of all the currents flowing through all the applicable ports. The total average current is an average value measured over 100ms. The total peak current is the peak value of all the currents.

SINGLE-CHIP 8-BIT CMOS MICROCOMPUTER

Table 12 Recommended operating conditions (3) ($V_{CC} = 2.7$ to 5.5 V, $T_a = -20$ to 85 °C, unless otherwise noted)

Symbol	Parameter		Limits			Unit	
			Min.	Typ.	Max.		
I _{OH} (peak)	"H" peak output current (Note 1)	P00–P07, P10–P17, P20–P27, P30–P37, P40–P47, P50–P57, P60–P62, P65, CMP _{OUT} , P70–P77, P80–P87			–10	mA	
I _{OL} (peak)	"L" peak output current (Note 1)	P00–P07, P10–P17, P20–P23, P30–P37, P40–P47, P50–P57, P60–P62, P65, CMP _{OUT} , P70–P77, P80–P87			10	mA	
I _{OL} (peak)	"L" peak output current (Note 1) P24–P27	in single chip mode			20	mA	
		in memory expansion mode and microprocessor mode			10	mA	
I _{OH} (avg)	"H" average output current (Note 2)	P00–P07, P10–P17, P20–P27, P30–P37, P40–P47, P50–P57, P60–P62, P65, CMP _{OUT} , P70–P77, P80–P87			–5	mA	
I _{OL} (avg)	"L" average output current (Note 2)	P00–P07, P10–P17, P20–P23, P30–P37, P40–P47, P50–P57, P60–P62, P65, CMP _{OUT} , P70–P77, P80–P87			5	mA	
I _{OL} (avg)	"L" average output current (Note 2) P24–P27	in single chip mode			15	mA	
		in memory expansion mode and microprocessor mode			5	mA	
f(X _{IN})	Main clock input oscillation frequency (Note 3)	High-speed mode $4.0V \leq V_{CC} \leq 5.5V$			8	MHz	
		High-speed mode $2.7V \leq V_{CC} \leq 4.0V$			3V _{CC} –4	MHz	
		Middle-speed mode $4.0V \leq V_{CC} \leq 5.5V$			8	MHz	
		Middle-speed mode (Note 5) $2.7V \leq V_{CC} \leq 4.0V$			8	MHz	
		Middle-speed mode (Note 5) $2.7V \leq V_{CC} \leq 4.0V$			3V _{CC} –4	MHz	
f(X _{CIN})	Sub-clock input oscillation frequency (Note 3, 4)				32.768	50	kHz

Note 1: The peak output current is the peak current flowing in each port.

2: The average output current I_{OL} (avg), I_{OH} (avg) in an average value measured over 100ms.

3: When the oscillation frequency has a duty cycle of 50%.

4: When using the microcomputer in low-speed mode, set the sub-clock input oscillation frequency on condition that $f(X_{CIN}) < f(X_{IN})/3$.

5: When using the timer X/Y, timer A/B (real time output port), timer 1/2/3, serial I/O1, serial I/O2, and A-D converter, set the main clock input oscillation frequency to the max. 3 V_{CC}–4 (MHz).

ELECTRICAL CHARACTERISTICS

Table 13 Electrical characteristics (1) ($V_{CC} = 2.7$ to 5.5 V, $V_{SS} = 0$ V, $T_a = -20$ to 85 °C, unless otherwise noted)

Symbol	Parameter	Test conditions	Limits			Unit
			Min.	Typ.	Max.	
VOH	"H" output voltage P00–P07, P10–P17, P20–P27, P30–P37, P40–P47, P50–P57, P60–P62, P65, P70–P77, P80–P87, CMP _{OUT} (Note 1)	I _{OH} = –10mA V _{CC} = 4.0 to 5.5V	V _{CC} –2.0			V
		I _{OH} = –1.0mA V _{CC} = 2.7 to 5.5V	V _{CC} –1.0			V
VOL	"L" output voltage P00–P07, P10–P17, P20–P27, P30–P37, P40–P47, P50–P57, P60–P62, P65, P70–P77, P80–P87, CMP _{OUT}	I _{OL} = 10mA V _{CC} = 4.0 to 5.5V			2.0	V
		I _{OL} = 1.6mA V _{CC} = 2.7 to 5.5V			0.4	V
V _{T+} –V _{T–}	Hysteresis P42, P43, P51–P55, P73 (Note 2), CNTR ₀ , CNTR ₁ , INT ₀ –INT ₄ , ADT			0.4		V
V _{T+} –V _{T–}	Hysteresis RXD, SCLK ₁ , SIN ₂ , SCLK ₂			0.5		V
V _{T+} –V _{T–}	Hysteresis RESET			0.5		V
I _{IH}	"H" input current P00–P07, P10–P17, P20–P27, P30–P37, P40–P47, P50–P57, P60–P65, P70–P77, P80–P87	V _I = V _{CC} (Pin floating. Pull-up transistors "off")			5.0	μA
I _{IH}	"H" input current RESET, CNV _{SS}	V _I = V _{CC}			5.0	μA
I _{IH}	"H" input current XIN	V _I = V _{CC}		4		μA
I _{IL}	"L" input current P00–P07, P10–P17, P20–P27, P30–P37, P40–P47, P50–P57, P60–P65, P70–P77, P80–P87	V _I = V _{SS} (Pin floating. Pull-up transistors "off")			–5.0	μA
I _{IL}	"L" input current RESET, CNV _{SS}	V _I = V _{SS}			–5.0	μA
I _{IL}	"L" input current XIN	V _I = V _{SS}		–4		μA
I _{IL}	"L" input current P00–P07, P10–P17, P20–P27	Pull-up transistors "on" V _I = V _{SS}		–0.2		mA
V _{RAM}	RAM hold voltage	When clock stopped	2.0		5.5	V

Note 1: P45 is measured when the P45/TxD P-channel output disable bit of the UART control register (bit 4 of address 001B16) is "0".
P71, and P12 are measured when the P71/SOUT2 and P72/SCLK2 P-channel output disable bit of the serial I/O2 control register 1 (bit 7 of address 001D16).

2: P73 is measured when the AD external trigger valid bit of the A–D control register (bit 6 of address 003416) is "1".

SINGLE-CHIP 8-BIT CMOS MICROCOMPUTER

Table 14 Electrical characteristics (2) (V_{CC} = 2.7 to 5.5 V, V_{SS} = 0 V, T_a = - 20 to 85 °C, unless otherwise noted)

Symbol	Parameter	Test conditions	Limits			Unit
			Min.	Typ.	Max.	
I _{CC}	Power source current	High-speed mode f(X _{IN}) = 8MHz f(X _{CIN}) = 32.768kHz Output transistors "off"		6.8	13	mA
		High-speed mode f(X _{IN}) = 8MHz (in WIT state) f(X _{CIN}) = 32.768kHz Output transistors "off"		1.6		mA
		Low-speed mode f(X _{IN}) = stopped f(X _{CIN}) = 32.768kHz Low-power dissipation mode (CM ₃ = 0) Output transistors "off"		60	200	μA
		Low-speed mode f(X _{IN}) = stopped f(X _{CIN}) = 32.768kHz (in WIT state) Low-power dissipation mode (CM ₃ = 0) Output transistors "off"		20	40	μA
		Low-speed mode (V _{CC} = 3V) f(X _{IN}) = stopped f(X _{CIN}) = 32.768kHz Low-power dissipation mode (CM ₃ = 0) Output transistors "off"		20	55	μA
		Low-speed mode (V _{CC} = 3V) f(X _{IN}) = stopped f(X _{CIN}) = 32.768kHz (in WIT state) Low-power dissipation mode (CM ₃ = 0) Output transistors "off"		5.0	10.0	μA
		Middle-speed mode f(X _{IN}) = 8MHz f(X _{CIN}) = stopped Output transistors "off"		4.0	7.0	mA
		Middle-speed mode f(X _{IN}) = 8MHz (in WIT state) f(X _{CIN}) = stopped Output transistors "off"		1.5		mA
		Increment when A-D conversion is executed f(X _{IN}) = 8MHz		800		μA
		All oscillation stopped (in STP state) Output transistors "off"	T _a = 25°C		0.1	1.0
	T _a = 85°C			10	μA	
CMPI _{CC}	Analog comparator Power source current		200	500	μA	

A-D CONVERTER CHARACTERISTICS

Table 15 A-D converter characteristics

(V_{CC} = 2.7 to 5.5 V, V_{SS} = AV_{SS} = 0 V, ADV_{REF} = 2.0 V to V_{CC}, T_a = - 20 to 85 °C, unless otherwise noted)

Symbol	Parameter		Test conditions	Limits			Unit
				Min.	Typ.	Max.	
—	Resolution					8	Bits
—	Absolute accuracy (excluding quantization error)		V _{CC} = ADV _{REF} = 5.0V			±2	LSB
t _{CONV}	Conversion time					50	tc(φ)
RLADDER	Ladder resistor			12	35	100	kΩ
I _{ADVREF}	Reference power source input current	ADV _{REF} "on"	ADV _{REF} = 5.0V	50	150	200	μA
		ADV _{REF} "off"				5	μA
I _{I(AD)}	A-D port input current					5.0	μA

D-A CONVERTER CHARACTERISTICS

Table 16 D-A converter characteristics

(V_{CC} = 2.7 to 5.5 V, V_{SS} = AV_{SS} = 0 V, DAV_{REF} = 2.7 V to V_{CC}, T_a = - 20 to 85 °C, unless otherwise noted)

Symbol	Parameter		Test conditions	Limits			Unit
				Min.	Typ.	Max.	
—	Resolution					8	Bits
—	Absolute accuracy	V _{CC} = 4.0 to 5.5V				1.0	%
		V _{CC} = 2.7 to 4.0V				2.5	%
t _{su}	Setting time					3	μs
R _o	Output resistor			1	2.5	4	kΩ
I _{DAVREF}	Reference power source input current (Note)					3.2	mA

Note: Using one D-A converter, with the value in the D-A conversion register of the other D-A converter being "0016".

ANALOG COMPARATOR CHARACTERISTICS

Table 17 Analog comparator characteristics

(V_{CC} = 2.7 to 5.5 V, V_{SS} = AV_{SS} = 0 V, CMPV_{CC} = 2.7 V to V_{CC}, T_a = - 20 to 85 °C, unless otherwise noted)

Symbol	Parameter		Test conditions	Limits			Unit
				Min.	Typ.	Max.	
V _{IO}	Input offset voltage		CMPV _{CC} = 5.0V CMP _{PREF} = 2.5V, R _s = 0Ω		3	50	mV
I _B	Input bias current					5	μA
I _{IO}	Input offset current					5	μA
V _{ICM}	In-phase input voltage range			1.2		CMPV _{CC} -0.5	V
A _V	Voltage gain				∞		
t _{PD}	Response time		CMPV _{CC} = 5.0V CMP _{PREF} = 2.5V		60	2500	ns

TIMING REQUIREMENTS

Table 18 Timing requirements (1) (Vcc = 4.0 to 5.5 V, Vss = 0 V, Ta = - 20 to 85 °C, unless otherwise noted)

Symbol	Parameter	Limits			Unit
		Min.	Typ.	Max.	
t _w (RESET)	Reset input "L" pulse width	2			μs
t _c (XIN)	External clock input cycle time	125			ns
t _{WH} (XIN)	External clock input "H" pulse width	50			ns
t _{WL} (XIN)	External clock input "L" pulse width	50			ns
t _c (CNTR)	CNTR ₀ , CNTR ₁ input cycle time	200			ns
t _{WH} (CNTR)	CNTR ₀ , CNTR ₁ input "H" pulse width	80			ns
t _{WL} (CNTR)	CNTR ₀ , CNTR ₁ input "L" pulse width	80			ns
t _{WH} (INT)	INT ₀ to INT ₄ input "H" pulse width	80			ns
t _{WL} (INT)	INT ₀ to INT ₄ input "L" pulse width	80			ns
t _c (SCLK1)	Serial I/O1 clock input cycle time (Note)	800			ns
t _{WH} (SCLK1)	Serial I/O1 clock input "H" pulse width (Note)	370			ns
t _{WL} (SCLK1)	Serial I/O1 clock input "L" pulse width (Note)	370			ns
t _{su} (RXD-SCLK1)	Serial I/O1 clock input set up time	220			ns
t _h (SCLK1-RXD)	Serial I/O1 clock input hold time	100			ns
t _c (SCLK2)	Serial I/O2 clock input cycle time	1000			ns
t _{WH} (SCLK2)	Serial I/O2 clock input "H" pulse width	400			ns
t _{WL} (SCLK2)	Serial I/O2 clock input "L" pulse width	400			ns
t _{su} (SIN2-SCLK2)	Serial I/O2 clock input set up time	200			ns
t _h (SCLK2-SIN2)	Serial I/O2 clock input hold time	200			ns

Note: When bit 6 of address 001A16 is "1" (clock synchronous).
Divide this value by four when bit 6 of address 001A16 is "0" (UART).

Table 19 Timing requirements (2) (Vcc = 2.7 to 5.5 V, Vss = 0 V, Ta = - 20 to 85 °C, unless otherwise noted)

Symbol	Parameter	Limits			Unit
		Min.	Typ.	Max.	
t _w (RESET)	Reset input "L" pulse width	2			μs
t _c (XIN)	External clock input cycle time	243			ns
t _{WH} (XIN)	External clock input "H" pulse width	100			ns
t _{WL} (XIN)	External clock input "L" pulse width	100			ns
t _c (CNTR)	CNTR ₀ , CNTR ₁ input cycle time	500			ns
t _{WH} (CNTR)	CNTR ₀ , CNTR ₁ input "H" pulse width	230			ns
t _{WL} (CNTR)	CNTR ₀ , CNTR ₁ input "L" pulse width	230			ns
t _{WH} (INT)	INT ₀ to INT ₄ input "H" pulse width	230			ns
t _{WL} (INT)	INT ₀ to INT ₄ input "L" pulse width	230			ns
t _c (SCLK1)	Serial I/O1 clock input cycle time (Note)	2000			ns
t _{WH} (SCLK1)	Serial I/O1 clock input "H" pulse width (Note)	950			ns
t _{WL} (SCLK1)	Serial I/O1 clock input "L" pulse width (Note)	950			ns
t _{su} (RXD-SCLK1)	Serial I/O1 clock input set up time	400			ns
t _h (SCLK1-RXD)	Serial I/O1 clock input hold time	200			ns
t _c (SCLK2)	Serial I/O2 clock input cycle time	2000			ns
t _{WH} (SCLK2)	Serial I/O2 clock input "H" pulse width	950			ns
t _{WL} (SCLK2)	Serial I/O2 clock input "L" pulse width	950			ns
t _{su} (SIN2-SCLK2)	Serial I/O2 clock input set up time	400			ns
t _h (SCLK2-SIN2)	Serial I/O2 clock input hold time	300			ns

Note: When bit 6 of address 001A16 is "1" (clock synchronous).
Divide this value by four when bit 6 of address 001A16 is "0" (UART).

SWITCHING CHARACTERISTICS

Table 20 Switching characteristics (1) ($V_{CC} = 4.0$ to 5.5 V, $V_{SS} = 0$ V, $T_a = -20$ to 85 °C, unless otherwise noted)

Symbol	Parameter	Test conditions	Limits			Unit
			Min.	Typ.	Max.	
t _{WH} (SCLK1)	Serial I/O1 clock output "H" pulse width	Fig. 3.1.1	tc(SCLK1)/2-30			ns
t _{WL} (SCLK1)	Serial I/O1 clock output "L" pulse width		tc(SCLK1)/2-30			ns
t _d (SCLK1-TxD)	Serial I/O1 output delay time (Note 1)				140	ns
t _v (SCLK1-TxD)	Serial I/O1 output valid time (Note 1)		-30			ns
t _r (SCLK1)	Serial I/O1 clock output rising time				30	ns
t _f (SCLK1)	Serial I/O1 clock output falling time				30	ns
t _{WH} (SCLK2)	Serial I/O2 clock output "H" pulse width	Fig. 3.1.1	tc(SCLK2)/2-160			ns
t _{WL} (SCLK2)	Serial I/O2 clock output "L" pulse width		tc(SCLK2)/2-160			ns
t _d (SCLK2-SOUT2)	Serial I/O2 output delay time (Note 2)				200	ns
t _v (SCLK2-SOUT2)	Serial I/O2 output valid time (Note 2)		0			ns
t _f (SCLK2)	Serial I/O2 clock output falling time				30	ns
t _r (CMOS)	CMOS output rising time (Note 3)		Fig. 3.1.1		10	30
t _f (CMOS)	CMOS output falling time (Note 3)			10	30	ns

Note 1: When the P45/TxD P-channel output disable bit of the UART control register (bit 4 of address 001B16) is "0".

2: When the P71/SOUT2, P72/SCLK2 P-channel output disable bit of the serial I/O2 control register1 (bit 7 of address 001D16) is "0".

3: XOUT pin is excluded.

Table 21 Switching characteristics (2) ($V_{CC} = 2.7$ to 5.5 V, $V_{SS} = 0$ V, $T_a = -20$ to 85 °C, unless otherwise noted)

Symbol	Parameter	Test conditions	Limits			Unit
			Min.	Typ.	Max.	
t _{WH} (SCLK1)	Serial I/O1 clock output "H" pulse width	Fig. 3.1.1	tc(SCLK1)/2-50			ns
t _{WL} (SCLK1)	Serial I/O1 clock output "L" pulse width		tc(SCLK1)/2-50			ns
t _d (SCLK1-TxD)	Serial I/O1 output delay time (Note 1)				350	ns
t _v (SCLK1-TxD)	Serial I/O1 output valid time (Note 1)		-30			ns
t _r (SCLK1)	Serial I/O1 clock output rising time				50	ns
t _f (SCLK1)	Serial I/O1 clock output falling time				50	ns
t _{WH} (SCLK2)	Serial I/O2 clock output "H" pulse width	Fig. 3.1.1	tc(SCLK2)/2-240			ns
t _{WL} (SCLK2)	Serial I/O2 clock output "L" pulse width		tc(SCLK2)/2-240			ns
t _d (SCLK2-SOUT2)	Serial I/O2 output delay time (Note 2)				400	ns
t _v (SCLK2-SOUT2)	Serial I/O2 output valid time (Note 2)		0			ns
t _f (SCLK2)	Serial I/O2 clock output falling time				50	ns
t _r (CMOS)	CMOS output rising time (Note 3)		Fig. 3.1.1		20	50
t _f (CMOS)	CMOS output falling time (Note 3)			20	50	ns

Note 1: When the P45/TxD P-channel output disable bit of the UART control register (bit 4 of address 001B16) is "0".

2: When the P71/SOUT2, P72/SCLK2 P-channel output disable bit of the serial I/O2 control register1 (bit 7 of address 001D16) is "0".

3: XOUT pin is excluded.

TIMING REQUIREMENTS IN MEMORY EXPANSION MODE AND MICROPROCESSOR MODE

Table 22 Timing requirements in memory expansion and microprocessor mode(1)

(Vcc = 4.0 to 5.5 V, Vss = 0 V, Ta = - 20 to 85 °C, in high-speed mode, unless otherwise noted)

Symbol	Parameter	Limits			Unit
		Min.	Typ.	Max.	
tsu(ONW-φ)	ONW input set up time	-20			ns
th(φ-ONW)	ONW input hold time	-20			ns
tsu(DB-φ)	Data bus set up time	50			ns
th(φ-DB)	Data bus hold time	0			ns
tsu(ONW-RD), tsu(ONW-WR)	ONW input set up time	-20			ns
th(RD-ONW), th(WR-ONW)	ONW input hold time	-20			ns
tsu(DB-RD)	Data bus set up time	50			ns
th(RD-DB)	Data bus hold time	0			ns

SWITCHING CHARACTERISTICS IN MEMORY EXPANSION MODE AND MICROPROCESSOR MODE

Table 23 Switching characteristics in memory expansion and microprocessor mode(1)

(Vcc = 4.0 to 5.5 V, Vss = 0 V, Ta = - 20 to 85 °C, in high-speed mode, unless otherwise noted)

Symbol	Parameter	Test conditions	Limits			Unit
			Min.	Typ.	Max.	
tc(φ)	φ clock cycle time	Fig. 3.1.1		2tc(XIN)		ns
tWH(φ)	φ clock "H" pulse width		tc(XIN)-10			ns
tWL(φ)	φ clock "L" pulse width		tc(XIN)-10			ns
td(φ-AH)	AD15-AD8 delay time			16	35	ns
td(φ-AL)	AD7-AD0 delay time			20	40	ns
tv(φ-AH)	AD15-AD8 valid time		2	5		ns
tv(φ-AL)	AD7-AD0 valid time		2	5		ns
td(φ-SYNC)	SYNC delay time			16		ns
tv(φ-SYNC)	SYNC valid time			5		ns
td(φ-DB)	Data bus delay time			15	30	ns
tv(φ-DB)	Data bus valid time		10			ns
tWL(RD), tWL(WR)	RD pulse width, WR pulse width		tc(XIN)-10			ns
	RD pulse width, WR pulse width (When one-wait is valid)		3tc(XIN)-10			ns
td(AH-RD), td(AH-WR)	AD15-AD8 delay time		tc(XIN)-35	tc(XIN)-16		ns
td(AL-RD), td(AL-WR)	AD7-AD0 delay time		tc(XIN)-40	tc(XIN)-20		ns
tv(RD-AH), tv(WR-AH)	AD15-AD8 valid time		2	5		ns
tv(RD-AL), tv(WR-AL)	AD7-AD0 valid time		2	5		ns
td(WR-DB)	Data bus delay time			15	30	ns
tv(WR-DB)	Data bus valid time		10			ns
td(RESET-RESETOUT)	RESETOUT output delay time				200	ns
tv(φ-RESETOUT)	RESETOUT output valid time (Note)	0		100	ns	

Note: The RESETOUT output goes "H" in sync with the fall of the φ clock that is anywhere between about 8 cycle and 13 cycles after the RESET input goes "H".

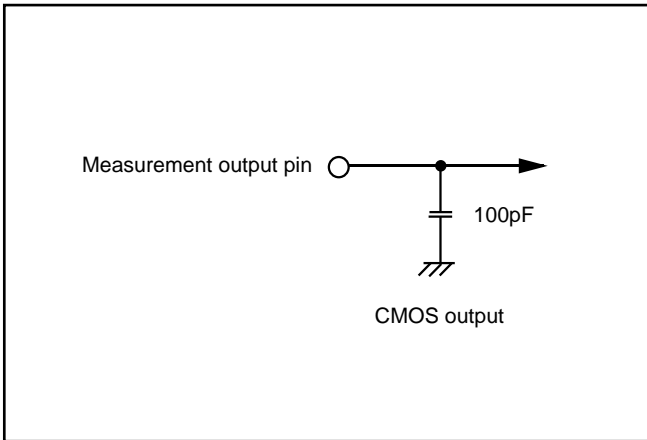

Fig. 63 Circuit for measuring output switching characteristics(1)

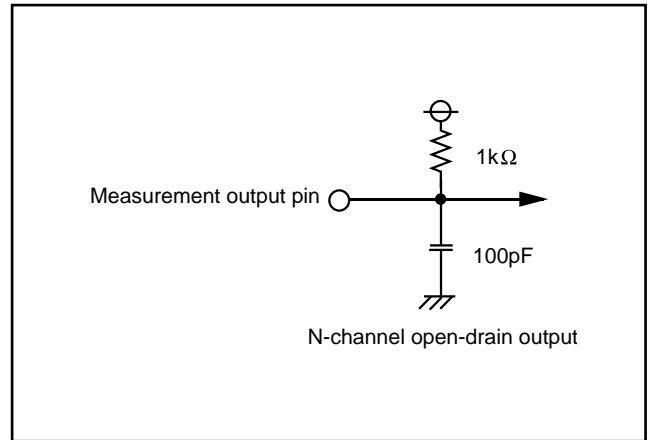

Fig. 64 Circuit for measuring output switching characteristics (2)

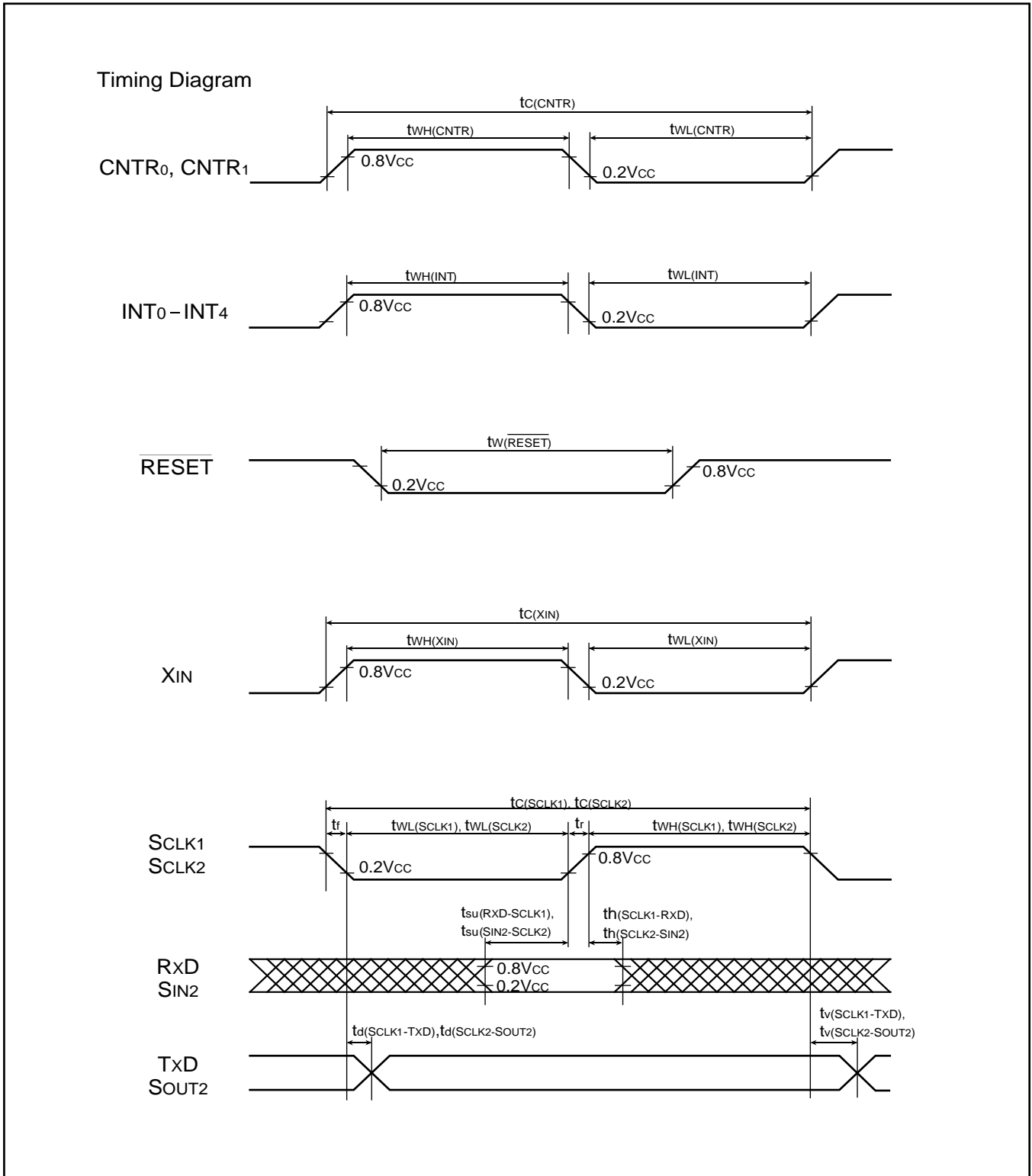
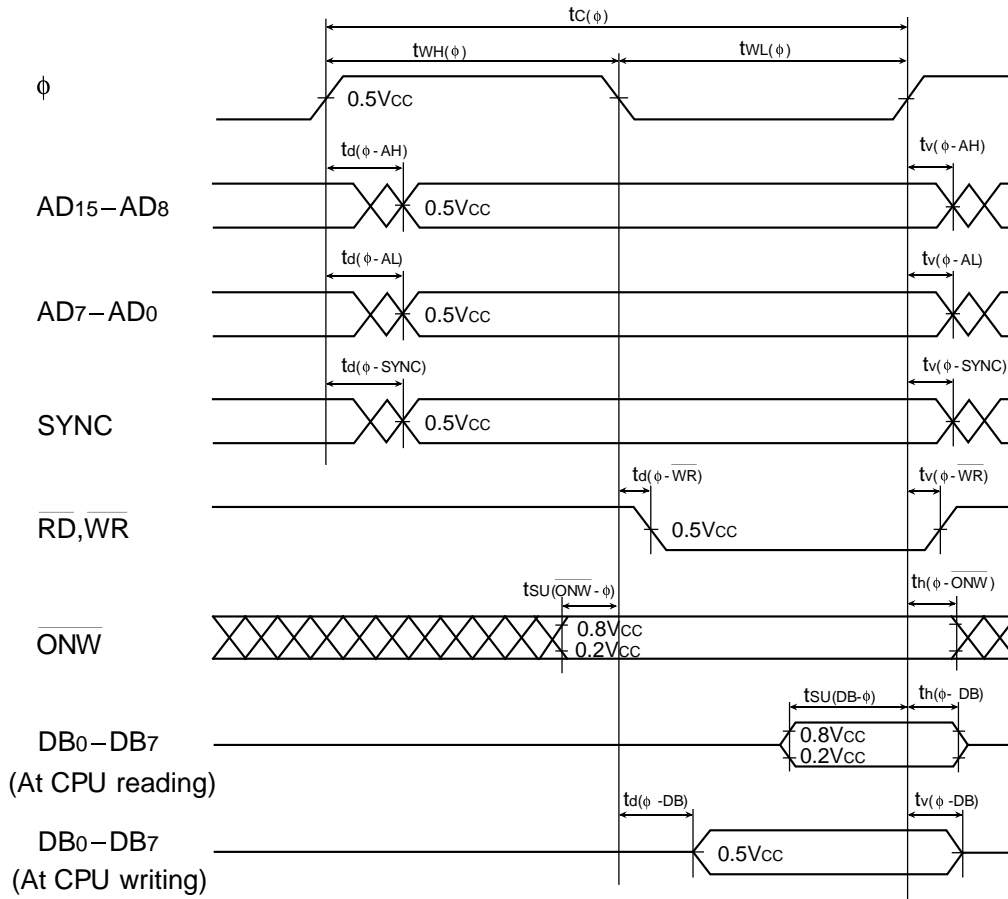

Fig. 65 Timing diagram (1) (in single-chip mode)

Timing Diagram in Memory Expansion Mode and Microprocessor Mode (CMOS level input)



Timing Diagram in Microprocessor Mode

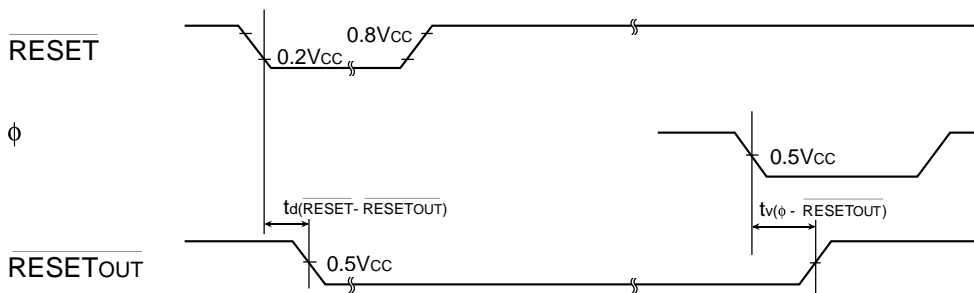

Fig. 66 Timing diagram (2) (in memory expansion mode and microprocessor mode)

Timing Diagram in Memory Expansion Mode and Microprocessor Mode (CMOS level input)

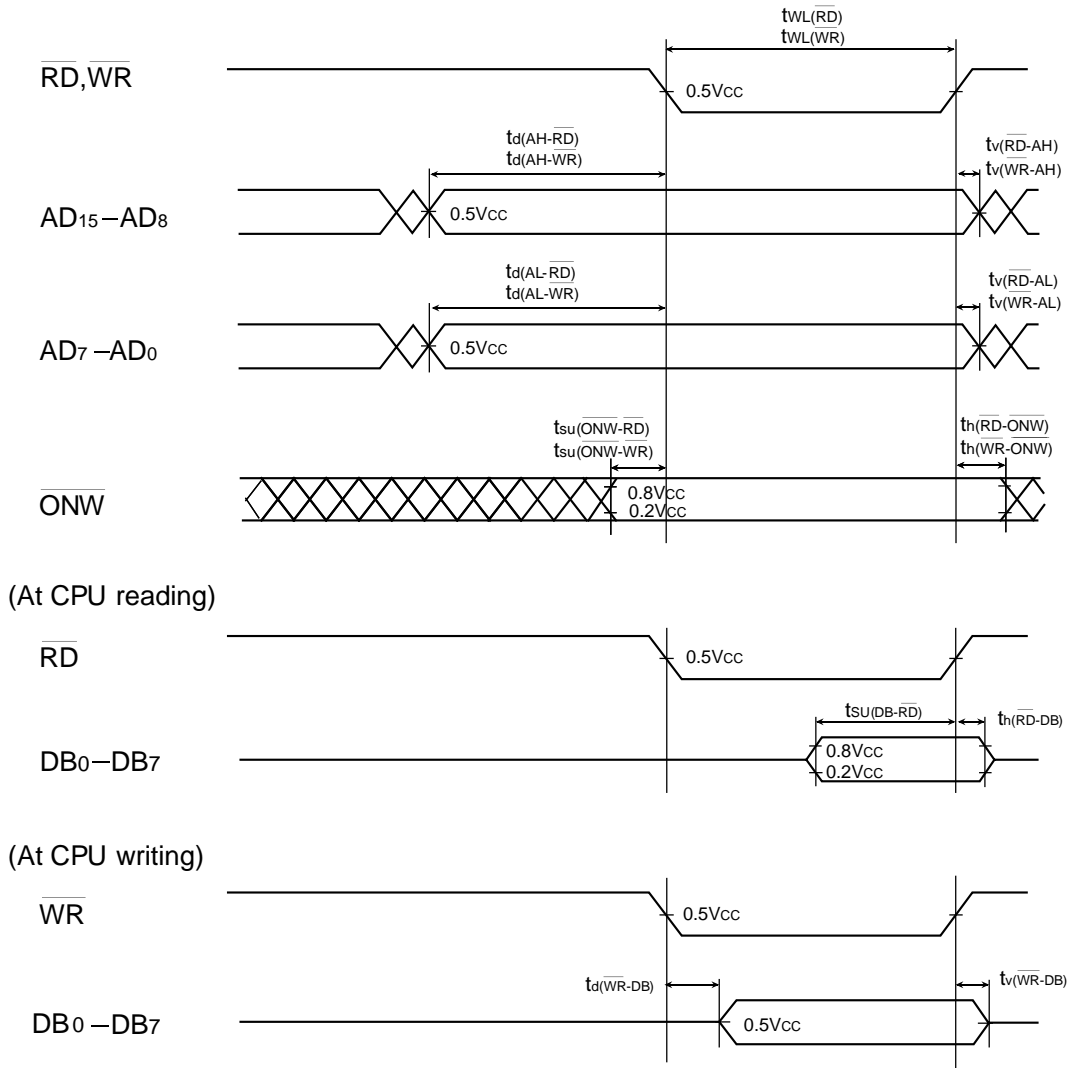
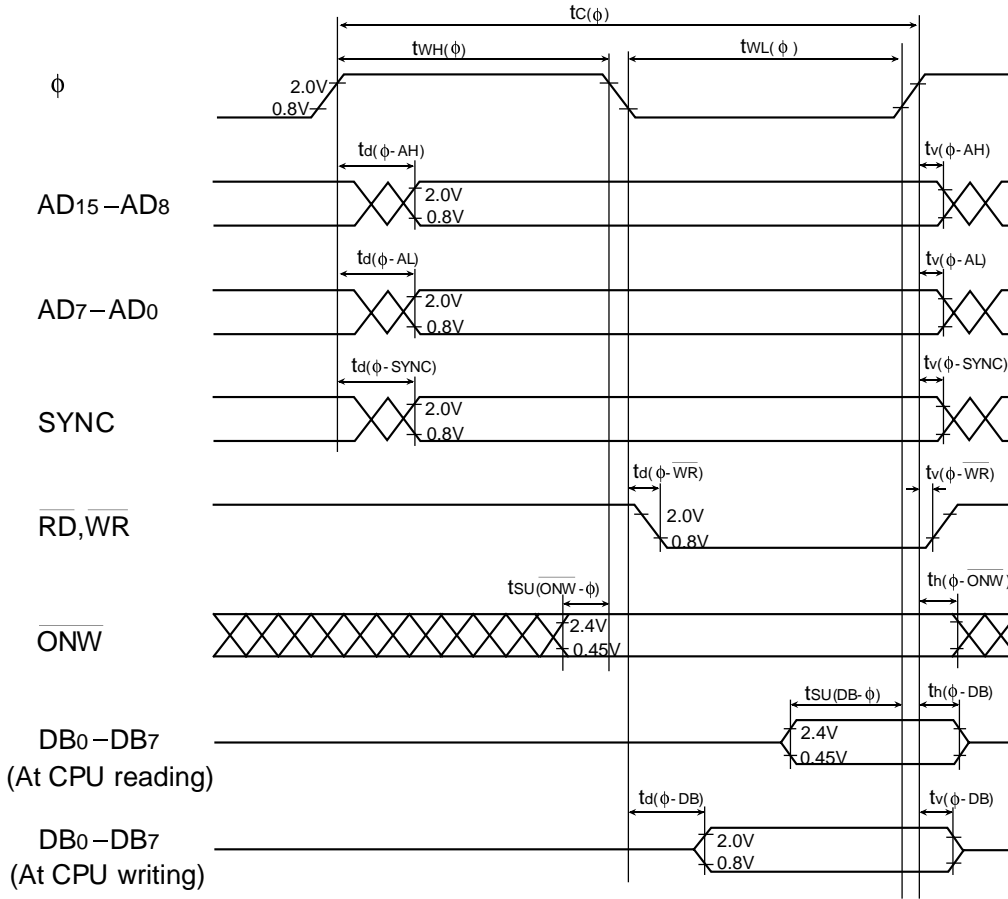

Fig. 67 Timing diagram (3) (in memory expansion mode and microprocessor mode)

Timing Diagram in Memory Expansion Mode and Microprocessor Mode (TTL level input)



Timing Diagram in Microprocessor Mode

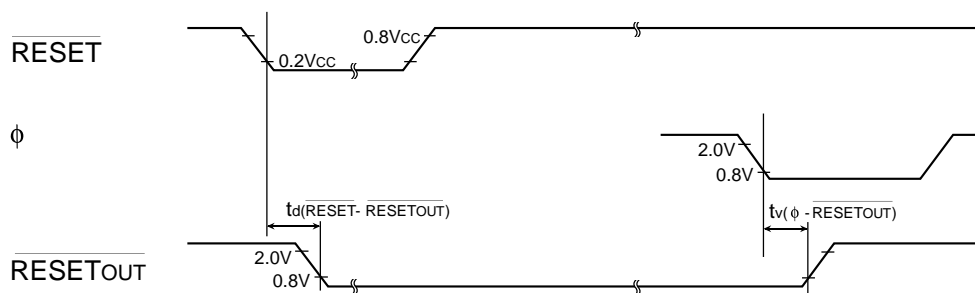

Fig. 68 Timing diagram (4) (in memory expansion mode and microprocessor mode)

Timing Diagram in Memory Expansion Mode and Microprocessor Mode (TTL level input)

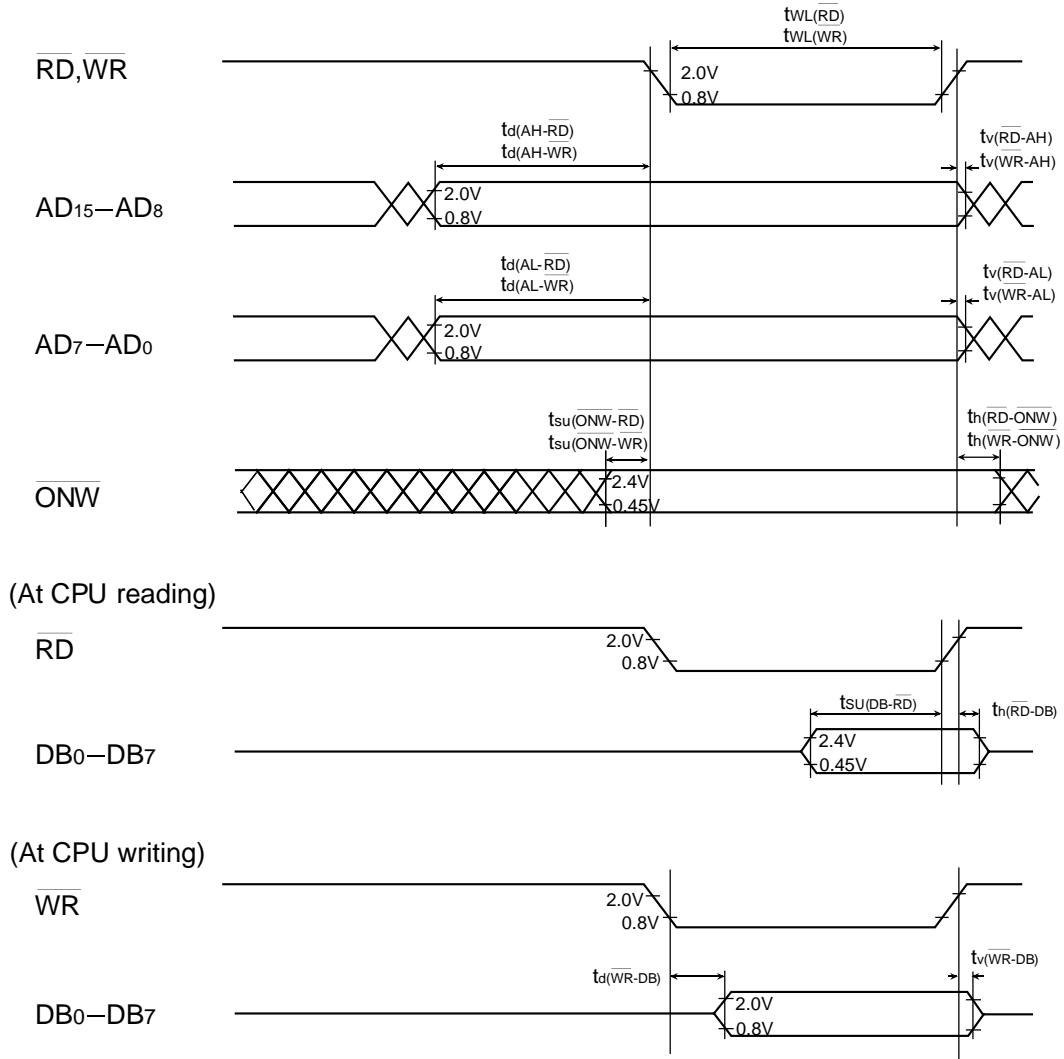

Fig. 69 Timing diagram (5) (in memory expansion mode and microprocessor mode)

Keep safety first in your circuit designs!

- Mitsubishi Electric Corporation puts the maximum effort into making semiconductor products better and more reliable, but there is always the possibility that trouble may occur with them. Trouble with semiconductors may lead to personal injury, fire or property damage. Remember to give due consideration to safety when making your circuit designs, with appropriate measures such as (i) placement of substitutive, auxiliary circuits, (ii) use of non-flammable material or (iii) prevention against any malfunction or mishap.

Notes regarding these materials

- These materials are intended as a reference to assist our customers in the selection of the Mitsubishi semiconductor product best suited to the customer's application; they do not convey any license under any intellectual property rights, or any other rights, belonging to Mitsubishi Electric Corporation or a third party.
- Mitsubishi Electric Corporation assumes no responsibility for any damage, or infringement of any third-party's rights, originating in the use of any product data, diagrams, charts or circuit application examples contained in these materials.
- All information contained in these materials, including product data, diagrams and charts, represent information on products at the time of publication of these materials, and are subject to change by Mitsubishi Electric Corporation without notice due to product improvements or other reasons. It is therefore recommended that customers contact Mitsubishi Electric Corporation or an authorized Mitsubishi Semiconductor product distributor for the latest product information before purchasing a product listed herein.
- Mitsubishi Electric Corporation semiconductors are not designed or manufactured for use in a device or system that is used under circumstances in which human life is potentially at stake. Please contact Mitsubishi Electric Corporation or an authorized Mitsubishi Semiconductor product distributor when considering the use of a product contained herein for any specific purposes, such as apparatus or systems for transportation, vehicular, medical, aerospace, nuclear, or undersea repeater use.
- The prior written approval of Mitsubishi Electric Corporation is necessary to reprint or reproduce in whole or in part these materials.
- If these products or technologies are subject to the Japanese export control restrictions, they must be exported under a license from the Japanese government and cannot be imported into a country other than the approved destination.
- Any diversion or reexport contrary to the export control laws and regulations of Japan and/or the country of destination is prohibited.
- Please contact Mitsubishi Electric Corporation or an authorized Mitsubishi Semiconductor product distributor for further details on these materials or the products contained therein.

REVISION DESCRIPTION LIST

3807 GROUP DATA SHEET

Rev. No.	Revision Description	Rev. date
1.0	First Edition	9711.30