

53217

SPST SOLID-STATE POWER CONTROLLERS

Mii

**MICROCIRCUITS PRODUCTS
DIVISION**

Features:

- Short circuit protection with status output
- SPST, normally open
- Up to 1000 V RMS isolation
- Output current up to 3 Amps DC
- Power FET output
- Low on-state resistance
- Full military temperature operation:
-55°C to +125°C
- Military environmental screening available

Applications:

- Ideal for 270V bus applications
- Aircraft Power Distribution
- Military/High Reliability Systems
- Satellite/Space Systems

DESCRIPTION

The 53217 is a military SPST high power, solid-state relay. It is a light-weight device resistant to damage from shock and vibration, and immune to contact-related problems (contamination, arcing) associated with mechanical equivalents.

Transformer coupling between the input and output stages provides effective isolation up to 1000 V RMS. The Power FET output eliminates bipolar offset and minimizes output voltage drop.

The control input may be driven by either CMOS or TTL logic, and the bias supply will accommodate 3.8 through 32 VDC. (See figures 1 & 2)

Integral short-circuit protection with status output is provided. These units sense excessive current flow while under load or while switching, and respond by opening the output. An open-collector status output is available to indicate that the short circuit protection has been activated. The output will remain blocked indefinitely until the short is removed and the unit reset. This feature prevents damage to the controller and also averts further system failures that may be caused by the short circuit. Status line output remains on until the relay is turned off for resetting. Resetting the unit can be accomplished by recycling the input control.

This device is available in a variety of quality levels from COTS to class K including any custom screening requirements. The basic data sheet part is environmentally screened to H level in accordance with Table C-IX of MIL-PRF-38534, which includes no element evaluation or QCI.

ABSOLUTE MAXIMUM RATINGS

Isolation voltage ¹	1000 V RMS
Continuous operating output voltage ³ : 53217	400 VDC
Load Current ² : 53217	3.0 A
Bias supply voltage, V _{DD}	3.8 to 32 VDC
Operating temperature	-55°C to +125°C Case
Storage temperature	-55°C to +125°C

Notes:

- ¹ 60 Hz sine wave
- ² At T_C = 125°C max
- ³ Reversing polarity on the output may cause permanent damage
- ⁴ Devices will not tolerate "short while on" at load voltages exceeding 28 VDC

Micropac Industries cannot assume any responsibility for any circuits shown or represent that they are free from patent infringement. **Micropac** reserves the right to make changes at any time in order to improve design and to supply the best product possible.

ELECTRICAL CHARACTERISTICS

 $T_A = +25^\circ\text{C}$

PARAMETER	TEST CONDITIONS	MIN	TYP	MAX	UNITS
Input characteristics					
CMOS configurations (Figure 1)					
Bias supply range, V_{DD}		3.8		32	VDC
Bias current			3	5	mA
Input current	5 VDC Input			250	μA
Control voltage range		3.8		18	VDC
Turn-off voltage				2.8	VDC
Turn-on voltage		0.5			VDC
Total Hysteresis			1.8		VDC
Dielectric strength	60 Hz	1000			V RMS
Input characteristics					
TTL configuration (Figure 2)					
Input current			3	5	mA
Control voltage range		3.8		32	VDC
Turn-off voltage	Note 5			1.5	VDC
Turn-on voltage	Note 5	3.8			VDC
Status on voltage	On at 5 mA SINKING CURRENT			0.4	Volts
Status off leakage	Off at 20 V			20	μA
Output characteristics					
Output current::	At $T_C = 125^\circ\text{C}$ case temperature			3.0	A
Continuous blocking voltage				400	VDC
On-state resistance, R_{ds}	25°C Case		0.50		Ohms
Turn-on time @ 25°C case			0.4	0.8	ms
Turn-off time @ 25°C case			0.5	2.0	ms
Off-state leakage	At Maximum Blocking Voltage		40	100	μA
Output Capacitance				700	pF
Short-circuit current	25°C		6		A
Short-circuit peak	Shorted while on at 25°C See Figure 3		100		A
Junction temperature				150	$^\circ\text{C}$
Thermal resistance, θ_{JA}				30	$^\circ\text{C/W}$
θ_{JC}				5	$^\circ\text{C/W}$

APPLICATION NOTES:

1. Maximum input switching frequency not to exceed 20 Hz under normal conditions, or 1 Hz if output is shorted.
2. Input transitions should be <1 ms and duration and input source should be "bounceless contact" type.
3. Inductive loads must be diode suppressed.
4. Peak current that may flow when output is shorted.
5. Devices will not tolerate "short while on" at load voltages exceeding 28 VDC.

Micropac Industries cannot assume any responsibility for any circuits shown or represent that they are free from patent infringement. Micropac reserves the right to make changes at any time in order to improve design and to supply the best product possible.

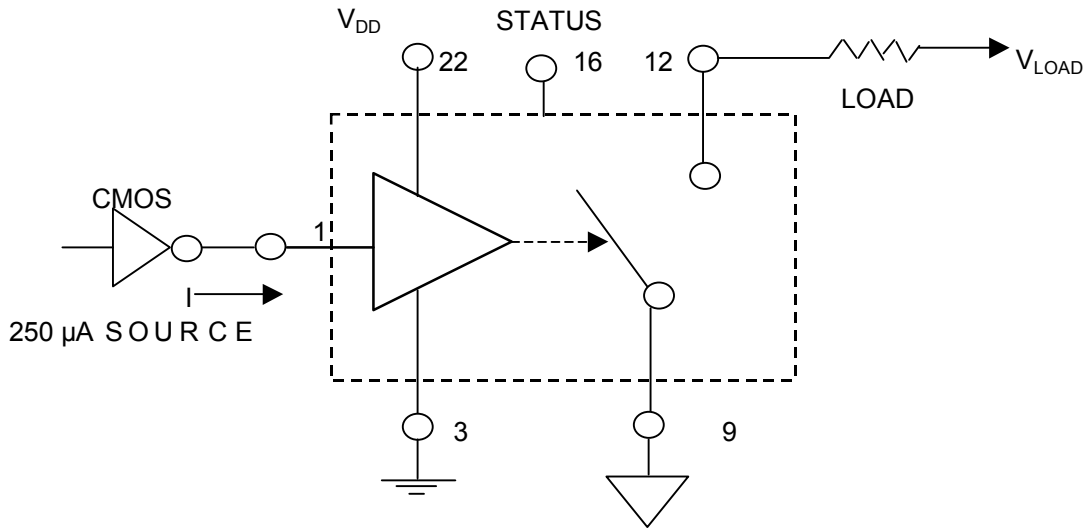

Figure 1 – CMOS Input Configuration

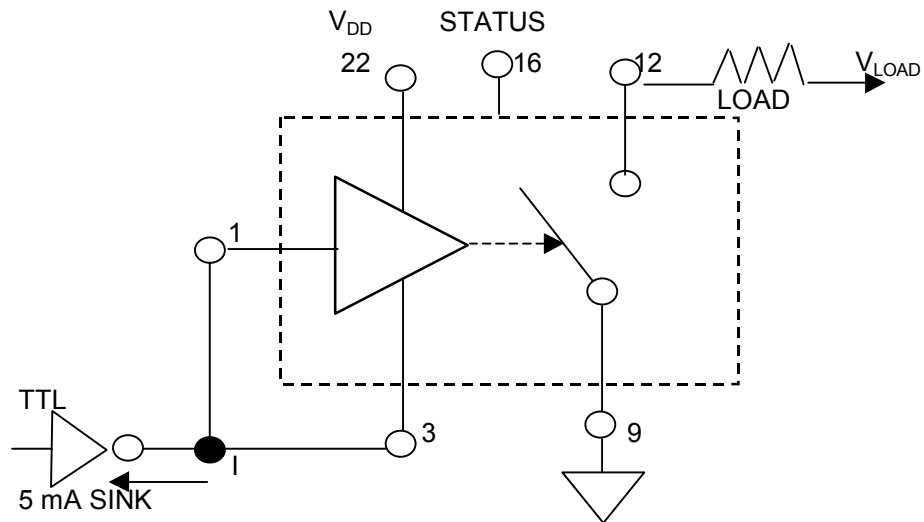

Figure 2 - TTL Open Collector Input Configuration (Low Side Switch)

Micropac Industries cannot assume any responsibility for any circuits shown or represent that they are free from patent infringement. Micropac reserves the right to make changes at any time in order to improve design and to supply the best product possible.

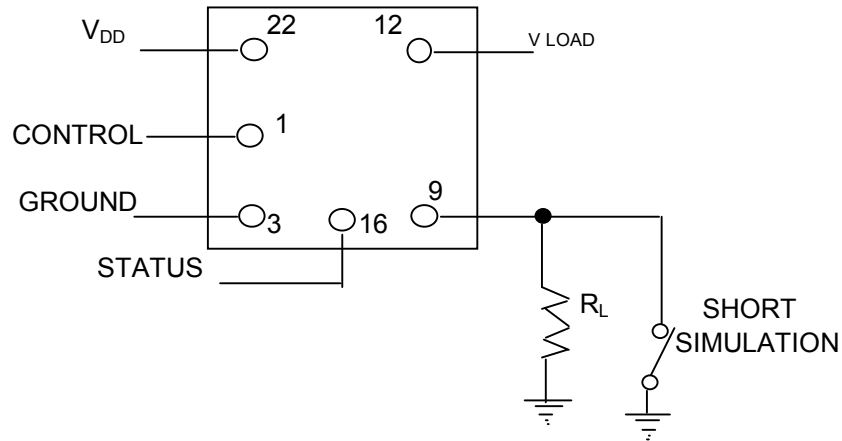

FIGURE 3 - BLOCK DIAGRAM (HIGH SIDE SWITCH)

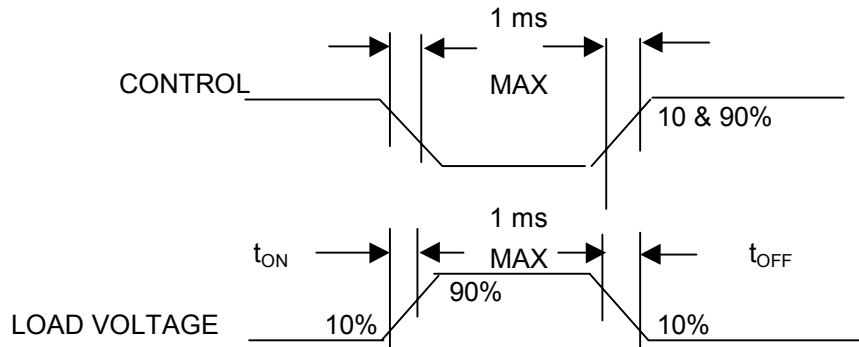

Figure 4 - SWITCHING CHARACTERISTICS

Micropac Industries cannot assume any responsibility for any circuits shown or represent that they are free from patent infringement. Micropac reserves the right to make changes at any time in order to improve design and to supply the best product possible.

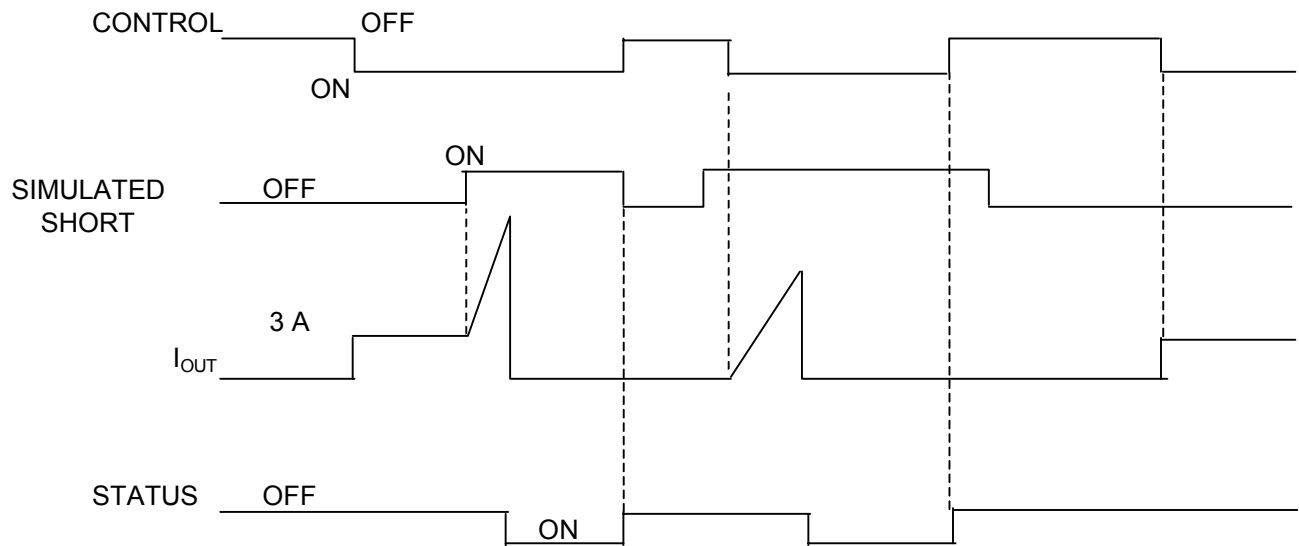
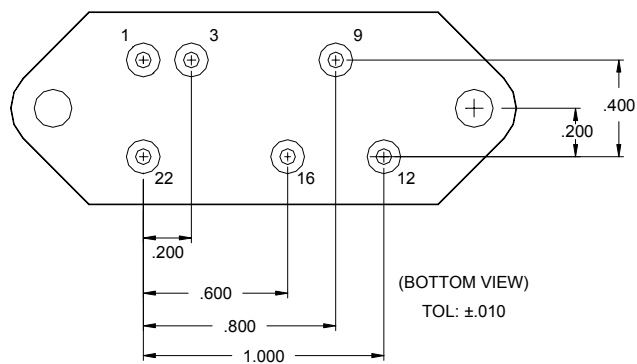
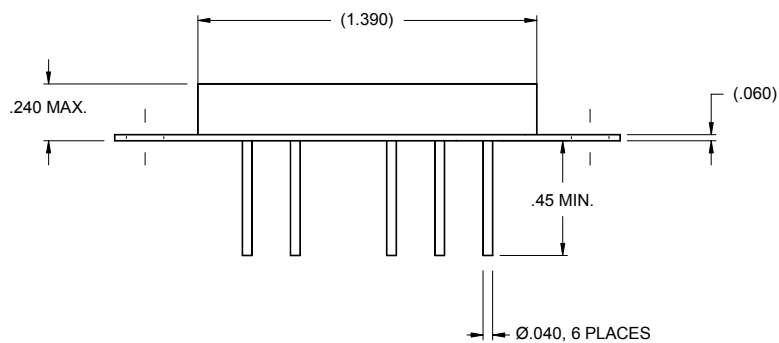
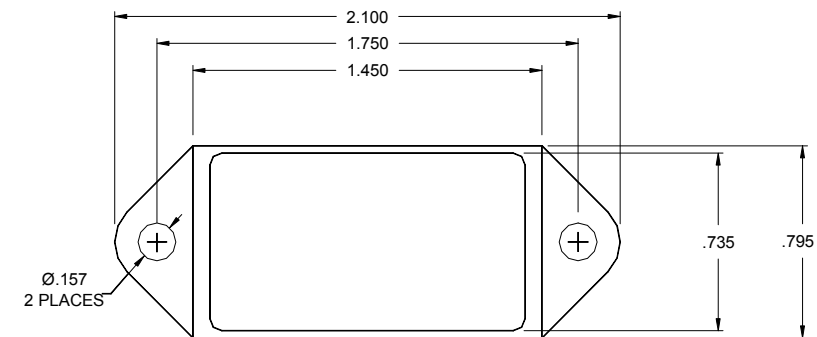

Figure 5 - TIMING DIAGRAM

Micropac Industries cannot assume any responsibility for any circuits shown or represent that they are free from patent infringement.
Micropac reserves the right to make changes at any time in order to improve design and to supply the best product possible.

Package Dimensions



IN	FUNCTION
1	Control
3	GND
9	-OUT
12	+OUT
16	Status
22	V_{DD}

Micropac Industries cannot assume any responsibility for any circuits shown or represent that they are free from patent infringement. Micropac reserves the right to make changes at any time in order to improve design and to supply the best product possible.