

LINEAR SYSTEMS

Linear Integrated Systems

LS4117, 4118, 4119 ULTRA-HIGH INPUT IMPEDANCE N-CANNEL JFET

FEATURES	
LOW POWER	$I_{DSS} < 90 \mu A$ (2N4117)
MINIMUM CIRCUIT LOADING	$I_{GSS} < 1 pA$ (2N4117A Series)
ABSOLUTE MAXIMUM RATINGS (NOTE 1)	
@ 25°C (unless otherwise noted)	
Gate-Source or Gate-Drain Voltage (NOTE 1)	-40V
Gate-Current	50mA
Total Device Dissipation (Derate 2mW/°C to 175°C)	300mW
Storage Temperature Range	-65°C to +175°C
Lead Temperature (1/16" from case for 10 seconds)	255°C

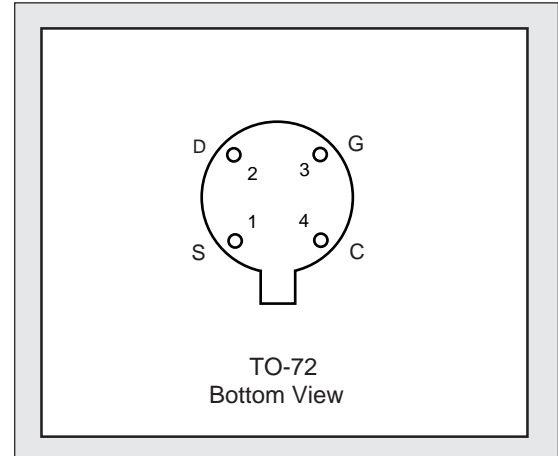

ELECTRICAL CHARACTERISTICS @ 25°C (unless otherwise noted)

SYMBOL	CHARACTERISTICS	2N4117/A FN4117/A		2N4118 2N4118A		2N4119 2N4119A		UNITS	CONDITIONS	
		MIN	MAX	MIN	MAX	MIN	MAX			
I_{GSS}	Gate Reverse Current Standard only	--	-10	--	-10	--	-10	pA	$V_{GS} = -20V$ $V_{DS} = 0$	150°C
		--	-25	--	-25	--	-25	nA		
I_{GSS}	Gate Reverse Current "A" Series only	--	-1	--	-1	--	-1	pA	$V_{GS} = -20V$ $V_{DS} = 0$	150°C
		--	-2.5	--	-2.5	--	-2.5	nA		
BV_{GSS}	Gate-Source Breakdown Voltage	-40	--	-40	--	-40	--	V	$I_G = -1\mu A$ $V_{DS} = 0$	
$V_{GS(off)}$	Gate-Source Cutoff Voltage	-0.6	-1.8	-1	-3	-2	-6		$V_{DS} = 10V$ $I_D = 1nA$	
I_{DSS}	Saturation Drain Current (NOTE 2)	0.03	0.09	0.08	0.24	0.20	0.60	mA	$V_{DS} = 10V$ $V_{GS} = 0$	
		FN4117/A 0.015								
g_{fs}	Common-Source Forward Transconductance (NOTE 2)	70	210	80	250	100	330	μmho	$V_{DS} = 10V$ $V_{GS} = 0$	f=1kHz
g_{os}	Common-Source Output Conductance	--	3	--	5	--	10			
C_{iss}	Common-Source Input Capacitance	--	3	--	3	--	3	pF	$V_{DS} = 10V$ $V_{GS} = 0$	f=1MHz
C_{rss}	Common-Source Reverse Transfer Capacitance	--	1.5	--	1.5	--	1.5			

NOTES:

1. Due to symmetrical geometry, these units may be operated with source and drain leads interchanged.
2. This parameter is measured during a 2 ms interval 100 ms after power is applied. (Not a JEDEC condition.)

Linear Integrated Systems

4042 Clipper Ct., Fremont, CA 94538 TEL: (510) 490-9160 • FAX: (510) 353-0261