



245 MHz Clock Generator and Integrated Buffer for PowerPC™

General Description

The **ICS9178-03** generates all clocks required for high speed PowerPC RISC microprocessor systems. Generating clocks in phase with an external reference frequency allows the **ICS9178-03** to be used as a multiplying zero delay buffer. Three different multiplying factors are externally selectable. These factors can be customized for specific applications. An external frequency can be directly applied to aid system testing. With 2X processor clock speeds up to 245 MHz, PECL outputs are provided. User selectable frequency ratios are available for PCLK/BCLK and PCLK/XCLK. Each pair of clocks outputs have separate supply pins to minimize output jitter and allow them to operate at 5V, 3.3V or custom voltage levels.

Features

- Generates 2 PECL 2x processor, 2 TTL/CMOS 1x processor and 10 selectable bus clocks
- 2XPCLK ranges from 75 MHz to 245 MHz (5V or 5V/3.3V mixed supply) or 60 to 170 MHz (3.3V only)
- Asymmetric duty cycle bus clock for PowerPC
- Bus to processor clock skews less than ± 250 ps
- 2XPCLK to PCLK skew controlled at 300 ± 300 ps
- Selectable reference multiplying factors
- Selectable PCLK/BCLK and PCLK/XCLK ratios
- Separate supplies allow 5V and 3.3V output mix
- 3.0V - 5.5V supply range
- 44-pin PQFP package

Applications

- Ideal for high-speed systems based on PowerPC

Block Diagram

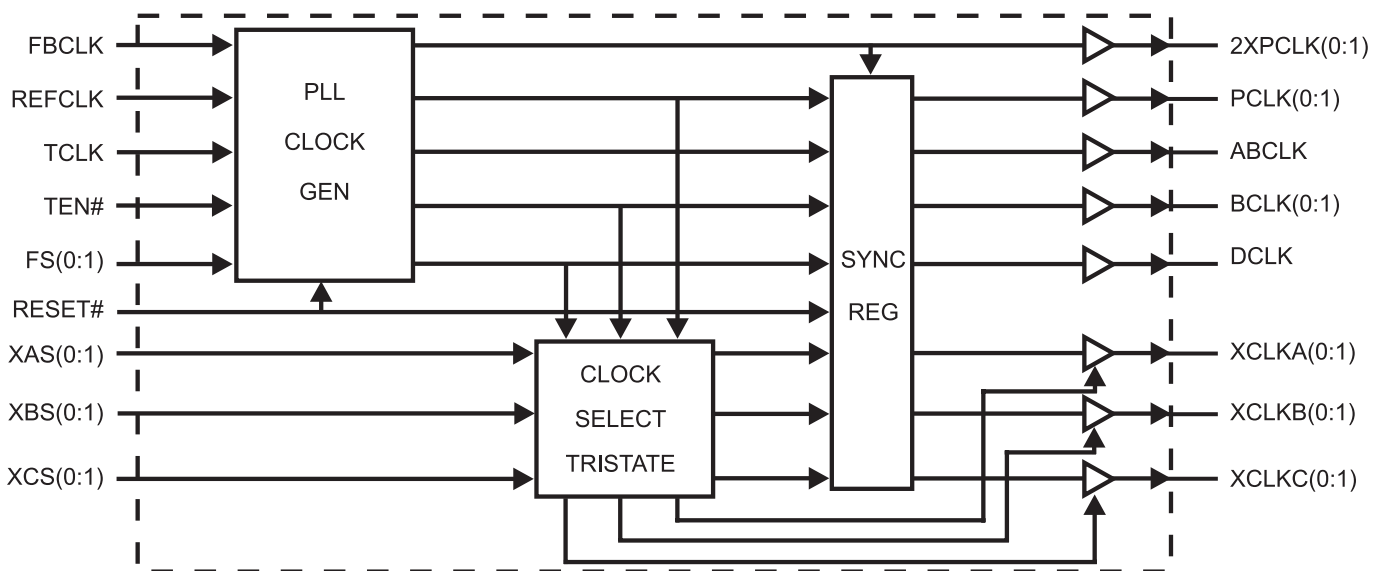

PowerPC is a trademark of Motorola Corporation.



ICS9178-03

Pin Configuration

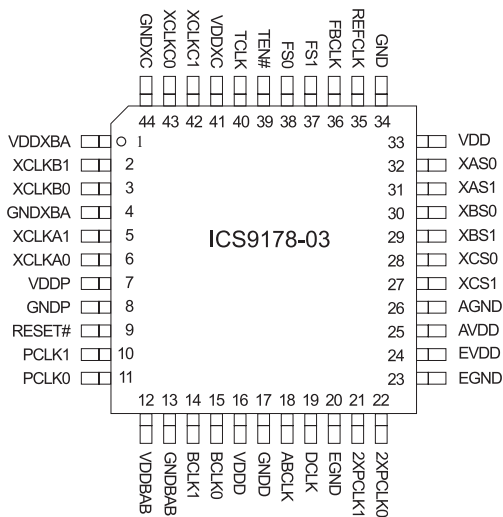

44-Pin PQFP

X_S1	X_S0	XCLK_(0,1)
0	0	PCLK
0	1	BCLK
1	0	DCLK
1	1	Tristate

_ =A,B,C

Functionality

FS1	FS0	RST	TEN	*VCO	2XPCLK	PCLK	ABCLK (H/L%)	BCLK	DCLK
0	0	1	0	6x REF	VCO	VCO/2	VCO/6 (66/33)	VCO/6	VCO/4
0	1	1	0	8x REF	VCO	VCO/2	VCO/8 (75/25)	VCO/8	VCO/4
1	0	1	0	4x REF	VCO	VCO/2	VCO/12 (50/50)	VCO/4	VCO/4
1	1	1	0	X	1	1	1	1	1
X	X	0	X	X	0	0	0	0	0
0	0	1	1	TCLK	TCLK	TCLK/2	TCLK/6 (66/33)	TCLK/6	TCLK/4
0	1	1	1	TCLK	TCLK	TCLK/2	TCLK/8 (75/25)	TCLK/8	TCLK/4
1	0	1	1	TCLK	TCLK	TCLK/2	TCLK/12 (66/33)	TCLK/12	TCLK/4
1	1	1	1	TCLK	TCLK	TCLK/2	TCLK/2	TCLK/2	TCLK/4

*VCO range is limited from 75- 245 MHz at 5V±5% and 60 - 170 MHz at 3.3V±5%. Divide ratios assume BCLK is externally fed back to FBCLK.

The 2XPCLK series or Thevenin trace terminations must be optimized for the specific operating frequency and board layout. The rising edge of ABCLK is coincident with the rising edges of 2XPCLK, PCLK and other BCLKs.



Pin Description

PIN NUMBER	PIN NAME	TYPE	DESCRIPTION
32	XAS0	Input	LSB Programmable Group A frequency selector.
31	XAS1	Input	MSB Programmable Group A frequency selector.
6	XCLKA0	Output	TTL/CMOS group A programmable clock output.
5	XCLKA1	Output	TTL/CMOS group A programmable clock output.
30	XBS0	Input	LSB Programmable Group B frequency selector.
29	XBS1	Input	MSB Programmable Group B frequency selector.
3	XCLKB0	Output	TTL/CMOS Group B programmable clock output.
2	XCLKB1	Output	TTL/CMOS Group B programmable clock output.
1	VDDXBA	—	Power for programmable Group A and B buffers (Pins 2, 3, 5, 6).
4	GNDXBA	—	Ground for programmable Group A and B buffers (Pins 2, 3, 5, 6).
44	GNDXC	—	Ground for the programmable Group C buffers (Pins 42 and 43).
43	XCLKC0	Output	TTL/CMOS Group C programmable clock output.
42	XCLKC1	Output	TTL/CMOS Group C programmable clock output.
41	VDDXC	—	Power for the XC signal output buffers (Pins 42 and 43).
28	XCS0	Input	LSB Programmable Group C frequency selector.
27	XCS1	Input	MSB Programmable Group C frequency selector.
11	PCLK0	Output	TTL/CMOS 1X Processor clock output.
10	PCLK1	Output	TTL/CMOS 1X Processor clock output.
8	GNDP	—	Ground for PCLK output buffers (Pins 11 and 10).
7	VDDP	—	Power for PCLK output buffers (Pins 11 and 10).
22	2XPCLK0	Output	PECL 2X Processor clock output.
21	2XPCLK1	Output	PECL 2X Processor clock output.
24	EVDD	—	Power for PECL buffers (Pins 21 and 22).
23	EGND	—	Ground for PECL buffers (Pins 21 and 22).
20	EGND	—	Ground for PECL buffers (Pins 21 and 22).
38*	FS0	Input	LSB frequency select PLL (divider mode control).
37*	FS1	Input	MSB frequency select PLL (divider mode control).
36	FBCLK	Input	External PLL feedback path from one of the BCLK outputs.
35	REFCLK	Input	External reference clock input.
25	AVDD	—	Power for the analog PLL circuitry.
26	AGND	—	Ground for the analog PLL circuitry.
19	DCLK	Output	TTL/CMOS D clock output.
16	VDDD	—	Power for D output buffers (Pin 19).
17	GNDD	—	Ground for D output buffer (Pin 19).
15	BCLK0	Output	TTL/CMOS B (Bus) clock output.
14	BCLK1	Output	TTL/CMOS B (Bus) clock output.
13	GNDBAB	—	Ground for output buffers AB and B clocks (Pins 14, 15 & 18).
12	VddbAB	—	Power for output buffers AB and B clocks (Pins 14, 15 & 18).
18	ABCLK	Output	TTL/CMOS AB Bus clock (has Asymmetric duty cycle).
40	TCLK	Input	External test clock input.
39	TEN#	Input	Test enable (tie low).
9	RESET#	Input	Sync register reset (active low).
33	VDD	—	Digital power supply for 5.0 or 3.3V.
34	GND	—	Digital ground supply.

*=Pin is pulled-up to VDD internally by the device.



ICS9178-03

Absolute Maximum Ratings

- VDD referenced to GND 7V
- Operating temperature under bias..... 0°C to +70°C
- Storage temperature -65°C to +150°C
- Voltage on I/O pins referenced to GND..... GND -0.5V to VDD +0.5V
- Power dissipation 0.5 Watts

Stresses above those listed under Absolute Maximum Ratings may cause permanent damage to the device. This is a stress rating only and functional operation of the device at these or any other conditions above those indicated in the operational sections of the specifications is not implied. Exposure to absolute maximum rating conditions for extended periods may affect product reliability.

Electrical Characteristics

Device Specifications

Maximum Ratings				
DESCRIPTION	SYMBOL	MIN	MAX	UNITS
Supply voltage relative to GND	VDD	-0.5	7.0	V
Input voltage with respect to GND	VIN	-0.5	VDD +0.5	V
Operating temperature	TOPER	0	+70	°C
Storage temperature	TSTOR	-65	+150	°C
Max soldering temperature (10 sec)	TSOL		+260	°C
Junction temperature	Tj		+135	°C
Package power dissipation	PDISS	800	900	mWatts

DC Characteristics

VDD =+5V ±5%, 0°C ≥ AMBIENT ≥ +70°C unless otherwise stated

PARAMETER	SYMBOL	TEST CONDITIONS	MIN	TYP	MAX	UNITS
High level input voltage	VIH		2.0			V
Low level input voltage	VIL				0.8	V
High level CMOS output voltage	VOH	IOH=-25mA	2.4			V
Low level CMOS output voltage	VOL	IOL=25mA			0.4	V
High level PECL output voltage (2XPCLK) (Note 1)	VOHP	110 ohm load to ground	1.9	2.2		V
Low level PECL output voltage (2XPCLK) (Note 1)	VOLP	110 ohm load to ground		0.3	0.5	V
Input high current	IiH	VIH=VDD	-10		10	µA
Input low current (MSX pins, pull-up)	IiL1	VIL=0V			-150	µA
Input low current (other inputs)	IiL2	VIL=0V	-10		10	µA
Output leakage current (XCLKs)	IoZ	(tristate)	-10		10	µA
Power supply current	IDD	@240 MHz on 2XPCLK		145	185	mA
Power supply current (typical) (Note 1)	IDD-TYP	@75 MHz on 2XPCLK		80	100	mA
Input capacitance (Note 1)	CIN				8	pF

Note 1: Parameter is guaranteed by design and characterization. Not tested 100% in production.



AC Characteristics

V_{DD} = +5V ±5%, 0°C ≥ T_{AMBIENT} ≥ +70°C unless otherwise stated

PARAMETER	SYMBOL	TEST CONDITIONS	MIN	TYP	MAX	UNITS
Input Frequency (Note 1)	f _i		8	40.0	50.0	MHz
Input Clock Rise time (Note 1)	ICLK _r		-	-	3	ns
Input Clock Fall time (Note 1)	ICLK _f		-	-	3	ns
Output Frequency (2XPCLK)	fo2XPCLK	6X mode, 8X mode	75		245	MHz
		4X mode	75		240	
Output Rise time, 0.8 to 2.0V 20% to 80% (Note 1)	tr2XPCLK	15pF load 0.8 to 2.0V	-	-	1.0	ns
		20% to 80%	-	-	1.5	
Fall time 2.0 to 0.8 80% to 20% (Note 1)	tf2XPCLK	15pF load 2.0 to 0.8V	-	-	1.0	ns
		80% to 20%			1.5	
Output Rise time 80% to 20% (Note 1)	t(TTL) _r	15pF load	-	-	3.0	ns
Output Fall time 80% to 20% (Note 1)	t(TTL) _f	15pF load	-	-	2.0	ns
Duty cycle 2XPCLK (Note 1)	dt1	200 to 240 MHz @ 1.4V 110 ohm, 15pF load	42.5	50	57.5	%
Pulse Width, High, 2XPCLK (Note 1, 2)	T _{pwr}	@ 1.8V, 110ΩLoad 2	1.2	-	-	ns
Pulse Width, Low, 2XPCLK (Note 1, 2)	T _{pwr}	@ 0.6V, 110ΩLoad 2	1.0	-	-	ns
Duty cycle ABCLK (Note 1)	dt3	15pF load @ 1.4V (8X mode)	70	75	80	%
Duty cycle ABCLK (Note 1)	dt4	15pF load @ 1.4V 6X mode	61	66	71	%
		15pF load @ 1.4V 4X mode	45	50	55	
Duty cycle TTL (other clocks) (Note 1)	dt5	15pF load @ 1.4V	45	50	55	%
Jitter 1 Sigma 2XPCLK (10,000 samples) (Note 1)	T _{j1s1}	for 200 to 240 MHz on 2XPCLK	-	40	-	ps
Jitter 1 Sigma 1XPCLK B & D (10,000 samples) (Note 1)	T _{j1s2}	for 200 to 240 MHz on 2XPCLK	-	50	-	ps
Jitter 1 Sigma AB clock (10,000 samples) (Note 1)	T _{j1s3}	for 200 to 240 MHz on 2XPCLK	-	60	-	ps
Jitter Absolute 2XPCLK (Note 1)	T _{jabs1}	for 200 to 240 MHz on 2XPCLK	-150	80	+150	ps
Jitter Absolute 1XPCLK, B, D clocks (Note 1)	T _{jabs2}	for 200 to 240 MHz on 2XPCLK	-200	110	+200	ps
Jitter Absolute AB clock (Note 1)	T _{jabs3}	for 200 to 240 MHz on 2XPCLK	-250	120	+250	ps

Note 1: Parameter is guaranteed by design and characterization. Not tested 100% in production.

Note 2: For 70Ω Load, 2XPCLK level may be pulled-up with a 390Ω resistor to meet minimum pulse width requirements at both 1.8V and 0.6V at 240 MHz.



ICS9178-03

AC Characteristics (continued)

V_{DD} = +5V ±5%, 0°C ≤ T_{AMBIENT} ≤ +70°C unless otherwise stated

PARAMETER	SYMBOL	TEST CONDITIONS	MIN	TYP	MAX	UNITS
Jitter Absolute 2XPCLK (Note 1)	T _{jabs4}	for 200 to 240 MHz on 2XPCLK at VDD 4.9 to 5.2V	-125	80	+125	ps
Jitter Absolute 1XPCLK, B, D clocks (Note 1)	T _{jabs5}	for 200 to 240 MHz on 2XPCLK at VDD 4.9 to 5.2V	-160	110	+160	ps
Jitter Absolute 2XPCLK (Note 1)	T _{jabs6}	for < 200 MHz on 2XPCLK	-200	-	+200	ps
Jitter Absolute 1XPCLK (Note 1)	T _{jabs7}	for < 200 MHz on 2XPCLK	-250	-	+250	ps
Jitter Absolute AB clock (Note 1)	T _{jabs8}	for < 200 MHz on 2XPCLK	-300	-	+300	ps
Skew, output to output (P, B, D, AB abd XCLKs) (Note 1)	T _{skew1}	@ 1.4V	-250	-	+250	ps
Skew, 2XPCLK to PCLK (2XPCLK is earlier than PCLK) (Note 1)	T _{skew2}	@ 1.4V	-600	-300	0	ps
Skew, 2XPCLK to REFCLK (2XPCLK is earlier) (Note 1)	T _{skew3}	for 240 MHz on 2XPCLK @ 1.4V	-600	-300	0	ps
Skew, 2XPCLK to DCLK (Notes 1,3)	T _{skew4}	@ 1.4V	-600	-100	100	ps

Note 1: Parameter is guaranteed by design and characterization. Not tested 100% in production.

Note 2: For 70Ω Load, 2XPCLK level may be pulled-up with a 390Ω resistor to meet minimum pulse width requirements at both 1.8V and 0.6V at 240 Mhz.

Note 3: 2XPCLK is normally earlier than DCLK by up to 600ps and can be later by up to



ICS9178-03

Applications

PwrPC 601/601+Processor Modules

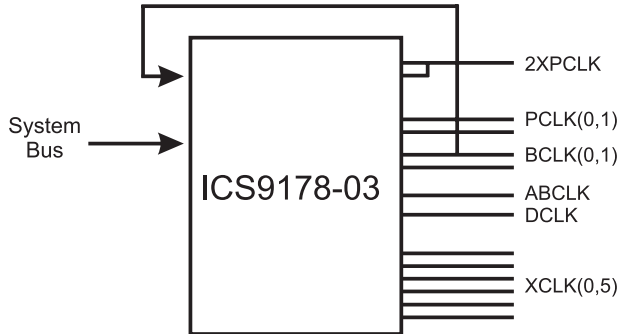

PwrPC 601\601+ System Clock Diagram

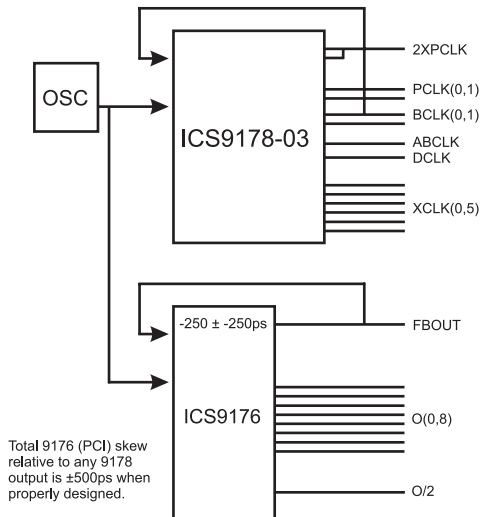

PwrPC 603/604 System Clock Diagram

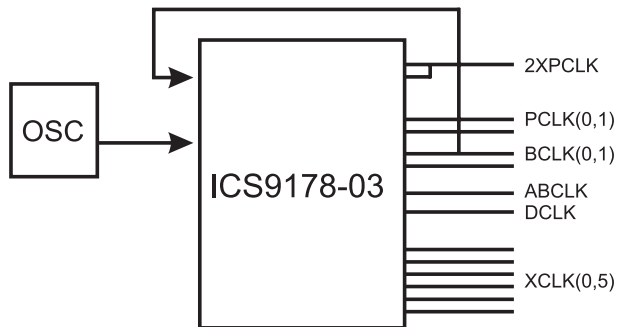

Provides 2 Processors, 4 Local Bus, and 6 PCI/VL Bus Clocks

Frequency Combinations

(XCLK pairs selectable)

SYS BUS	9178 MODE	2XPCLK (2XCPU)	PCLK(0,1) (CPU)	XCLK(0,5) (BUS)	BCLK(0,1) ABCLK
F	x4	4F	2F	2F, 1F	1F
F	x6	6F	3F	3F, 1.5F, 1F	1.5F
F	8F	8F	4F	4F, 2F, 1F	2F

Frequency Combinations

(selectable SCLK)

OSC	9178 MODE	2XPCLK (2XCPU)	PCLK (CPU)	XCLK (BUS)	Q (PCI)
F	x4	4F	2F	2F, 1F	1F
F	x6	6F	3F	3F, 1.5F, 1F	1.5F
F	8F	8F	4F	4F, 2F, 1F	2F
33	x4	132	66	66, 33	33
33	x6	196	99	99, 48, 33	33
33	x8	264	132	132, 66, 33	33
30	x4	120	60	60, 30	30
30	x6	180	90	90, 45, 30	30
30	x8	240	120	120, 60, 30	30
25	x4	100	50	50, 25	25
25	x6	150	75	75, 37, 25	25
25	x8	200	100	100, 50, 25	25

Frequency Combinations

(9178 x4 mode)

OSC	PwrPC MODE	PCLK, DCLK (CPU)	PwrPC INTERNAL CLOCK	PCLK(0,1) XCLK(0,3) (BUS)	ABCLK, BCLK(0,1) XCLK(4,5)
F	-	2F, 1F	-	2F, 1F	F
33	x1, x2	66, 33	66	66, 33	33 (PCI)
40	x1, x2	80, 40	80	80, 40	40 (VL)
33	x3	-, 33	100	66, 33	33 (PCI)
30	x2, x4	60, 30	120	60, 30	30 (PCI)
40	x3	-, 40	120	80, 40	40 (VL)
33	x2, x4	66, 33	132	66, 33	33 (PCI)



ICS9178-03

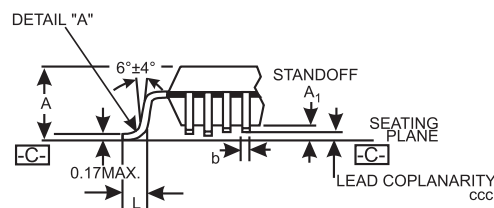
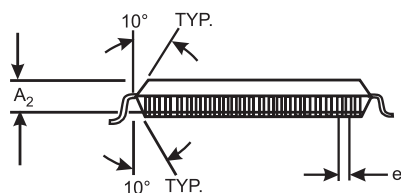
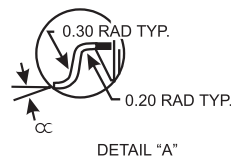
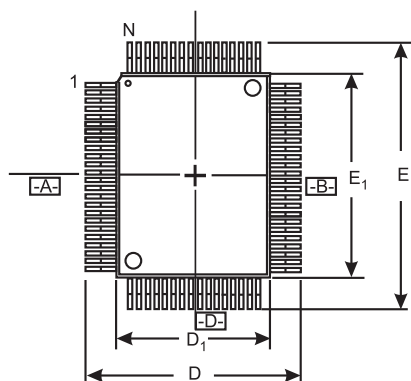

PQFP Package

LEAD COUNT		44L
BODY THICKNESS		2.0
FOOTPRINT (BODY+)		3.20
DIMENSIONS	TOLERANCE	
A	MAX.	2.45
A1	MAX.	0.25
A2	±0.10	2.00
D	±0.25	13.20
D1	±0.10	10.0
E	±0.25	13.20
E1	±0.10	10.0
L	±0.15/-0.10	0.70
e	BASIC	0.80
b	+0.05	0.35
ccc	MAX.	0.10
∞		0° - 7°

Ordering Information ICS9178Y-03

Example:

ICS XXXX- M PPP

