

REV.	DESCRIPTION	DRAWN	CHECKED	APPROVED
A	NEW RELEASE	LL 07/02/06'		

NOTES:

- ELECTRICAL CHARACTERISTICS:
 - CONTACT RESISTANCE: 20mΩ Max.
 - DIELECTRIC WITHSTANDING VOLTAGE: 500V AC(rms) FOR 1 MINUTE.
 - INSULATION RESISTANCE: 1000MΩ Min.
- ENVIRONMENT CHARACTERISTICS:
 - OPERATING TEMPERATURE: 0°C~+85°C.
 - STORAGE TEMPERATURE: -20°C~+70°C.
- PRODUCT NUMBER CODE:
DS1002-01 - X X X X

Clip plating

- Tin 150u"
- Tin 200u"
- G/F
- Gold 3u"
- Gold 10u"
- Gold 15u"

Pin plating

- Tin 150u"
- Tin 200u"
- G/F
- Gold 3u"
- Gold 10u"
- Gold 15u"

Mounting type

- V: V/T TYPE
R: R/A TYPE
S: SMT TYPE

No. of contacts

- 1*1 - 1*64
2*1 - 2*40

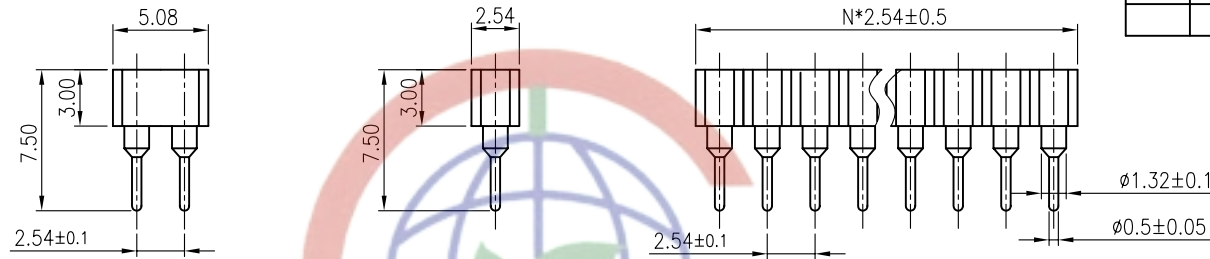

Dual rows

Single row

V/T TYPE

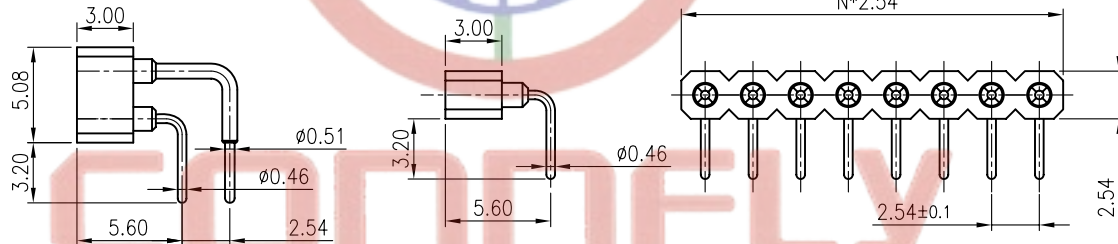

Dual rows

Single row

R/A TYPE

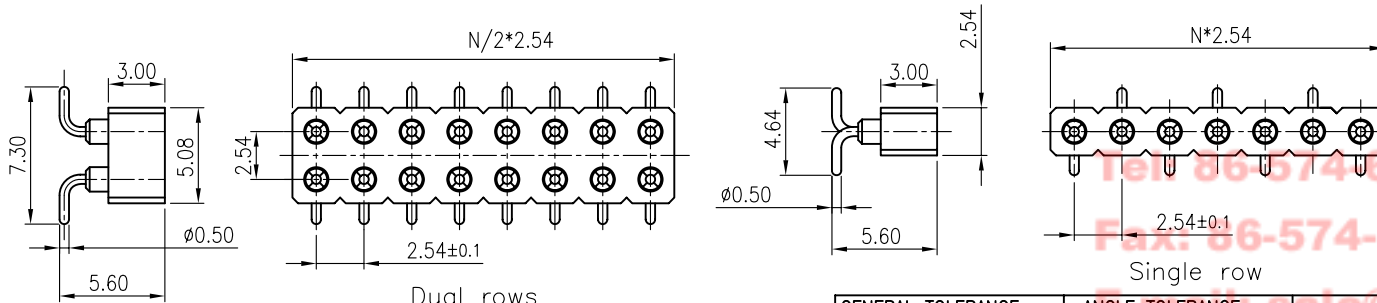

Dual rows

Single row

SMT TYPE

N: No. of contacts

GENERAL TOLERANCE		ANGLE TOLERANCE		PROJECTION	TITLE
X.	±0.60	X.	±5°	mm	IC SOCKET R/A & V/T & SMT
.X	±0.38	.X	±3°		PITCH 2.54mm
.XX	±0.25	.XX	±2°		SERIES DS1002-01 SERIES
DRAWING TYPE	CUSTOMER	SHEET SIZE A4			
SCALE	1:1	SHEET 10F1			
DRAWING NO.	C-DS1002-01-XXXX	DRAWING NO.			

晨翔电子有限公司
CONNFLY CONNFLY ELECTRONIC CO. LTD